

A10, D10 and D10 Turbo Theft-resistant
cage parts identification

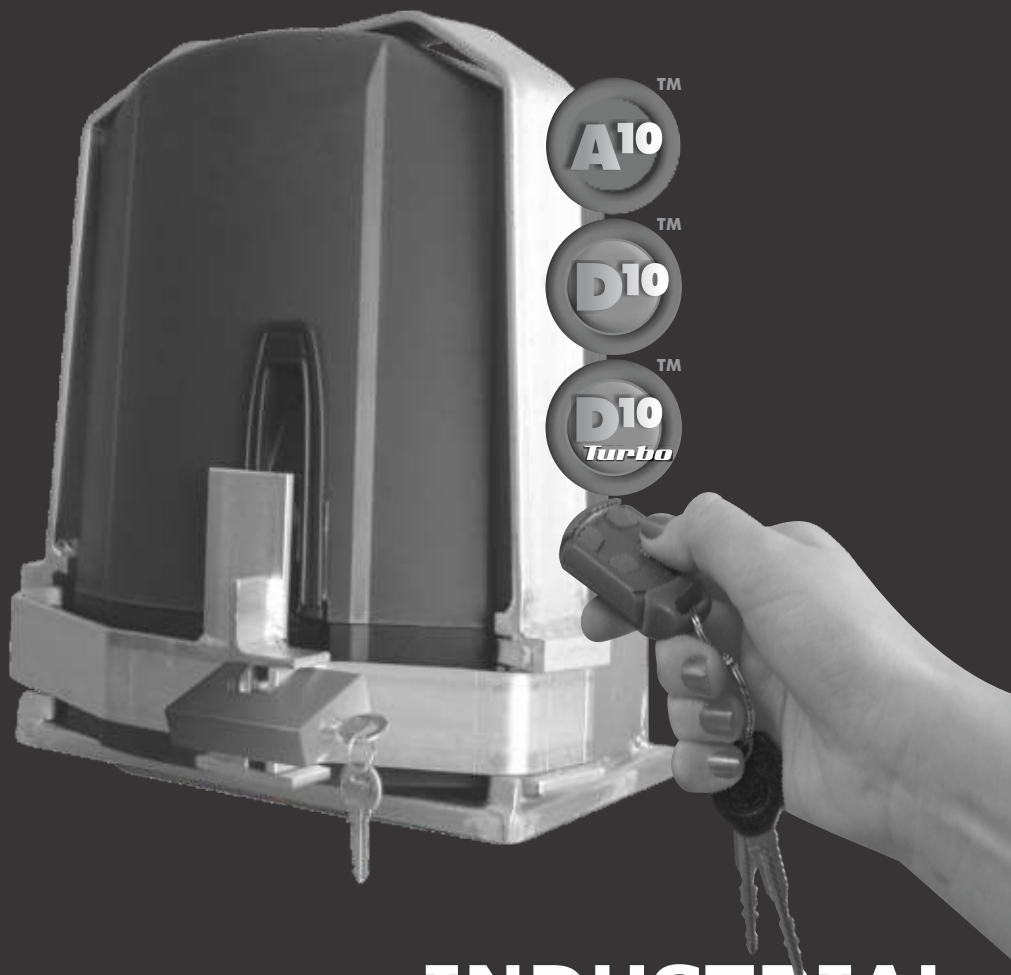

CENTURION



**INDUSTRIAL
SLIDING
GATE
OPERATORS**

1. General description

The CENTURION **A10/D10/D10 Turbo Theft-resistant Cages** are designed to significantly reduce the risk of an intruder gaining access to the operator's Manual Release, and increases the resistance of the unit against theft. Manufactured from 304 brushed stainless steel, it will not only enhance the security of your entrance, but will add to the aesthetic appeal too.

It is important that the **Theft-resistant Cage** is properly fitted as per the instructions given and that a suitable lock is fitted. Please note that a lock is not supplied in this kit. CENTURION recommends using a discus-type lock.

Disclaimer: Centurion Systems (Pty) Ltd cannot be held liable under any circumstances for any damage, loss or action that results from the **A10/D10/D10 Turbo Theft-resistant Cage** being forced open or tampered with.

2. Product identification

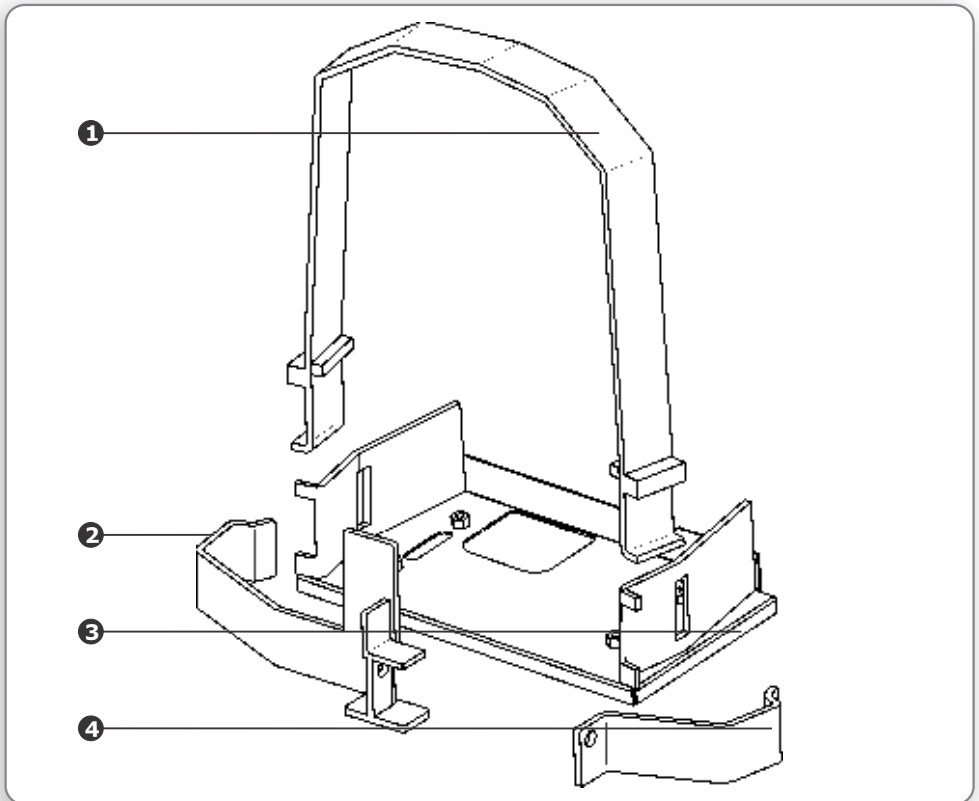

1. Overstrap

2. Left hand front strap

3. Base plate

4. Right hand front strap



3. Step-by-step installation instructions

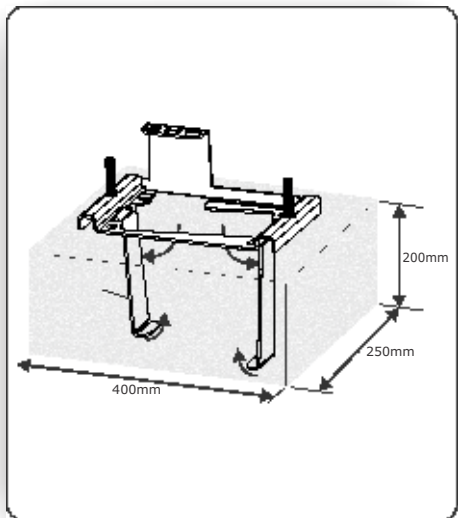

1. Ensure that the foundation plate has been properly installed. Refer to the Installation Manual for details.

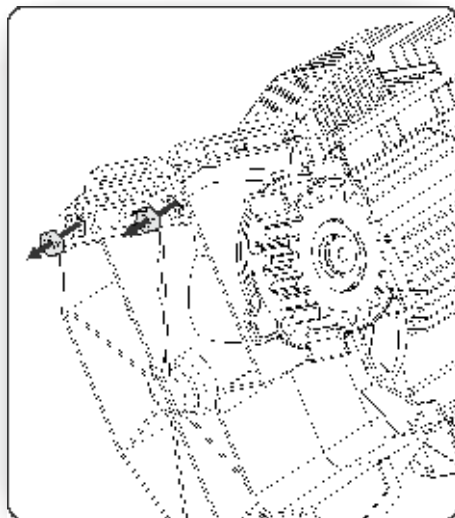

2. Remove all four captive nuts from the underside of the gearbox as shown. These are no longer required, as the threaded holes in the cage baseplate serve for height adjustment.

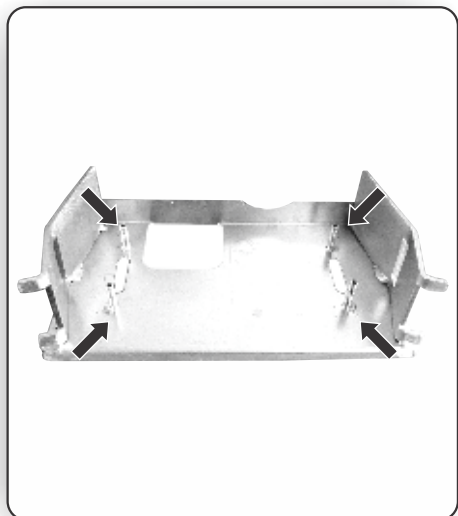

3. Screw the four M8x40 socket head grub screws supplied with A10/D10/D10 Turbo into the threaded holes in the base plate.

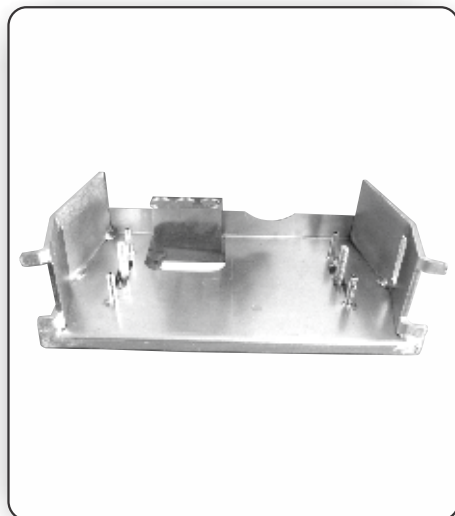

4. Place the base plate over the foundation plate.

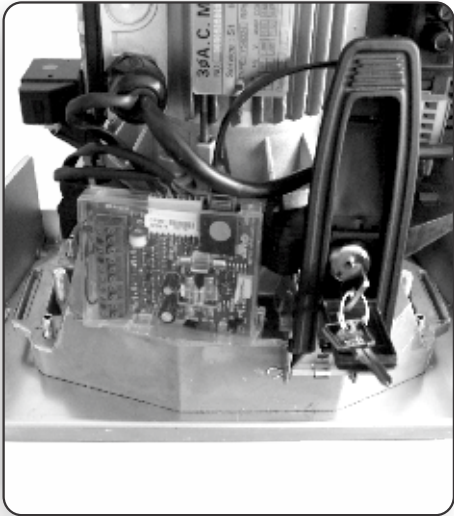

5. Place the gate motor over the base plate, making sure that the four grub screws and two mounting bolts from the foundation plate fit through the gate motor as shown.

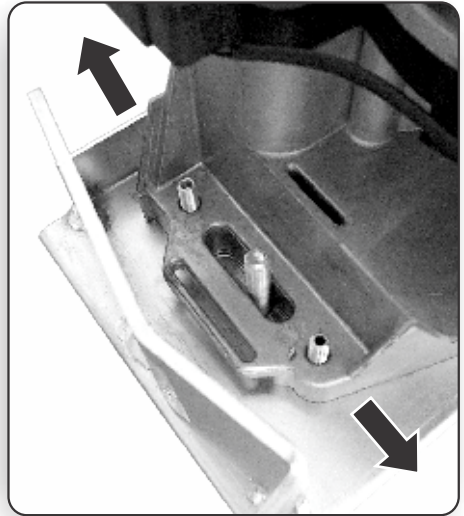

6. Slide the gate motor forward or backward so that the pinion will correctly engage with the rack.

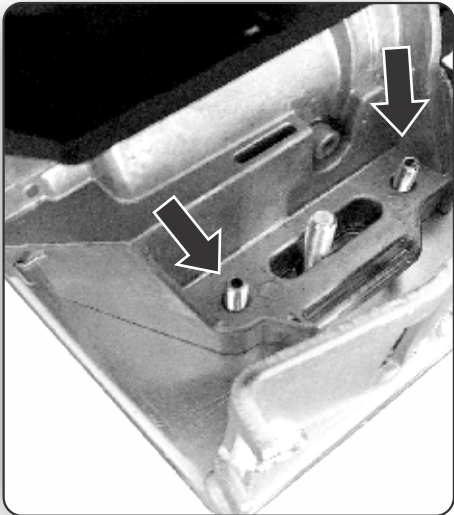

7. Adjust the height of the gate motor by tightening the four socket head grub screws equally; making sure the gate motor is level once complete.

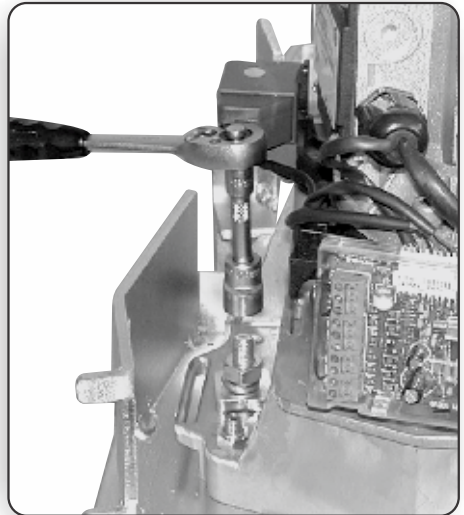

8. Assemble nut, spring washer, and load spreader onto the mounting bolts.

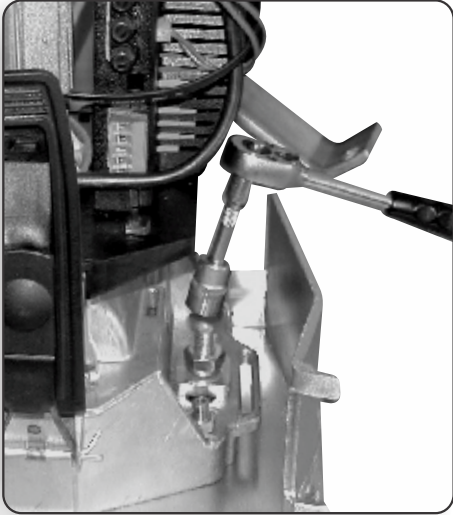

9. Tighten nuts progressively i.e. left hand, then right hand, then left hand. Do not over tighten nuts.

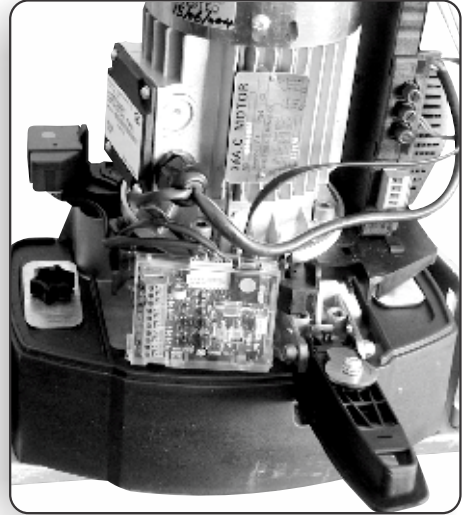

10. Replace the lower gear box cover.



11. Replace the main gear box cover.



12. Fit the over strap over the gate motor. The over strap will only fit one way.



13. Assemble the left hand and right hand side straps to the base plate.

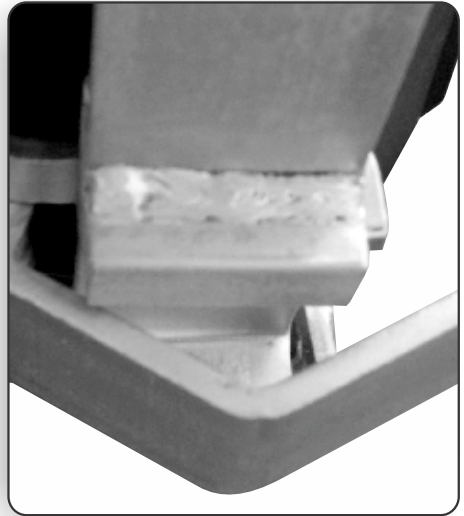

14. Hook the left hand side strap into the vertical slot provided in the left side of the base plate.



15. Hook the right hand side strap into the vertical slot provided in the right side of the base plate.

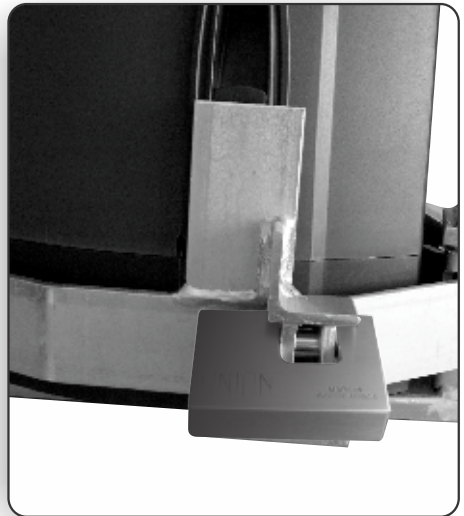

16. Finally, secure the cage by locking the left and right hand side straps together. A padlock with a 13mm diameter pin and 25mm 'throat' is recommended, (often referred to as a '78mm' lock).



Sharecall 0860-CENTURION (0860 236 887)
Head Office: +27 11 699 2400

Sharecall Technical Support 0861 003 123 or
+27 11 699 2481
from 07h00 to 18h00 (GMT+2)

(Sharecall numbers applicable when dialed from within South Africa only)



0.07.A.0010

www.centsys.com