

VECTOR2, VANTAGE & VERT-X User Guide

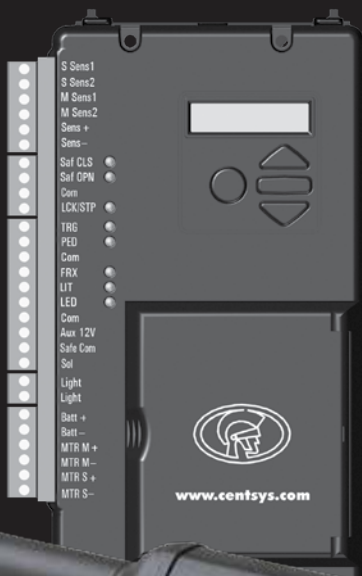

LINEAR SWING GATE MOTORS

Company Profile



1986



1990



1995



1999



Today

In-house R&D development team



Manufacture to international quality standard ISO 9001:2008



100% testing of products

After-sales multi-language Technical Support from 07h00 to 18h00 UTC+2 Monday to Friday



Sales and technical support to Africa, Europe, Asia, the Americas, Australia and the Pacific

Centurion Systems (Pty) Ltd reserves the right to make changes to the products described in this manual without notice and without obligation of Centurion Systems (Pty) Ltd to notify any persons of any such revisions or changes. Additionally, Centurion Systems (Pty) Ltd makes no representations or warranties with respect to this manual. No part of this document may be copied, stored in a retrieval system or transmitted in any form or by any means electronic, mechanical, optical or photographic, without the express prior written consent of Centurion Systems (Pty) Ltd.



Contents

**SAFETY
FIRST**
IMPORTANT SAFETY INSTRUCTIONS

page 6

Introduction	page 8
V-Series Overview	page 9
1. V-Series Parts Identification	page 10
2. V-Series Manual Override	page 14
2.1. Disengaging the Operator	page 14
3. Features and Functions	page 16
3.1. Introduction	page 16
3.2. Gate Operation	page 16
3.2.1. Full Gate Opening	page 16
3.2.2. Modes of Operation	page 17
3.2.2.1. Standard Mode	page 17
3.2.2.2. Reverse Mode	page 17
3.2.2.3. Condominium Mode	page 18
3.2.3. Autoclose Mode	page 18
3.2.3.1. Autoclose Override	page 19
3.2.3.2. Autoclose Advanced Options	page 20
3.2.4. Pedestrian Opening	page 20
3.2.5. Free-exit Opening	page 22
3.2.6. PIRAC Mode (Beam Autoclose Mode)	page 23
3.2.6.1. PIRAC Override	page 24
3.2.7. Holiday Lockout Mode	page 24
3.2.8. Positive Close Mode	page 25
3.2.9. Positive Open Mode	page 26
3.2.10. Motor Run Profiles	page 26
3.3. Gate Lock	page 26
3.4. Anti-crushing Sensitivity	page 27
3.4.1. Collision Count	page 28

3.5. Infrared Safety Beams (optional but recommended)	page 28
3.5.1. Closing Safety Beams	page 28
3.5.2. Opening Safety Beams	page 28
3.6. Intruder-detection Alarms (optional but recommended)	page 29
3.6.1. Ambush Alarm	page 29
3.6.2. Break-in Alarm	page 29
3.7. External Gate Status Indication	page 30
3.8. Courtesy (Pillar) Light Timer	page 31
3.8.1. Courtesy (Pillar) Light Control	page 31
3.8.2. Courtesy (Pillar) Lights act as Warning Light	page 32
3.8.3. Pre-open and Pre-close Delays	page 32
3.9. Onboard Multichannel Receiver	page 32
3.10. Battery-Low Protection	page 33
4. Additional Features	page 34
4.1. Solar Power Supply	page 34
4.2. Lightning Protection	page 34
4.3. Leaf Delay	page 34
5. Basic Maintenance	page 36
5.1. General	page 36
5.2. Battery	page 36
5.3. Charger	page 37
6. Diagnostics	page 38
7. Troubleshooting Guide	page 39
8. Technical Specifications	page 44
8.1. VECTOR2 Specifications	page 44
8.2. VANTAGE Specifications	page 45
8.3. VERT-X Specifications	page 46
9. 24 Month Carry-in Product Warranty	page 47
10. Optional Extras	page 48

Icons Used in this Manual



This icon indicates tips and other information that could be useful during the installation.



This icon denotes variations and other aspects that should be considered during installation.



This icon indicates warning, caution or attention! Please take special note of critical aspects that MUST be adhered to in order to prevent injury.

IMPORTANT SAFETY INSTRUCTIONS

ATTENTION

To ensure the safety of people and possessions, it is important that you read all the following instructions.

Incorrect installation or incorrect use of the product could cause serious harm to people.



The installer, being either professional or DIY, is the last person on the site who can ensure that the motor is safely installed, and that the whole system can be operated safely.

Warnings for the Installer

CAREFULLY READ AND FOLLOW ALL INSTRUCTIONS before beginning to install the product.

- All **installation, repair, and service work** to this product must be done by a **suitably qualified person**
- Safety devices such as infrared gate safety beams must be fitted to the installation to prevent the gate from moving should anything be in the path of the gate. The mechanical movement of the gate presents risks such as crushing, dragging and shearing
- It is recommended that at least one **warning indicator light** be fitted to every system
- Always **fit the warning signs** visibly to the inside and outside of the gate
- Do not activate your gate motor unless you can see it and can determine that its area of travel is clear of people, pets, or other obstructions
- If a **pedestrian** gate opening device, such as a keypad, has been fitted it is recommended to always **have a Pre-Opening Delay activated** when operating the Pedestrian Opening. This will allow a pedestrian sufficient time to ensure that he/she is well clear of the gate before it begins to move. Pedestrian gate **opening devices should always be installed on the opposite end** of the gate to where the gate motor is located to ensure that the gate opens away from where the pedestrian is standing
- **NO ONE MAY CROSS THE PATH OF A MOVING GATE.** Always keep people and objects away from the gate and its area of travel
- This appliance is not intended for use by persons (including children) **with reduced physical, sensory or mental capabilities**, or lack of experience and knowledge, unless they have been given supervision or instruction concerning use of the gate motor and/or accessories by a person responsible for their safety
- **Children should be supervised to ensure that they do not play with the gate or motor**

- Do not in any way modify the components of the automated system
- Do not install the equipment in an explosive atmosphere: the presence of flammable gas or fumes is a serious source of danger and may compromise safety
- Before attempting any work on the system, **isolate electrical power and disconnect the batteries**
- The mains power supply of the automated system must be fitted with an all-pole switch, mounted within one metre of the motor, with a contact opening distance of 3mm or greater. The use of a 5A hydraulic breaker with all-pole circuit break is recommended
- Make sure that an earth leakage circuit breaker with a threshold of 30mA is fitted upstream of the system
- Never short-circuit the battery and do not try to recharge the batteries with power supply units other than that supplied with the product, or supplied by Centurion Systems (Pty) Ltd and specified for this system
- Make sure that the earthing system is correctly constructed, and that all metal parts of the system are suitably earthed
- **The installer must explain and demonstrate the Manual Override operation** of the gate in case of an emergency, and must hand **over** all Installation Documentation, User Guides and any Safety/Warning Documents provided with the motor to the end-user
- Explain these safety instructions to all persons authorised to use this gate automation system, and be sure that they understand the hazards associated with automated gates
- Do not leave packing materials (plastic, polystyrene, etc.) within reach of children as such materials are potential sources of danger
- Dispose of all waste products like packing materials, worn-out batteries, etc., according to local regulations
- Always **check the obstruction detection system, and/or safety devices for correct operation** prior to hand-over. During the hand-over of the system, explain to the end-user how to perform these checks to confirm that all safety devices are operating correctly
- Neither Centurion Systems (Pty) Ltd, nor its subsidiary companies, accepts any liability for damage caused by improper installation or use of the product, or for use other than that for which the automated system was intended
- This product was designed and built strictly for the use indicated in the documentation provided with the product; any other use, not expressly indicated within the documentation, could be a source of danger and/or compromise the service life/operation of the product and invalidate the warranty
- Anything not expressly specified in these instructions is not permitted

Introduction

This User Guide contains all the information you need to configure and operate your new **V-Series** swing gate motors. From safety instructions to basic principles of operation and an in-depth description of your product's many features and functions. By the time you have finished reading this guide you will have learnt how to make the most out of your **V-Series** gate motors. Even basic maintenance is covered, but in the unlikely event that your product malfunctions, rather leave it to the professionals and contact your installer or nearest Centurion Systems (Pty) Ltd Branch (contact details listed on the back page) for prompt assistance.

V-Series Overview

VERT-X Overview

The **VERT-X** linear swing gate motor has been designed to safely and cost-effectively automate domestic swing gates.

Combining a robust and reliable open-nut drive system with a stainless steel drive shaft, advanced diagnostic capabilities and functionality, rugged die-cast aluminium construction and exceptional aesthetics for a wholly unobtrusive installation, **VERT-X** is positioned firmly at the apex of swing gate automation. In addition, the engineering team behind its design has invested considerable effort into ensuring that the motor is as easy to install as it is powerful, and as reliable as it is good-looking.

VANTAGE Overview

The **VANTAGE** linear swing gate motor, available in two models with actuation strokes of 400mm and 500mm, respectively, has been designed to automate a wide variety of swing gates, from single light-domestic gates to heavy industrial double swing gates.

The fail-safe and fully redundant Position and Collision Detection System has been designed and tested to set the standard in safety of operation and to provide an unparalleled level of reliability and durability in operation.

The gate Travel Limits are managed by a sealed double-redundant opto-electronic system that has been designed to not only ensure ultra-reliable operation, but also to ensure precise position and trajectory control. This enables very accurate and reliable collision detection to ensure safe operation even under trying conditions.

VECTOR2 Overview

The **VECTOR2** linear swing gate motor's linear operating principle with internal position control makes the system quick and easy to install. The revolutionary mechanical design ensures a swift, powerful and reliable motor for the majority of domestic and light-industrial gates.

Two models are available, the V400 and the V500, which have actuation strokes of 400mm and 500mm, respectively. The motor with the longer stroke will run the gate more slowly; however, it will be able to handle a gate which is wider and/or heavier.



The release pins of the **VERT-X**, **VANTAGE** and **VECTOR2** can be fitted with padlocks where additional security is required.

1. V-Series Identification

Refer to the drawings below, on how to identify your **V-Series** motors and their parts.

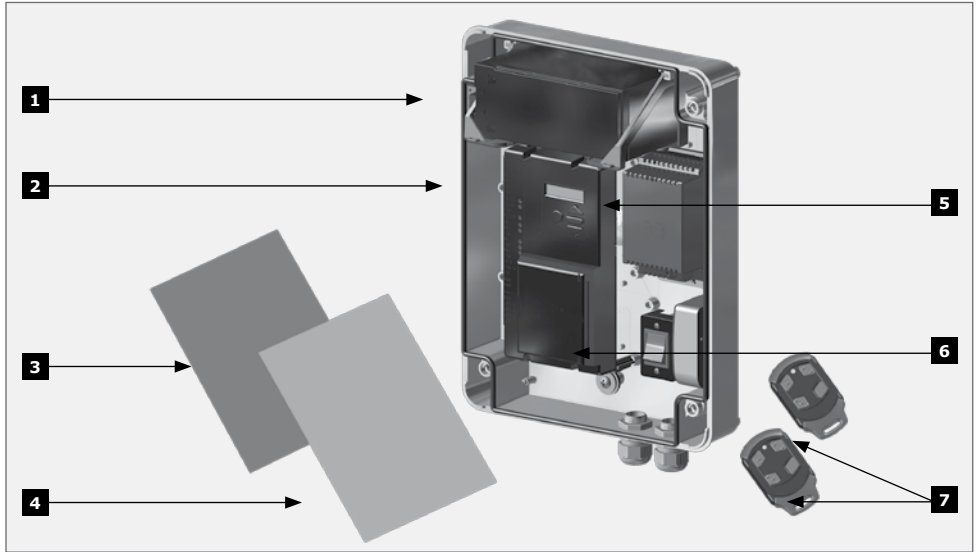

FIGURE 1. V-SERIES WALL BOX INCLUDING CHARGER AND CONTROLLER

- | | |
|---|--|
| 1. 12V 7.2Ah Battery ¹ | 5. Charger |
| 2. V-Series Controller with built-in multichannel receiver | 6. Mains isolator |
| 3. V-Series User Guide | 7. Code-hopping multichannel remote controls |
| 4. V-Series Electrical Setup & Commissioning Guide | |
| 1. Keys are specific to each motor - key number must be recorded | |

1.1. VECTOR2 Swing Gate Motor

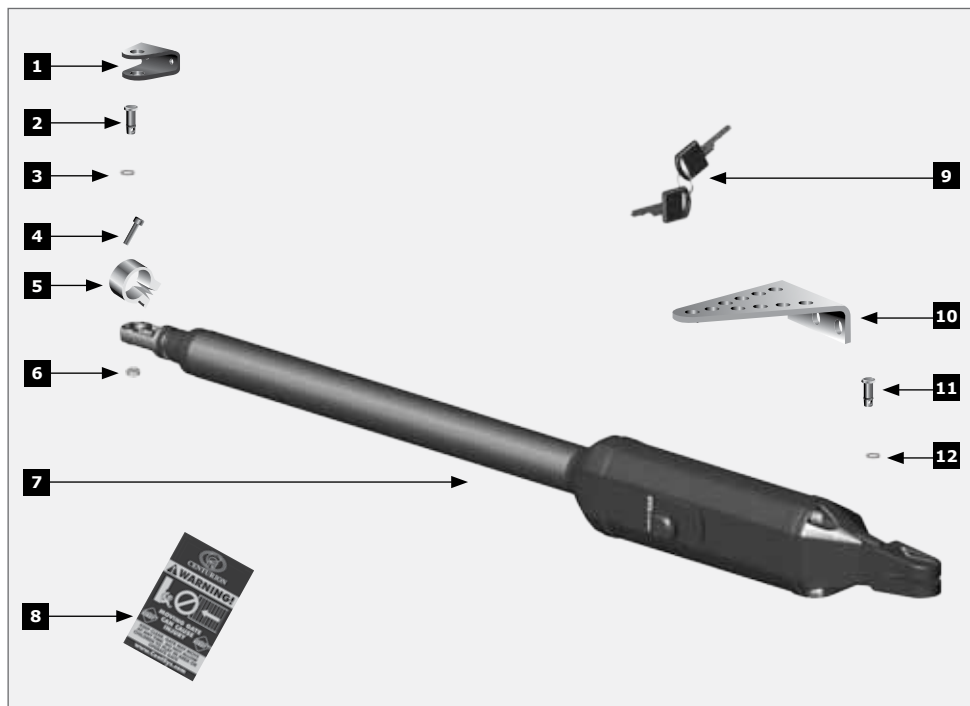

FIGURE 2. VECTOR2 SWING GATE MOTOR

1. Gate Bracket
 2. Gate Bracket pin
 3. 14mm snap ring
 4. Cap screw
 5. Origin Bracket
 6. Nut
 7. **VECTOR2** swing gate motor
 8. Gate warning decal
 9. Gate motor keys ¹
 10. Standard Wall Bracket
 11. Wall Bracket pin
1. Keys are specific to each motor - key number must be recorded

1.2. VANTAGE Swing Gate Motor

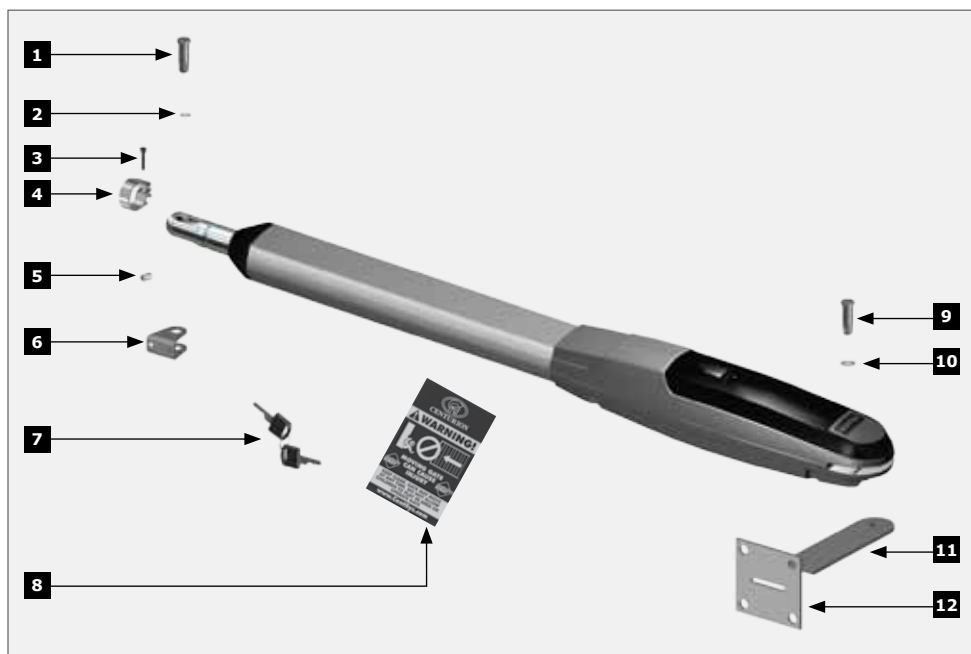

FIGURE 3. VANTAGE SWING GATE MOTOR

- | | |
|--------------------------------------|-------------------------------------|
| 1. Gate Bracket pin | 7. Gate motor keys ¹ |
| 2. 14mm snap ring | 8. Gate warning decal |
| 3. Stainless steel cap screw M5 x 25 | 9. Wall Bracket pin |
| 4. Origin clamp | 10. VANTAGE swing gate motor |
| 5. M5 barrel nut | 11. Wall Bracket |
| 6. Gate Bracket | 12. Wall Bracket mounting plate |
1. Keys are specific to each motor - key number must be recorded

1.3. VERT-X Swing Gate Motor

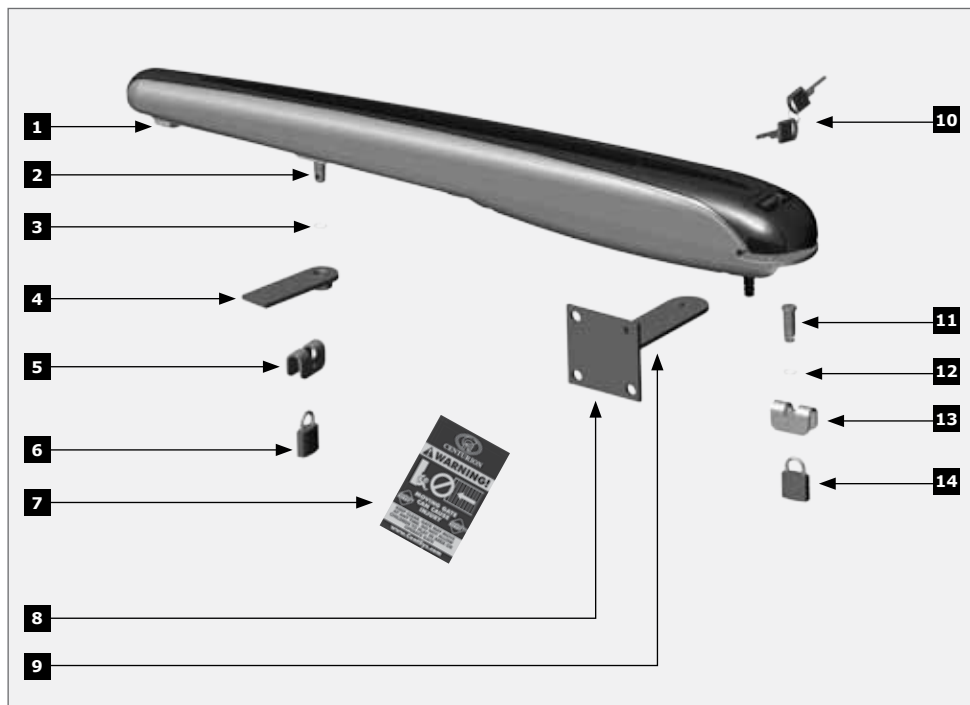

FIGURE 4. VECTOR2 SWING GATE MOTOR

1. **VERT-X** swing gate motor
 2. Gate Bracket pin
 3. 14mm snap rings
 4. Gate Bracket
 5. Padlock shield
 6. Padlock
 7. Gate warning decal
 8. Wall Bracket mounting plate
 9. Wall bracket
 10. Gate motor keys ¹
 11. Wall bracket pin
1. Keys are specific to each motor - key number must be recorded

2. V-Series Manual Override

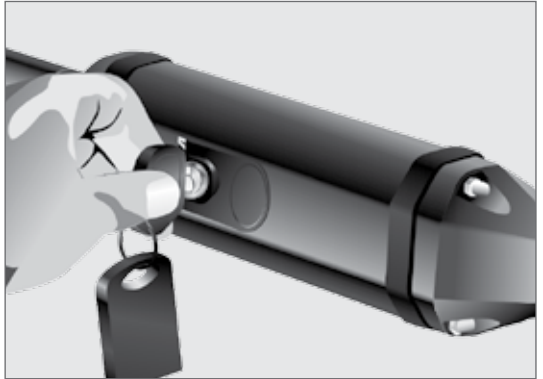

FIGURE 5. VECTOR2 SWING GATE MOTOR

2.1. Disengaging the motor

The **V-Series** motors can be manually released, by turning a removable key through 180° in the Camlock mounted on the main housing of the motor.

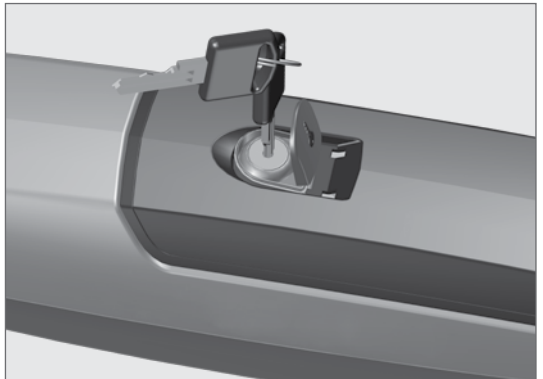

FIGURE 6. VANTAGE SWING GATE MOTOR

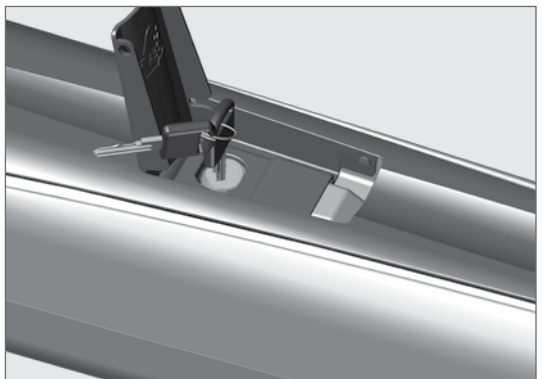

FIGURE 7. VERT-X SWING GATE MOTOR

Fit the key into the Camlock and rotate through 180°.

The motor is now in the override condition and the gate can be pushed open manually.

Close the Camlock Cover after removing the key to reduce the ingress of dirt into the lock mechanism.

Please record the number of the keys as with this number, replacement keys can be cut at most locksmiths (applicable in the Republic of South Africa only).



The Manual Release keys MUST be kept in a safe place as they are unique to the motor and, if lost, will require the motor to be sent to an authorised service centre to have the lock replaced.



FIGURE 8. VECTOR2 SWING GATE MOTOR

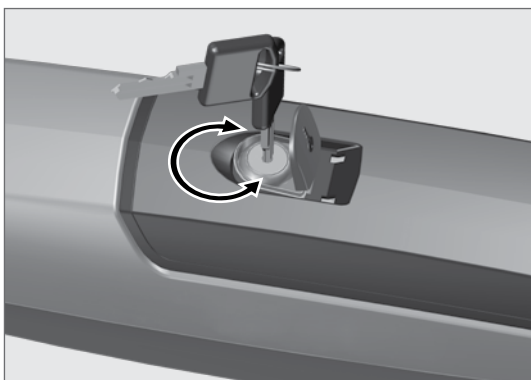

FIGURE 9. VANTAGE SWING GATE MOTOR

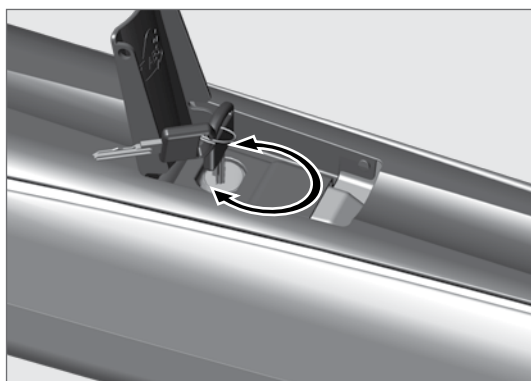



FIGURE 10. VERT-X SWING GATE MOTOR

3. Features and Functions

3.1. Introduction

The **VECTOR2**, **VERT-X** and **VANTAGE** linear swing gate motors are controlled with the **V-Series Controller** (PCA10501Vx). The Controller determines the functions of the gate motor.

The **V-Series Controller** is particularly user-friendly as it is fitted with an LCD (Liquid Crystal Display) that provides useful information on the status of the system.

 Under normal running conditions the 'User Display' is shown on the LCD display. (A 'Debug Display' can be invoked and is typically used by the installer where abnormal operational problems occur).

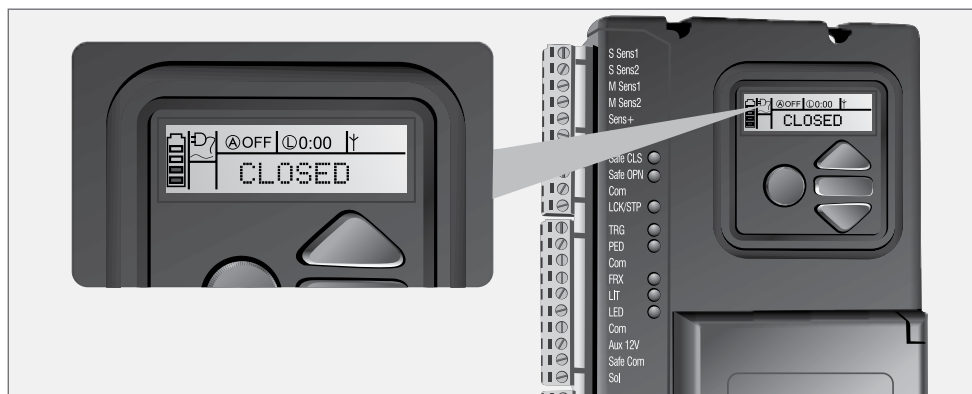

FIGURE 11. CONTROLLER LCD DISPLAY

3.2. Gate Operation

3.2.1. Full Gate Opening

The code-hopping remote controls are used to operate the gate in most instances. However, most automatic gate installations are also fitted with an intercom, which provides for communication between the house/building and the gate. The intercom handset is usually fitted with a gate/door release pushbutton which, when pressed, will operate the gate. Other devices such as keypads, GSM devices and access control card and biometric readers may also be interfaced with the system to operate the gate.

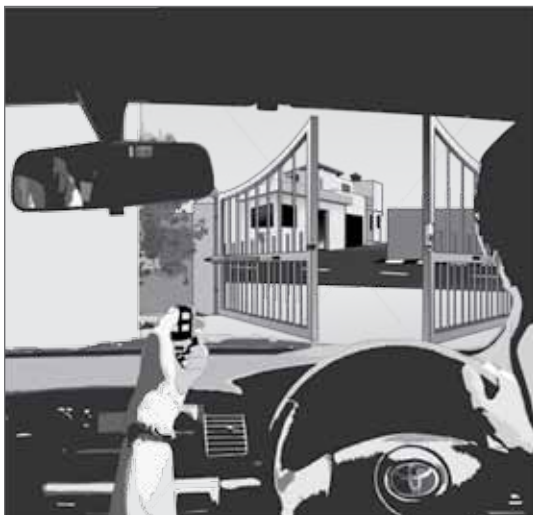

FIGURE 12

3.2.2. Modes of Operation

To operate the gate to open fully, the **V-Series** motors have a number of operating modes to choose from depending on the application. **Only one mode can be selected at any given time, unless indicated otherwise.**

1. **Standard Mode** (with selectable Autoclose feature)
2. **Reversing Mode** (with selectable Autoclose feature)
3. **Condominium Mode** (compulsory Autoclose)

3.2.2.1. Standard Mode

Standard Mode is the most commonly used mode for domestic applications as it allows for full control of the gate. Press the button of the remote control or the gate/door release pushbutton on the intercom for approximately one second to get the gate in motion.

If you press the button again while the gate is moving, the gate will stop. Press the button for a third time and the gate will reverse.



Autoclose and PIRAC (Beam Autoclose) can be used with Standard Mode. An Infrared Safety Beam needs to be installed across the gate entrance and connected to the Closing Safety Beam input on the V-Series Controller to use this function, in order to prevent the gate from closing on people, pets or vehicles.

3.2.2.2. Reversing Mode

Reversing Mode offers slightly more security than Standard Mode as it allows you to close your gate quickly by pressing, for instance, your remote control just as you drive through the gate to prevent children or pets running out - or anybody getting in behind you.

When triggering the gate motor via remote control, gate/door release pushbutton, mobile phone (if a GSM module has been fitted), or whatever means, your gate will be set in motion.



If the gate is opening and you press the button, the gate will stop and immediately start to close (and vice versa).

3.2.2.3. Condominium Mode

This mode is ideal for increased safety and security in multi-user applications such as townhouses, estates, factories or office parks. If you select Condominium Mode, your gate will open when pressing the button of the remote control or the gate/door release pushbutton on the intercom – but pressing the button again while the gate is opening will be ignored. It will not cause the gate to stop or to reverse. Only the internal Autoclose, which is automatically enabled in Condominium Mode, will close the gate. If the button of the remote control or intercom gate release is pressed while the gate is closing, the gate will immediately reopen. The gate cannot be stopped in a midway position and will therefore always close. If the button is pressed while the gate is in the open position, the Autoclose timer is reset.



The Autoclose Override feature cannot be applied in Condominium Mode.



We highly recommend that you use Infrared Safety Beams if you select Condominium Mode in order to prevent the gate from closing on people, pets or vehicles.



PIRAC (Passive Infrared Beam Autoclose) can be used with Condominium Mode.

3.2.3. Automatic Closing (Autoclose Mode)

The **V-Series** swing gate motors have the facility to automatically close the gate after it has opened. When enabling this feature, the time that the gate stays open is by default 15 seconds (this time is adjustable between one and 255 seconds).

As described in the previous section, Autoclose is selectable with Standard and Reversing Modes and by default the function is disabled. However, Autoclose is automatically enabled in Condominium Mode.



Centurion Systems (Pty) Ltd highly recommends that an infrared gate safety beam is installed across the gate entrance and connected to the Closing Safety Beam input on the **V-Series Controller** if you enable Autoclose Mode, in order to help prevent the gate from closing on people, pets or vehicles. It is possible to adjust the delay before the gate closes in one second increments from zero seconds to four minutes. The default time is 15 seconds.

3.2.3.1. Autoclose Override

Automatic closing can be overridden in Standard and Reversing Modes by pressing and holding the button of the remote control or intercom gate release for no less than three seconds. The gate response will be to start opening and then to stop as soon as the Autoclose Override feature is activated. On releasing the button, the gate will continue opening until fully open.

Your gate will stay open until you use the remote control or intercom gate release to close the gate. The gate motor will then revert to normal Autoclose operation.



The Autoclose function cannot be overridden in Condominium Mode.



It is possible to adjust the override time or the time required to hold down the button in order to override Autoclose in one second increments from one to ten seconds. The default time is three seconds.

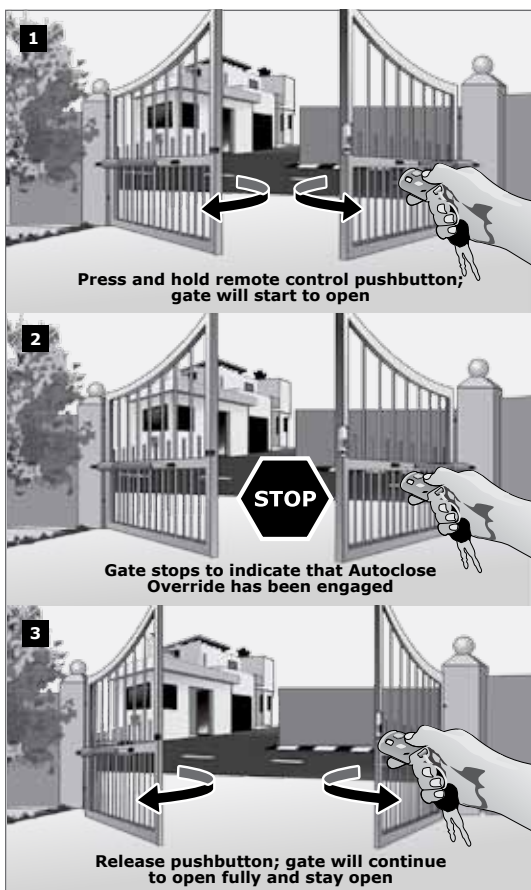

FIGURE 13

3.2.3.2. Autoclose Advanced Options

You can independently set Autoclose to function when the gate is partly open, fully open or partly closed.

For example, disable Autoclose when the gate is partly closed to allow construction workers, gardeners, etc. access to your property (although this comes with security risks). Enabling the Autoclose in all states of gate movement, ensures that the gate can never be left in any position other than fully closed. The default setting when enabling Advanced Autoclose is partly open and fully open, but not partly closed.

3.2.4. Pedestrian Opening

The Pedestrian Opening input opens only one leaf of a double leaf installation just wide enough for a pedestrian to pass through. A second button on your remote control can be used to operate the Pedestrian Opening function.

You can also set a keyswitch or keypad mounted adjacent to the gate entrance to operate this function.

There is a two second delay (default, but adjustable) before the gate opens to warn the pedestrian that the gate is about to move.



FIGURE 14

It is highly recommended that access control devices are placed in such a position that people do not need to reach through the gate in order to operate them in order to prevent possible injury in the event that the gate moves.



FIGURE 15



If a Courtesy Light is connected to the **V-Series Controller**, it will flash, indicating that the gate will open a default distance of approximately 30% of piston stroke. The gate will close after a default time of five seconds (adjustable).

The gate can be kept in the Pedestrian Opening position by, for example, keeping your key in the keyswitch. Once removed, the gate will close after the default five seconds.

The Pedestrian Opening Input is fully configurable and can be set to suit your needs. You can adjust the pre-opening time delay, the amount that the gate opens, and the pedestrian Autoclose delay using your LCD controller.

If a Safety Beam is fitted and the beam is broken while the gate is closing, the gate will stop and open to the pedestrian position. The gate will remain open while the beam is broken and the five second (adjustable) Autoclose delay will only commence once the beam has been cleared.



- **For safety reasons it is recommended that all pedestrian keyswitches and keypads are installed on the opposite end of the gate to where the motor is installed**
- **It is possible to adjust the delay before the gate opens in one second increments from zero to 240 seconds (four minutes); the default time is two seconds**



- It is possible to adjust the width of the Pedestrian Opening from a minimum of 10% of piston stroke to the full gate opening in 1% increments; the default opening is 30% of piston stroke
- It is possible to adjust the delay before the gate closes in one second increments from zero to 240 seconds (four minutes); the default time is five seconds

3.2.5. Free-exit Opening

The Free-exit Opening allows visitors to exit townhouses, estates, factories or office parks easily.

An inductive ground loop is mounted under the driveway inside the property a short distance away from the gate. The output of the inductive ground loop detector is connected to the free-exit (FRX) input on the controller.

When a vehicle drives over the loop, a detector senses the metal in the vehicle and activates the free-exit function which opens the gate.

The ground loop cannot be activated by a person or any non-metallic objects and can be set to only activate if it detects a large amount of metal.

Free-exit never initiates a closing cycle, so the Autoclose function must be enabled in order for the gate to close. If the gate is already open or opening, triggering the free-exit input will have no effect other than to reset the Autoclose timer. If the gate is closing, triggering the free-exit input will immediately stop and re-open the gate.

An Infrared Beam can be used instead of an inductive ground loop, but the beam will be activated if a person (or any object) moves through it, so this option is typically less secure.

Please contact Centurion Systems (Pty) Ltd for more information on whether a ground loop or infrared beam is better suited to your needs.

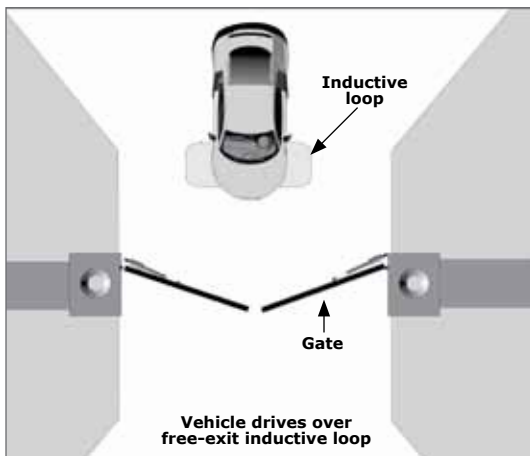

FIGURE 16



FIGURE 17

3.2.6. PIRAC Mode (Beam Autoclose Mode) - Optional



This mode can only be used if a Closing Safety Beam is fitted.

This mode can be used in conjunction with any of the operating modes - Standard, Condominium and Reversing Mode.

With PIRAC Mode enabled, your gate will close as soon as you have driven through and passed the Closing Safety Beam – giving intruders no time to follow behind you.

If Autoclose is enabled and the gate has been opened but nothing moves through the Closing Safety Beam, the gate will stay fully open for the duration of the Autoclose timer before closing. However, if something passes through the Closing Safety Beam the gate will close immediately.

If something crosses the beam while the gate is opening, it will continue to open until the beam is cleared and the gate will then stop and close. If the gate has reached its fully open position, it will stop and remain open until the beam is cleared or the Autoclose timer expires, whichever occurs first.

- 
The two Closing Safety Beams may not be further apart than the shortest vehicle using the installation/gate
- Failure to adhere may result in the gate closing on a vehicle or pedestrian**

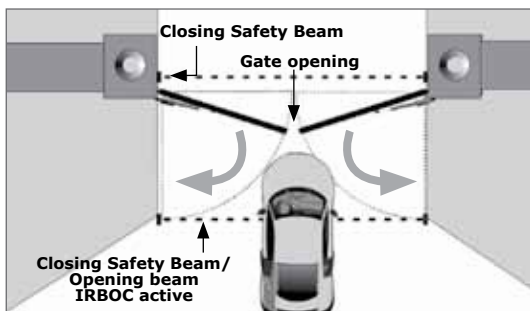

FIGURE 18

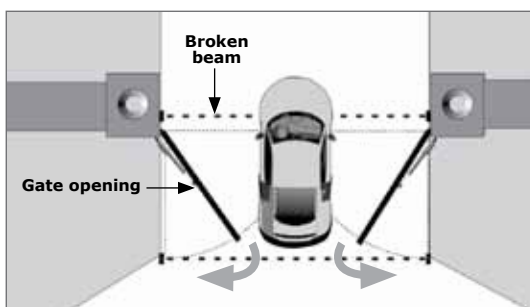

FIGURE 19

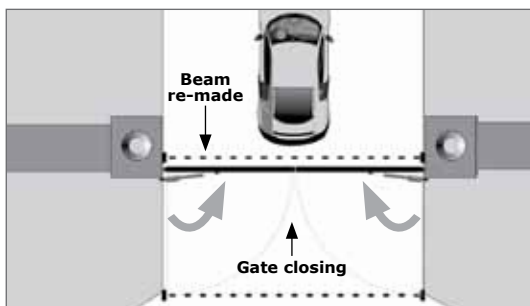

FIGURE 20

3.2.6.1 PIRAC Override

PIRAC (Beam Autoclose) Mode can only be overridden in Standard and Reversing Modes. Similar to overriding the Autoclose function you must press and hold the button of the remote control or intercom gate release for at least six seconds. The gate response will be to start opening and then to stop for a pause time of three seconds and then continue to open as soon as the PIRAC Override feature is activated. Once the gate resumes opening, you may release the remote control button or intercom gate release and the gate will continue to the fully open position with PIRAC Mode overridden.

Your gate will stay open until you use the remote control or intercom gate release to close the gate. The motor will then revert to normal PIRAC operation.

3.2.7. Holiday Lockout Mode

This feature completely immobilises the motor and deactivates all inputs (remote controls, intercom gate button, keypads, etc.) so nobody can get into your property while you are away.

Holiday Lockout Mode can be activated by one of the buttons on your remote control as well as a latching keyswitch or keypad mounted adjacent to the gate entrance, accessible from the outside of the property.

When Holiday Lockout Mode is enabled, any of the **access control** devices that are connected to the **V-Series Controller**, will be inactive and not even tampering with the keyswitch, keypad or access

tag readers on the outside of the property will open the gate – particularly useful if you intend leaving your property unattended for extended periods of time.

If Holiday Lockout Mode is enabled while the gate is moving or in the open position, it will only activate when the gate returns to the closed position.



If somebody tries to open the gate via a valid access control device, such as a remote control, etc. with Holiday Lockout Mode enabled, the onboard buzzer will beep five times after each activation.

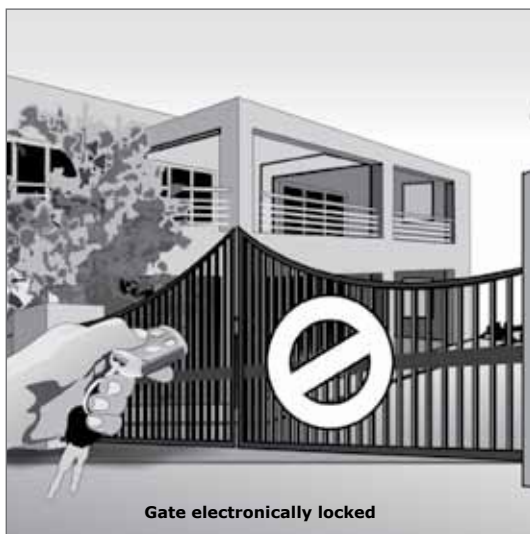

FIGURE 21

3.2.8. Positive Close Mode

Positive Close Mode (PCM) allows the gate to drive up hard to an endstop without causing the anti-crush mechanism to operate. This feature only operates during the last few millimetres of piston travel when the gate is closing.

This feature is used to firmly engage two leaves together of a double swing gate installation without having to fit mechanical endstops. A mechanical 'lip' is fitted to one leaf which will push up against the other leaf, and with PCM enabled it will keep pushing until the gates are mechanically locked.

To ensure that the gates do not close past their desired end point, the leaf against which the leaf with the mechanical lip pushes can be preset to stop slightly short of its closed position. This is referred to as the 'Short Stop' distance. If the 'Short Stop' distance is correctly set, the pushing leaf will engage with the other leaf sufficiently before the closed position and via the PCM, push the two leaves into the fully closed position, but no further.

Contact your gate automation specialist for assistance.



The Positive Close Mode feature can be enabled on either or both leaves of a double swing gate installation in addition to adjusting the amount of force applied by the motor.

3.2.9. Positive Open Mode

Setting Positive Open Mode to **ON** will allow the gate to drive up hard to the **OPEN** endstop without causing the collision circuitry to operate. This feature operates only during the last few millimetres of gate travel in Opening Mode, and ensures that the gate(s) remain(s) firmly attached to the endstop and is/are less likely to move in windy conditions, which can be detrimental to the motor gearbox and gate hinges.

The Positive Open Mode feature can be enabled on either or both leaves. It is also useful in instances where electric gate locks have been fitted in the open position.

3.2.10. Motor Run Profiles

In order to set up the system for optimum performance a number of the operating parameters can be adjusted via the controller.

The opening and closing speeds of the gate can be independently set but are common between the two leaves of a double swing gate installation. The ramp-up to full speed and the ramp-down to the crawl speed before the gate stops can also be adjusted.

The distance that the gate moves at its crawl speed before stopping can also be set.

Please contact Centurion Systems (Pty) Ltd for more information on finding the configuration that is best for you.

3.3. Gate Lock

The **V-Series Controller** provides a 12V supply to drive either an electric solenoid or magnetic lock. Both the lock pre-release time (time before the gate starts to move) and the release time (time while the gate is moving) can be adjusted in addition to being able to specify whether the gate is locked in either the open or closed position or both.

Finally, the supply can be set to either AC or DC where with AC, the **V-Series Controller** will power the lock with a 50Hz square wave.

Contact Centurion Systems (Pty) Ltd or your gate automation specialist for assistance.

3.4. Anti-crushing Sensitivity

The **VECTOR2**, **VERT-X** and **VANTAGE** incorporate a sensitive electronic anti-crushing technology that activates if a person or vehicle obstructs your gate.

If the anti-crushing circuitry is invoked during the opening cycle, the controller will stop the gate. The second gate leaf (if fitted for a double-swing system) will continue to open.

If the anti-crushing circuitry is invoked during the closing cycle, then both leaves will re-open, regardless of whether the anti-crushing mechanism on one or both leaves senses the obstruction. As per the above, when triggering the system again, the gate will close.

Once the obstruction is cleared, the obstructed gate can immediately be operated using the remote control, or gate release pushbutton.

Collision Force (Sensing) (anti-crushing sensitivity) can be set independently per direction of travel and can be set from minimum to maximum in five incremental steps.

A sixth incremental step will disable Collision Sensing entirely and allow for maximum force – the motor will run until it stalls, at which point a collision will be detected.



The sixth step referred to above, should only be used if additional safety measures such as infrared beams are present.

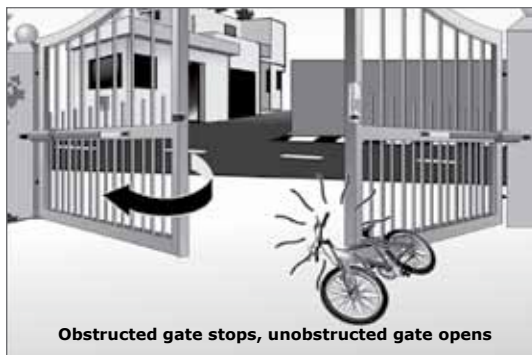

FIGURE 22



FIGURE 23

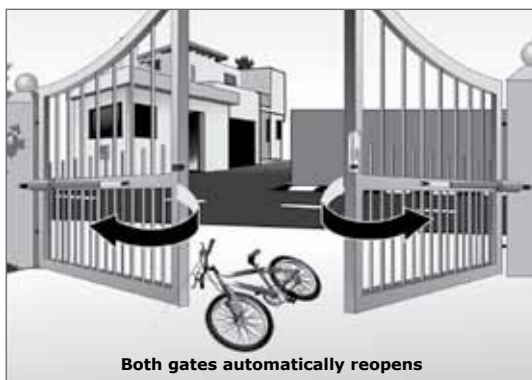

FIGURE 24

3.4.1. Collision Count

A counter monitors the number of collisions the gate experiences before it fully closes. If the number exceeds the default value of four, which can be adjusted in the Multiple Collisions Counter, the controller will shut down. The Status LED will flash four times every two seconds until a valid trigger is received.

Please refer to Gate Status Indication for more information on this diagnostic device.

3.5. Infrared Safety Beams

3.5.1. Closing Safety Beams

Closing Safety Beams provide additional protection against your gate closing on people, pets or vehicles.

If the closing beam is broken while the gate is opening, it will continue to open. If the gate is open, the gate cannot be closed and if the gate is closing, it will stop and reopen.

If you select the Autoclose feature, the gate will remain open while the beam is broken; once the beam has been cleared the gate will close, only after the Autoclose time has expired.

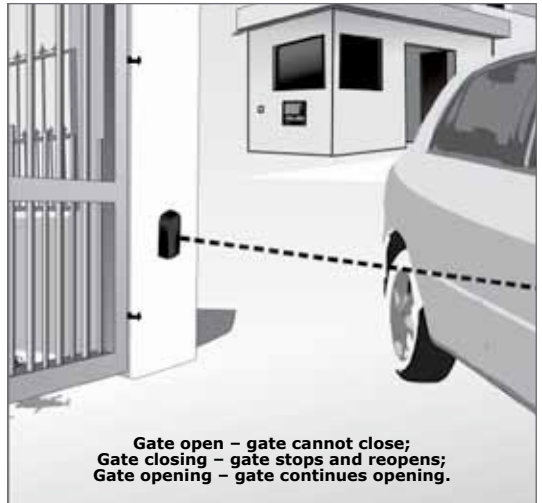

FIGURE 25

3.5.2. Opening Safety Beams

These beams prevent your gate from opening if an object or person is in the way.

If the beam is broken while the gate is closed, the gate will not open. If the gate is opening, it will stop. If the gate is closing, it will continue to close.

Please contact Centurion Systems (Pty) Ltd for more information on suitable protection devices.

3.6. Intruder-detection Alarms ¹ (a world first)

3.6.1. Ambush Alarm

Once activated, if the opening or closing beams are continuously interrupted for a predefined time, the Ambush Alarm will sound. Intruders often cover beam lenses, thus breaking the beam, so your gate stays open after you have entered or left your property – but with the Ambush Alarm enabled you can be instantly alerted to any criminal activity.



FIGURE 26

3.6.2. Break-In Alarm

If the closing beam on the outside of your property is interrupted, the Break-in Alarm will sound and continue to sound for 30 seconds after the beam is re-made.

Intruders will not be able to loiter outside your property as the Break-In Alarm will immediately alert you of their presence – and the noise of the onboard buzzer is often an effective deterrent. Optionally, the alarm signal can be routed to an armed response company, or an external warning device.



FIGURE 27

If either the Ambush Alarm ¹ or Break-In Alarm ¹ is utilised, the system may be configured to operate one of the following outputs provided on the **V-Series Controller**:

- Onboard buzzer – emits a continuous tone
- Pillar/Courtesy Light contact
- Safety Beam common
- Status LED output
- Auxiliary IO (which can be used to connect to a third party alarm and security company, or a CENTURION G-SWITCH-22 device to alert you of the alarm via SMS) or a sound bomb which will make a loud noise at the motor.



It is typical to select only one of the alarm features.

1. Requires infrared gate Safety Beams to be installed

3.7. External Gate Status Indication

An LED (Light Emitting Diode) mounted on your intercom allows you to view the position of your gate and the condition of the battery and power supply from the safety of your home. The different signals of the LED are described in the table below:

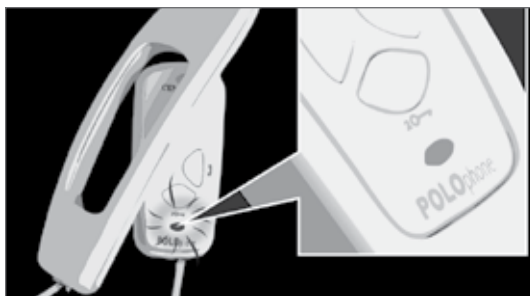

FIGURE 28

LED Signal	Diagnosis
Off	Gate is closed
On	Gate is partially or fully open
Continuous slow flash	Gate is opening
Continuous fast flash	Gate is closing
One flash every two seconds	Courtesy (Pillar) lights on
Two flashes every two seconds	No mains present
Three flashes every two seconds	Battery voltage is low
Four flashes every two seconds	Multiple collisions have occurred



If you choose not to fit a Gate Status Indicator, the Status LED on the Controller can also be used for troubleshooting.

3.8. Courtesy (Pillar) Light Timer

Courtesy (Pillar) Lights (optional) can be connected through the controller if a 220V power supply is available at the gate. The lights will switch on every time the gate is given a signal to operate and stay on for an adjustable period of one second to ten minutes (in increments of one second) then automatically turn off.



FIGURE 29

The purpose is to bathe your entrance with light when you open the gates and increase your security as you drive into your property – it also saves electricity as the lights only come on when you use the gate motor.



Using the Pedestrian Opening feature will cause the Courtesy (Pillar) Lights to flash three times before the gate opens. This is a safety feature to protect the pedestrian.

3.8.1. Courtesy (Pillar) Light Control

The Courtesy (Pillar) Lights can be switched on from inside your home or office by connecting a pushbutton to the **V-Series Controller**.

For your safety this pushbutton switches only low-voltage signals.

Press and release the button for the lights to switch on for the defined period then switch off automatically. Press and hold the button for three to four seconds for the lights to stay on permanently, until you push the button again. If the Gate Status Indicator is fitted to the intercom handset, the LED will flash once every two seconds to indicate that the lights are on permanently.

This feature can also be operated using your remote control. Simply set one of the spare buttons on the transmitter to switch your Courtesy (Pillar) Lights on and off.

Please refer to Onboard Multichannel Receiver for more information on the various functions you can operate with your remote control.

Low-wattage, 12V DC light fittings are also readily available and can be connected to the system, drawing power directly from the battery. However, please ensure that the power drawn by the lights and motor does not exceed the recharge rate of the battery. Larger charger units can be fitted to cope with the additional load – contact your gate automation specialist or Centurion Systems (Pty) Ltd for more information.

3.8.2. Courtesy (Pillar) Light acts as Warning Light

For additional safety, the Courtesy (Pillar) Light output can be configured to act as a Warning Light before the gate operates and while the gate is moving.

Contact your gate automation specialist or Centurion Systems (Pty) Ltd for more details on the different Warning Light Modes.



FIGURE 30

3.8.3. Pre-open and Pre-close Delays

If you make use of the Warning Light feature, you can set your gate to have a slight delay before it opens or closes to allow the light to warn pedestrians or vehicles that the gate is about to move.

The Pre-open and Pre-close Delays can be independently set and can also be used independently of the Warning Light feature referred to above.

3.9. Onboard Multichannel Receiver

The **V-Series Controllers** are supplied standard with a multichannel receiver compatible with our secure code-hopping encryption. The receiver will allow any combination of the different inputs (such as Trigger, Pedestrian, Holiday Lockout, etc.) to be operated from a single multi-button remote control.



FIGURE 31

You can artificially increase the number of buttons of a multi-button remote control by using a two-button combination. One of the buttons is used as a **Shift Button** to allow the other buttons to be used again in combination with this button. Press and hold the **Shift Button** and then press one of the other buttons to create a new button. The **Shift Button** cannot be used as a button on its own; it must always be used in combination with another button.

Use of the **Shift Button** principle allows a three-button transmitter to gain an extra button and operate four functions and a four-button transmitter gains two extra buttons and can operate six functions.

This is quite handy if you'd like to control additional devices from a single multi-button remote control, for example, your garage doors if they are equipped with compatible code-hopping receivers.

However it's also important to note that other devices cannot be activated with the new Shift Button, only the **VECTOR2**, **VANTAGE** and **VERT-X** (and other motors from Centurion Systems (Pty) Ltd that are equipped with an onboard receiver) are able to recognise the shift button signals. Using a Shift Button also prevents you from enabling functions like Holiday Lockout Mode by accident because you have to use both hands to press the two-button combination.

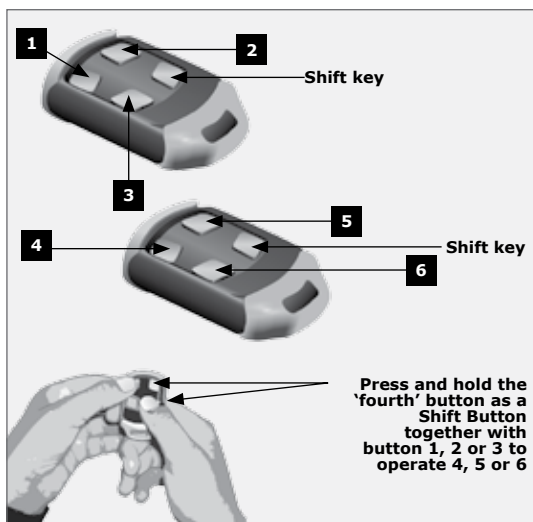

FIGURE 32

Another function provided with this receiver is the ability to record the memory location of each remote control, mapping this to the name of the owner of the remote.

This allows any transmitter, if recorded, that is lost or stolen to be selectively erased from the system without affecting any of the other remotes installed.

It is also possible to erase the functions of certain buttons on a remote control if they're no longer required. Alternatively, the functionality of certain buttons can be changed to trigger different functions.

At any stage remote controls can be selectively added, deleted or edited within the system.

Contact your gate automation specialist or Centurion Systems (Pty) Ltd for assistance.

3.10. Battery-Low Protection

The controller has circuitry that monitors the state of the battery. During a power failure, energy is drawn from the battery, but is not replaced. To prevent the battery from being run totally flat, and being damaged, the protection circuitry shuts off the gate system when the battery voltage drops below 10.6V.

The Gate Status Indication LED will flash three times every two seconds and the controller LCD will state 'Battery-Low'. The gate will complete its current cycle and then shut down until the battery has recovered.

If you see the Battery-Low signal, check that the power circuit feeding the gate motor is switched on. Otherwise, contact your local gate automation specialist or Centurion Systems (Pty) Ltd for assistance.

4. Additional Features

4.1. Solar Power Supply

A solar panel can be used to charge the battery instead of the conventional charging circuit. A 20W panel will provide enough power for 20 operations (less if 12V DC security lights are fitted) on an average gate.

You will need to fit a deep-cycle low-maintenance battery (minimum 35Ah) in order to provide sufficient backup capacity during days of poor weather.



FIGURE 33

The charger supplied with the standard **V-Series** system must also be replaced with a high-efficiency solar regulator.

These are typical values for Southern Africa. Contact Centurion Systems (Pty) Ltd or your gate automation specialist for details on what solar panel to select in your area.

4.2. Lightning Protection

The **V-Series Controller** has onboard lightning protection.

The protection circuitry was originally designed in conjunction with the South African Centre for Scientific and Industrial Research (CSIR). It is, however, important to realise that the controller's protection only functions correctly if an adequate lightning-earth is fitted during installation.

Contact your gate automation specialist for assistance.



Lightning damage is not covered under the normal warranty of the equipment.

4.3. Leaf Delay

Some double swing gate installations are designed with one of the leaves having a mechanical 'lip' to cover the gap between the leaves when they are closed. With others a lock is fitted to one of the leaves in addition to the 'lip'.

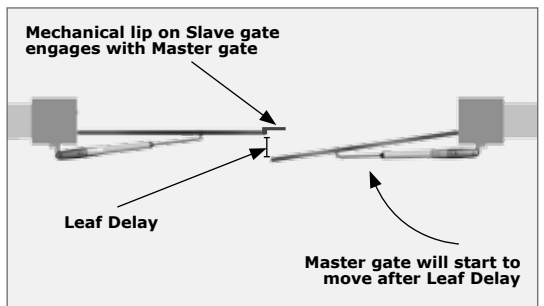

FIGURE 34

The **V-Series Controller** has the ability to set a leaf delay so that the one leaf opens before the other in order to prevent the two leaves obstructing each other due to the 'lip' and/or the lock.

Likewise, when the gate closes the controller will ensure that the two leaves are properly synchronised so that it closes properly.

The Leaf Delay can be adjusted and this is measured in millimetres of motor piston travel.

Contact Centurion Systems (Pty) Ltd or your gate automation specialist for assistance.

5. Basic Maintenance

Motors from Centurion Systems (Pty) Ltd are designed to be maintenance-free. However, there are some basic checks that should be carried out regularly (every six months). These checks will increase the long-term reliability of the system and prevent erratic operation of your gate.



Isolate Mains supply and disconnect the battery before cleaning or working on the system.

5.1. General Maintenance

1. Remove all shrubs and vegetation which may interfere with the gate opening or closing correctly.
2. Make sure that all terminals are tight and that the terminals are firmly plugged into the sockets on the **V-Series Controller**.
3. Keep the inside of the control housing clear of insects and dirt.
4. Grease the gate hinges to ensure that the gate swings freely.
5. Spray a good quality insect spray on the wall surrounding the controller housing.
6. Do not spray onto or inside of the housing itself.
7. Ensure that the manual release Camlocks work correctly and lubricate as necessary.
8. A graphite powder lubricant is better than oil, or grease, as it does not attract dust.
9. Ensure that the Camlock covers are closed to prevent the ingress of dust and insects.
10. If padlocks (optional extra) are fitted to the pins securing the motor to the gate and Wall Brackets, then check that these padlocks can be opened.
11. Lubricate padlocks as required, particularly during the rainy seasons.
12. Check that the motor Wall Mounting Brackets are still securely fixed to the gate pillar or wall. Similarly, examine the condition of the fixing of the Gate Brackets to the gate itself. There are very large forces applied to all the brackets and they can be worked loose.

5.2. Battery

The maintenance-free lead acid batteries fitted to the **V-Series** motors should provide at least three years of normal service life.

For sites utilising an external large capacity ($\pm 35\text{Ah}$) low-maintenance battery, ensure that the level of liquid (electrolyte level) is correct.



In all instances check for corrosion of the battery terminals. Clean and apply copper-based grease as necessary.

5.3. Charger

The **V-Series** motors have chargers separate to the main **V-Series Controller**. In the case of product malfunction, the charger fuse should be checked, but only by a qualified electrician.

Always isolate the Mains supply to the motor before attempting to remove and check the fuse.



Check the 'Mains Present' icon on the main diagnostic screen. Each charger has a red light (LED) to indicate Mains supply.



Do not attempt to repair the unit yourself. Any work performed by unauthorised personnel may void the warranty.

6. Diagnostics

Depending on the type of fault or condition of the motor, audible feedback will be given via the onboard buzzer. Listen out for this and refer to the table below:

The different conditions are given in order of precedence:

Break-in Alarm – if the safety beam has been broken with this feature set, the buzzer will emit one beep periodically for 30 seconds. Refer to page 29 for a full explanation of this feature.

Ambush Alarm – if the safety beam has been broken with this feature set, the buzzer will emit one beep periodically until the safety beams have been cleared. Refer to page 29 for a full explanation of this feature.

Multiple Collision – Buzzer will beep periodically until condition is cleared. Refer to section, Anti-crushing, Collision Count

Holiday Lockout – If Holiday Lockout Mode has been enabled, when triggering to operate the gate, the gate will not operate but the buzzer will emit five beeps after each activation

Contact Centurion Systems (Pty) Ltd or your gate automation specialist for assistance.



Do not attempt to repair the unit yourself. Any work performed by unauthorised personnel may void the warranty.

7. Troubleshooting Guide

This is a basic checklist for your gate automation system. Should you experience a fault with the system, see if the symptom corresponds to any given in the list below.

For each symptom listed, the probable cause and action to be taken is given.

Terminals and LEDs referred to in the faultfinders table usually refer to those found on the **V-Series Controller** in the enclosure that is usually mounted on the gate pillar closest to the Master motor.

In the event of the symptom not being listed, consult your installer or Centurion Systems (Pty) Ltd for assistance.





Prior to working inside the V-Series Wall Box enclosure, ensure that the mains supply to the system has been isolated. With the battery connected, the actuator will remain operational.



As this product is used outside of the control of the manufacturer, neither Centurion Systems (Pty) Ltd, nor any of its subsidiaries, can be held liable for consequential damage as a result of the end-user attempting to maintain the unit without the assistance of a qualified installer.

Symptom	Cause	Action
Gate does not open or close fully, or gate moves a short distance and then stops.	There is an object obstructing the movement of the gate.	INDICATION: STATUS LED will be flashing four times per two seconds and the LCD on the Controller will show 'Collision Detected - Trig to reset'. Clear any obstructions from the gate.
Gate does not open or close fully, or gate moves a short distance and then stops.	Anti-crushing device setting is too sensitive.	Disconnect the motor from the gate by removing the pin from the Gate Bracket. Check that the motor operates correctly without the gate connected. Consult your installer if the problem persists.
Gate does not open or close fully, or gate moves a short distance and then stops.	Position control system is malfunctioning.	Check that the cables from the actuator are terminated correctly and making good contact. Consult your installer if the problem persists.

Symptom	Cause	Action
Gate does not open or close fully, or gate moves a short distance and then stops.	Battery voltage is low and the battery-low protection has activated.	<p>INDICATION: STATUS LED will be flashing three times per two seconds and LCD display will indicate 'Battery-Low' symbol (). Check that the battery is charging. (Check LCD display for correct 'Charging' symbol().</p> <p>Check that the Mains supply to the system is connected and switched on. The red gate status LED either on the V-Series Controller, or inside the house (if fitted), will flash twice every two seconds if the mains supply is not present and the LCD display will indicate 'No Mains' symbol.</p> <p>Check that battery connections are tight and that there is no corrosion.</p> <p>Check when the battery was last changed? The lifespan of the 7Ah maintenance-free battery supplied with the system is typically up to three years.</p>
Gate does not operate but you hear a relay click (the LCD display may indicate that the gate is opening).	Motor fuse blown on the control card.	Replace the blown 15A ATO fuse (typically used in motor cars) and make sure that the motor fuseholders are making good contact.
Gate does not operate but you hear a relay click (the LCD display may indicate that the gate is opening).	Battery voltage is low.	See action earlier in this troubleshooting guide for 'Battery voltage is low' and the battery-low protection is being activated.

Symptom	Cause	Action
<p>Gate does not operate and there is no reaction from any of the relays on the V-Series Controller either. (If the remote control button is pressed, only the radio receiver relay 'clicks').</p>	<p>Gate lock not releasing.</p>	<p>Solenoid Lock: Check that the lock is trying to release. It will make a distinctive 'click' sound when energised. Then check that the lock is not being mechanically held due to misalignment, dirt, etc.</p> <p>Magnetic Lock: Pull on the lock when activating the gate to release and feel whether the lock is releasing. Try disconnecting the lock (remove wire from terminal marked 'Sol').</p> <p>Consult your installer if the problem persists.</p>
<p>Gate does not operate and there is no reaction from any of the relays on the V-Series Controller either. (If the remote control button is pressed, only the radio receiver relay 'clicks').</p>	<p>There is an incorrect trigger input to the controller causing it to malfunction.</p>	<p>Check that the GREEN LEDs adjacent to the the 'Safe CLS' and 'Safe OPN' inputs on the V-Series Controller are ON.</p> <p>Check that the GREEN 'LCK/STP' (Holiday Lockout) LED is ON.</p> <p>Check that the other RED input LEDs (e.g. 'TRG', 'PED', 'FRX', etc) are OFF. They must only light up when the corresponding input is activated.</p> <p>Try operating the system using the RUN (▶) pushbutton on the V-Series Controller.</p> <p>Consult your installer if the problem persists.</p>

Symptom	Cause	Action
Gate does not close automatically (Autoclose Mode does not seem to work).	Infrared beam(s) (if fitted) is (are) faulty.	<p>Check that the GREEN LEDs adjacent to the 'Safe CLS' and 'Safe OPN' inputs are ON when the infrared beams are clear (unobstructed).</p> <p>Check that infrared beams are correctly aligned. It should be possible to hear the relay within the 'receiver' side of the infrared beam 'click' as the beam is broken and cleared.</p>
Gate does not Autoclose.	Check that the Autoclose override facility is not being operated.	Ensure that nobody is mistakenly pressing and holding down the gate-release pushbutton on either the remote or intercom for too long when activating the unit. Refer to section Autoclose Override.
Operator drives too far and does not stop in the correct open and closed positions.	<p>Origin system not functioning correctly.</p> <p>Origin position has been shifted.</p>	<p>Check that the cables from the actuator are terminated correctly and making good contact. Consult your installer should there be a problem.</p> <p>Make sure that the origin clamp has not shifted position on the piston. Consult your installer should this be suspected.</p>
Gate opens on its own.	Permanent input on one of the trigger lines to the controller.	<p>Check that the RED LEDs adjacent to each trigger input on the controller ('TRG', 'FRX' and 'PED') are OFF and only switch ON when that input is activated.</p> <p>Consult your installer if there is a problem.</p>

Symptom	Cause	Action
Remote control has poor range.	Remote control's battery is flat. Radio receiver cannot receive transmitter signal properly.	Check that the fault only occurs with one of the remote controls; replace battery. Make sure that the aerial on the receiver is straight. Consult your installer if problem persists.
Master Gate opens to the Pedestrian Opening position and closes.	Keyswitch (where applicable) used for activating the Pedestrian Opening function is faulty. Anti-crushing device is set too sensitively.	Check for corrosion of the wire terminations behind the keyswitch. Consult your installer if the problem persists.
External gate Courtesy/ Pillar Light does not operate.	Light fuse blown. Light bulb blown.	<p>CAUTION HIGH VOLTAGE, make sure Mains supply to system is isolated.</p>  <p>Replace fuse - 220V 3A Fast Blow. Pillar Light terminal plug-socket is not plugged in correctly. Check that the lamp load does not exceed 500W. Check the bulb and replace if necessary; make sure that the bulb is making good electrical contact in its holder.</p>

8. Technical Specifications

8.1. VECTOR2 Technical Specifications

	VECTOR2 400	VECTOR2 500
Input voltage	90V ¹ - 240V AC \pm 10%, 50/60Hz	
Motor voltage	12V DC	
Motor power supply	Battery-driven (standard capacity - 7Ah) ²	
Battery charger ³		
Domestic ⁴	CP84E - 800mA @ 13.8V	
Light-industrial ⁵	CP84SM - 2A @13.8V	
Current consumption (Mains)	60mA ⁴ / 170mA ⁵	
Current consumption (motor at rated load)	15A - maximum	
Operator push force - maximum	250kgf	
Operator stroke	400mm	500mm
Piston extension/retraction speed	27mm/sec	
Typical gate opening time ⁶	14 sec	17 sec
Manual override	Key release ¹⁰	
Maximum number of operations per day	100 ⁴ /250 ⁵	
Duty cycle - mains present ^{7 8}	25% ⁴ /50% ⁵	
Operations in standby with 7Ah battery ⁹		
Half day	70	
Full day	58	
Collision Sensing	Electronic	
Operating temperature range	-15°C to +50°C	
Onboard receiver type	Code-hopping multichannel	
Receiver code storage capacity	64 transmitter buttons	
Mass of unit packed (excluding battery)		
Single kit	8.5kg	9kg
Double kit	14kg	15kg

TABLE 1

1. Applies to CP84SM light-industrial unit only
2. Can increase battery capacity for longer standby times
3. Can operate off a solar supply, consult Centurion Systems (Pty) Ltd for assistance
4. Domestic
5. Light-industrial
6. Assumes full stroke of motor is used
7. Based on 25°C ambient temperature and unit not in direct sunlight
8. Based on an motor push force of less than 50% of rated
9. Based on double kit excluding Infrared Safety Beams
10. Each unit comes with a unique set of keys

8.2. VANTAGE Technical Specifications

	VANTAGE 400	VANTAGE 500
Input voltage	90V - 240V AC \pm 10%, 50/60Hz	
Motor voltage	12V DC	
Motor power supply	Battery-driven (standard capacity - 7Ah) ¹	
Battery charger ²	1.8A @13.8V	
Current consumption (Mains)	170mA	
Current consumption (motor at rated load)	15A - maximum	
Operator push force - maximum	250kgf	
Operator stroke	400mm	500mm
Piston extension/retraction speed	28mm/sec	
Typical gate opening time ³	14.3 sec	17.8 sec
Manual Override	Key release ⁴	
Maximum number of operations per day	250	
Duty cycle - Mains present ^{5 6}	50%	
Operations in standby with 7Ah battery ⁷		
Half day	70	
Full day	58	
Collision Sensing	Electronic	
Operating temperature range	-15°C to +50°C	
Onboard receiver type	Code-hopping multichannel	
Receiver code storage capacity	64 transmitter buttons	
Receiver frequency	433MHz	
Mass of unit packed (excluding battery)		
Single Kit	10.9kg	11.4kg
Double Kit	19.9kg	20.9kg

TABLE 2

1. For longer standby times, battery capacity can be increased
2. Can operate off a solar supply, consult Centurion Systems (Pty) Ltd for Assistance
3. Assumes full stroke of motor is used
4. Each unit comes with a unique set of keys
5. Based on 25°C ambient temperature and unit not in direct sunlight
6. Based on an motor push force of less than 50% of rated
7. Based on double kit excluding Infrared Safety Beams

8.3. VERT-X Technical Specifications

	VERT-X
Input voltage	90V - 240V AC \pm 10%, 50/60Hz
Motor voltage	12V DC
Motor power supply	Battery-driven (standard capacity - 7Ah) ¹
Battery charger ²	1.8A @ 13.8V
Current consumption (Mains)	170mA
Current consumption (motor at rated load)	15A - maximum
Operator push force - maximum	250kgf
Operator stroke	300mm
Piston extension/retraction speed	28mm/sec
Typical gate opening time ³	11 sec
Manual Override	Key release ⁴
Maximum number of operations per day	250
Duty cycle - Mains present ^{5 6}	50%
Operations in standby with 7Ah battery ⁷	
Half day	70
Full day	58
Collision Sensing	Electronic
Operating temperature range	-15°C to +50°C
Onboard receiver type	Code-hopping multichannel
Receiver code storage capacity	64 transmitter buttons
Receiver frequency	433MHz
Mass of unit packed (excluding battery)	
Single Kit	9.9kg
Double Kit	17.9kg

TABLE 3

1. For longer standby times, battery capacity can be increased
2. Can operate off a solar supply, consult Centurion Systems (Pty) Ltd for Assistance
3. Assumes full stroke of motor is used
4. Each unit comes with a unique set of keys
5. Based on 25°C ambient temperature and unit not in direct sunlight
6. Based on an motor push force of less than 50% of rated
7. Based on double kit excluding Infrared Safety Beams

9. 24 Month Carry-in Product Warranty



You can register your product(s) online at www.CentSys.com, which will assist you in keeping a record of your date of purchase or installation, serial numbers, etc.

All of our products are manufactured with extreme care, thoroughly inspected and tested.

The goods supplied by us shall be subject to the provisions of sections 55 to 57 of the Consumer Protection Act (68/2008) except where the provisions of the warranty contained in our product documentation are more favourable to the purchaser. Subject to the warranty contained in our product documentation, if applicable, our products are warranted for a period of twenty-four months after delivery. However, it is expressly noted that batteries carry a six month warranty due to the nature of these products being such that they are subject to possible misuse. Please note that warranties will be honoured on a carry-in basis; in other words, the product in question must be taken in to one of our branches, or to the authorised reseller that the product was purchased from, for assessment and, if necessary, repair. For equipment not of our manufacture, the warranty as supplied by the original manufacturer will apply if such warranty is more favourable to the purchaser than the relevant provisions of the Consumer Protection Act (Act 68/2008 of South Africa), or any other applicable law as so required in different countries in which the product was sold. Such warranty is valid only once full payment has been received for such goods.

Australian customers:

Our goods come with guarantees that cannot be excluded under the Australian Consumer Law. You are entitled to a replacement or refund for a major failure and compensation for any other reasonably foreseeable loss or damage. You are also entitled to have the goods repaired or replaced if the goods fail to be of acceptable quality and the failure does not amount to a major failure..

Any warranty may be voidable on any equipment which:

1. Has not been installed in accordance with the installation instructions provided.
2. Has been subject to misuse or which has been used for any purpose other than that designed for by the manufacturers.
3. Has damage caused as a result of handling during transit, atmospheric conditions (including lightning), corrosion of metal parts, insect infestation, power surges or other forces outside of the control of the manufacturer.
4. Has been repaired by any workshop and / or person NOT previously authorised by the manufacturer.
5. Has been repaired with components not previously tested, passed or authorised by Centurion Systems (Pty) Ltd, South Africa or one of its subsidiary companies.

We will not be liable under this contract for any loss or damage caused by us or our employees or agents in circumstances where:

1. There has been a failure to install the product in accordance with the installation instructions provided by the manufacturer, or
2. a failure to abide by the safety instructions provided by the manufacturer, or
3. there is no breach of a legal duty of care owed to you by us or by any of our employees or agents
4. such loss or damage is not a reasonably foreseeable result of any such breach, and any increase in loss or damage resulting from breach by you of any term of this contract.

10. Optional Extras

Photon/i5 Infrared Safety Beams

Always recommended on any gate automation installation.

SMARTGUARD and SMARTGUARDair keypad

Cost-effective and versatile wired and wireless keypads, allowing for access to pedestrians, armed response companies, etc.

SOLO/Lattice Proximity Access Control System

Proximity reader, allowing for access to both pedestrians and vehicles.

Pedestrian Keyswitch

Allows for pedestrians to partially open the gate using a key.

POLOphone Intercom System

Allow visitors to communicate with residents in order to gain access to the property.

G-SPEAK 2G GSM-based Intercom System

Mobile-based intercom system - answer your intercom from anywhere in the world with a 2G network for maximum security and convenience.

GateLox Electric Gate Lock

Adds an extra measure of security to your swing gate installation and helps prevent the gate(s) from being forced open. Features convenient manual override facility.



FIGURE 33



Connect with us on:

 facebook.com/CenturionSystems

 YouTube.com/CenturionSystems

 [@askCenturion](https://askCenturion)

Subscribe to the newsletter: www.CentSys.com/Subscribe

Call Centurion Systems (Pty) Ltd • South Africa
Head Office: +27 11 699 2400

Call Technical Support: +27 11 699 2481
from 07h00 to 18h00 (UTC+2)



Doc number: 0.07.A.0263_19022015
ENGLISH

www.CentSys.com