

**SECTOR
TRAFFIC
BARRIERS
ACCESSORY**

Company Profile



1986



1990



1995



1999



**CENTSYS
today**

**In-house
R & D
development
team**



**Manufacture to
international
quality standard
ISO 9001:2008**



**100%
testing of
products**



**Competent
after-sales
technical support**



**Sales and support throughout
Southern Africa and over
50 countries worldwide**

CENTURION SYSTEMS (Pty) Ltd reserves the right to make changes to the products described in this manual without notice and without obligation of CENTURION SYSTEMS (Pty) Ltd to notify any persons of any such revisions or changes. Additionally, CENTURION SYSTEMS (Pty) Ltd makes no representations or warranties with respect to this manual. No part of this document may be copied, stored in a retrieval system or transmitted in any form or by any means electronic, mechanical, optical or photographic, without the express prior written consent of CENTURION SYSTEMS (Pty) Ltd



Contents



IMPORTANT SAFETY INSTRUCTIONS

page 1

1. General Description page 2
2. Icons Used in this Manual page 3
3. Product Identification page 4
4. Required Tools page 5
5. Site Considerations page 5
6. Installation Procedure page 6
 - Configurations page 6
 - Recommended Vehicle Clearance page 7
 - Drilling the Holes page 8
 - Fitting the **Jack-knife Assembly** to the Pole page 9
 - Adjustments page 11
7. Installation Handover Page 11

**Safety
FIRST**

IMPORTANT Safety Instructions

ATTENTION

To ensure the safety of people, it is important that you read all the following instructions. Incorrect installation or incorrect use of the product could cause serious harm to people.



The installer, being either professional or DIY, is the last person on the site who can ensure that the operator is safely installed, and that the whole system can be operated safely.

Warnings for the installer

CAREFULLY READ AND FOLLOW ALL INSTRUCTIONS.

Before beginning to install the product;

- Installation of the **Jack-knife Assembly** must be carried out by a suitably qualified person
- Do not in any way modify the components
- Do not leave packing materials (plastic, polystyrene, etc.) within reach of children as such materials are potential sources of danger
- CENTSYS does not accept any liability caused by improper use of the product, or for use other than that for which it was intended
- This product was designed and built strictly for the use indicated in this documentation. Any other use, not expressly indicated here, could compromise the service life/operation of the product and/or be a source of danger
- The installer must explain the operation of the **Jack-knife Assembly** and any safety hazards to the end-user. Refer to the 'Installation Handover' section
- **Anything not expressly specified in these instructions is not permitted**

1. General description



FIGURE 1

Certain installations may require that the boom pole of the SECTOR barrier bend at an angle to allow sufficient clearance when raising. This could be due to a particularly low ceiling, for example or a similar hindrance which has diminished overhead space.

The SECTOR **Jack-knife Assembly** can be fitted to an existing boom pole which will allow the arm to bend at an angle by means of a metallic 'knuckle', and to become level again when in the lowered position.

The **Jack-knife Assembly** is easy to install and adjust and is suitable for all SECTOR barrier pole lengths. This instruction manual will guide the user through the installation process and provide graphic representation where applicable.

2. Icons used in this Manual



This icon indicates tips and other information that could be useful during the installation.



This icon denotes variations and other aspects that should be considered during installation.



This icon indicates warning, caution or attention! Please take special note of critical aspects that **MUST** be adhered to in order to prevent injury.

3. Product Identification

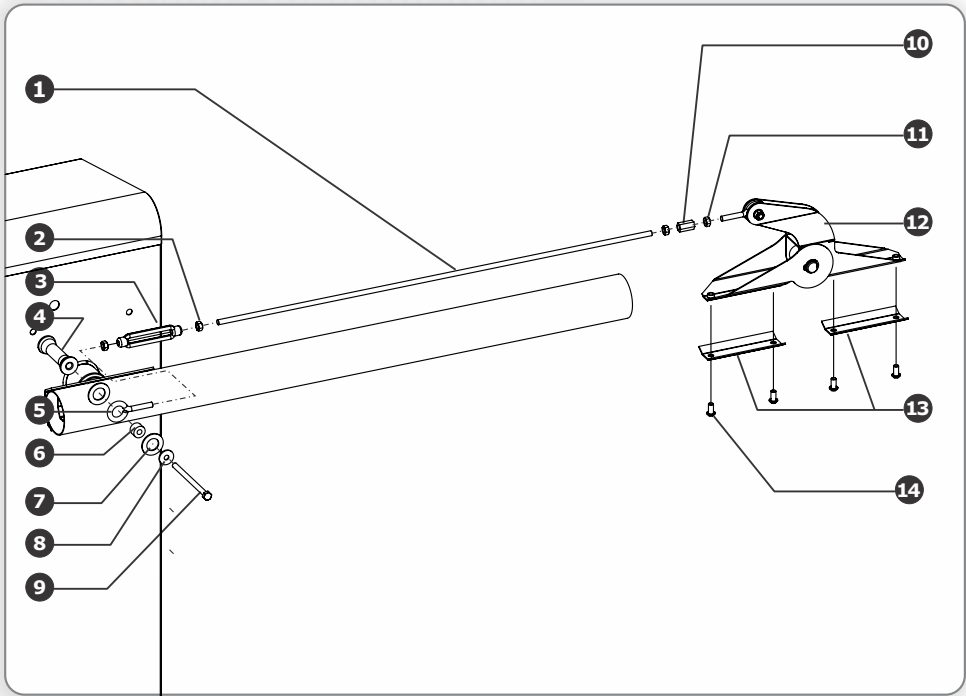

FIGURE. 2. JACK-KNIFE ASSEMBLY

1. M8 threaded bar
2. M8 nut
3. M8 turnbuckle
4. Mounting
5. Eye bolt Left Hand M8 x 60
6. Eye bolt bush
7. M20 (21 x 37 x 2) washer
8. M8 (8.4 x 25 x 2) washer
9. M8 x 120 Taptite screw
10. Joiner M8 x 25
11. M8 nut
12. **Jack-knife Assembly**
13. Support plate
14. Button-head cap screw M8 x 16

4. Required tools

- Spanner – 13mm
- Hammer
- Electric drilling machine
- Steel drill bits – 8.5mm
- Spirit level
- Measuring tape
- Hacksaw
- Marking pen/pencil
- Allen key set

5. Site considerations

General considerations for the installation

The barrier pole must be cut into two pieces using a hacksaw; the length of the individual pieces will be dependent upon the height of the ceiling – the lower the ceiling, the shorter the inner pole will be. It is not necessary to cut the pole into equal lengths.

6. Installation procedure

Configurations



The SECTOR traffic barrier is available in two configurations, namely Left-hand and Right-hand orientation. To successfully fit the **Jack-knife Assembly**, it is necessary to first determine the orientation of the barrier it is to be installed on.

A Left-hand barrier is defined as a unit installed on the left-hand side of the road from which the vehicle approaches. The door always faces oncoming traffic.

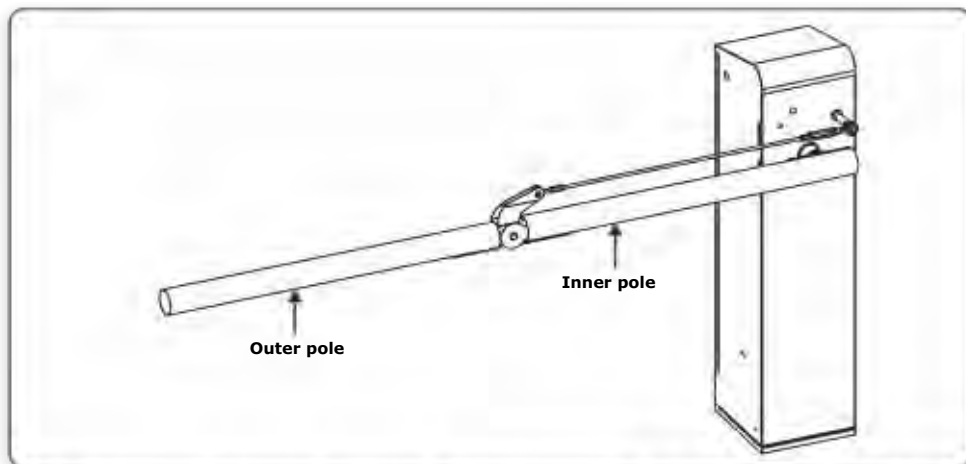

FIGURE 3

A Right-hand barrier is defined as a unit installed on the right-hand side of the road from which the traffic approaches. The door always faces oncoming traffic.

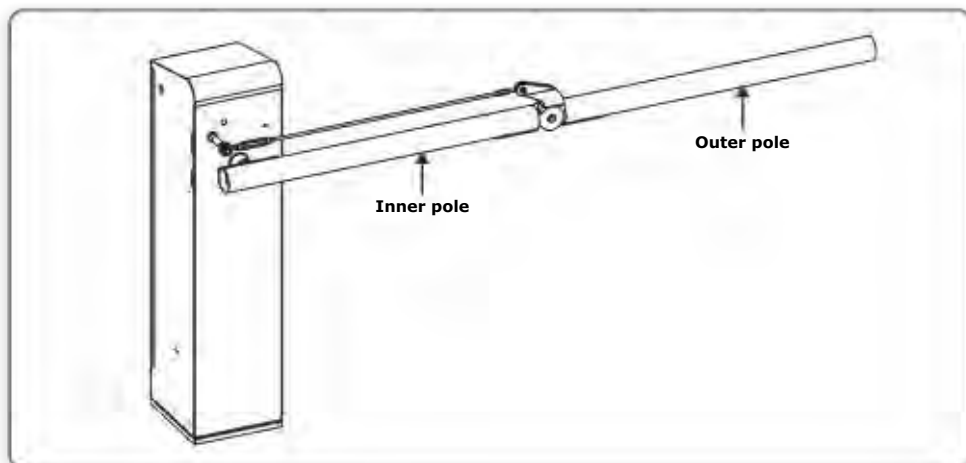

FIGURE 4

Recommended vehicle clearance

Figure 5 shows the recommended minimum clearance when fitting the SECTOR Jack-knife Assembly, giving an indication of the length that the inner pole should be cut to

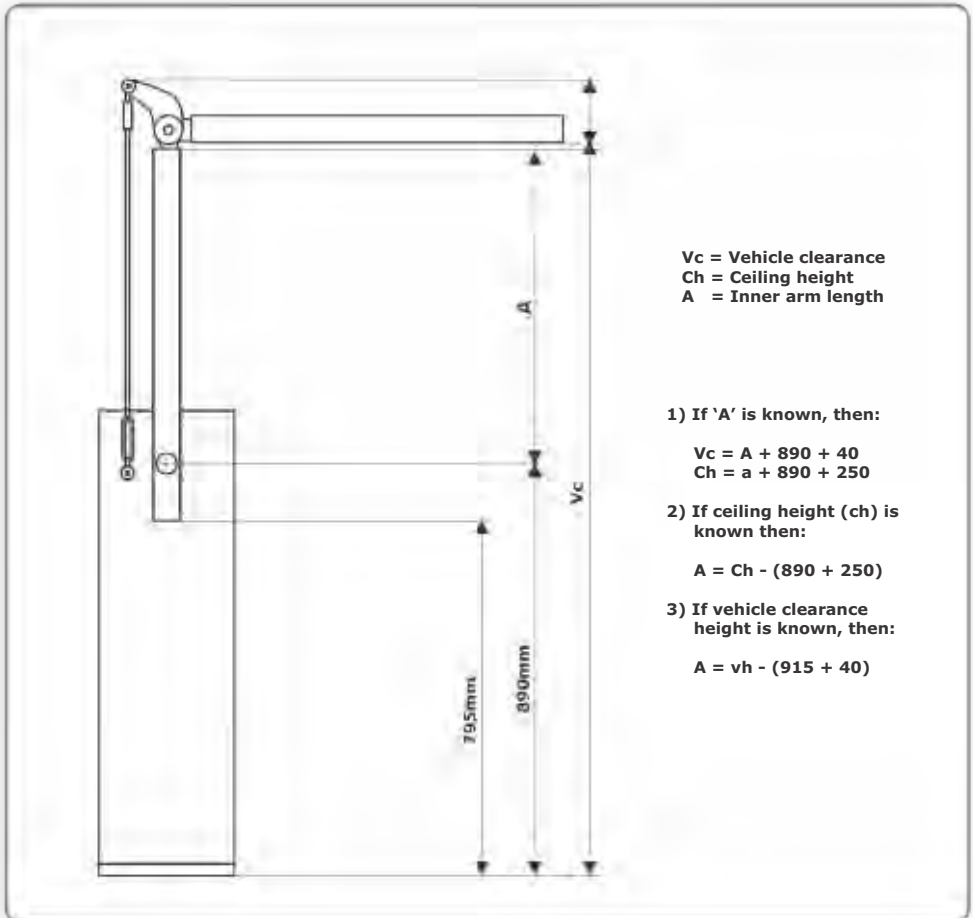

FIGURE 5

Drilling the holes

Existing installation

1. Determine the orientation of the traffic barrier.
2. Identify where you want to mount the **Jack-knife Assembly** and cut the boom pole into two pieces.
3. On the inner pole (pole that is mounted onto the barrier housing), mark two holes, following the measurements as shown in Figure 6.

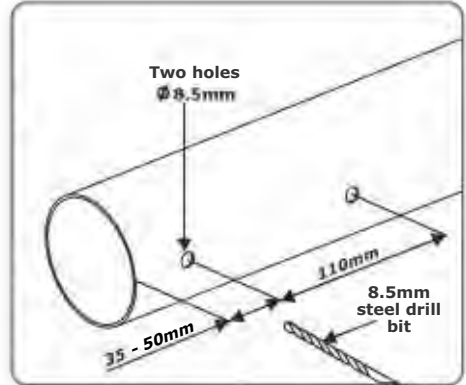

FIGURE 6



The boom pole should be in the lowered position when you mark the location of the two holes.

The holes must always be at the bottom and at 90° to the barrier mounting holes

4. Remove the pole from the barrier and drill the holes.

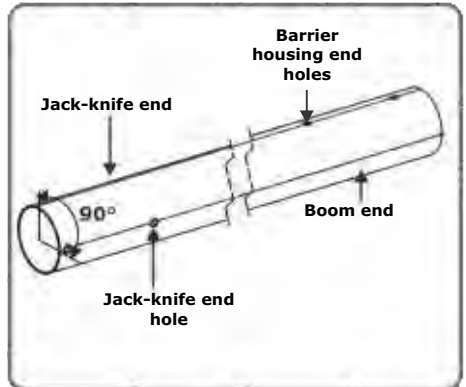

FIGURE 7. INNER POLE

Ensure that the **Jack-knife Assembly** fixing holes are drilled at an angle of 90° to the holes for the coupler, as drilling them at a much greater or lesser angle could result in the outer pole leaning excessively to one side when raising.



5. Drill holes in the outer pole following the measurements shown in Figure 8.

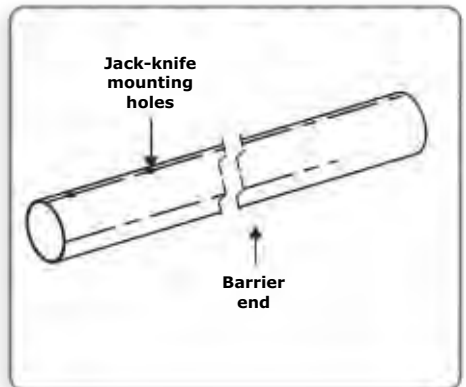

FIGURE 8. OUTER POLE

New pole

1. Identify the position on the pole where you want to mount the **Jack-knife Assembly** and cut the pole into two pieces.
2. Measure and drill two holes following measurements shown in Figure 9 and mount the pole onto the traffic barrier to the boom coupling as per standard boom replacement procedure.
3. Follow the same process of measuring, marking and drilling as per the method used on an existing installation.

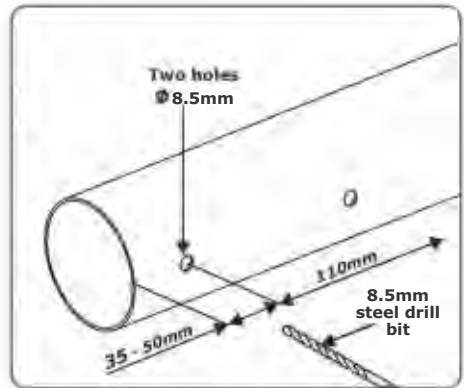

FIGURE 9

Fitting the Jack-knife Assembly to the pole

1. With the threaded eye bolt facing the barrier as shown in Figure 10, slide and align the **Jack-knife Assembly** onto the inner pole.
2. Secure the **Jack-knife Assembly** using the fixing brackets and four button-head screws provided. Use an Allen key to tighten the button heads.

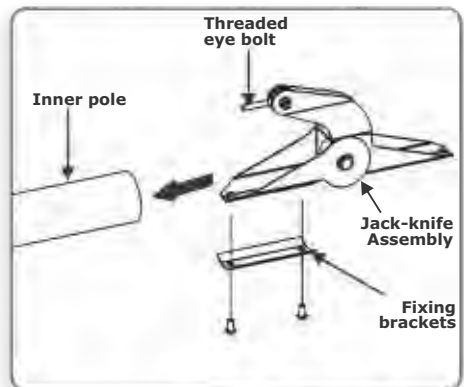

FIGURE 10

3. Slide the outer pole onto the **Jack-knife Assembly**, align the holes and secure using the fixing brackets and four button-head screws provided.

Use an Allen key to tighten the button heads.

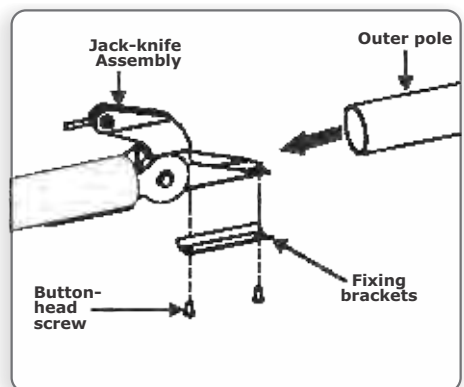

FIGURE 11

4. Assemble the pivot pillar components onto the barrier as shown in Figure 12.

Holes are provided in the SECTOR housing to accommodate both left- and right-hand orientations.



The M8x120 mounting screws supplied with the pivot assembly are Taptite screws, meaning that they will cut their own thread in the holes as they are screwed in.

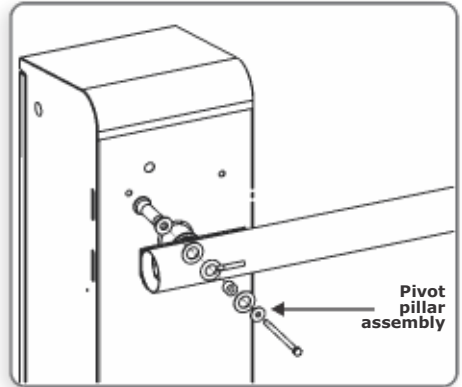

FIGURE 12

5. Using a hacksaw, cut the threaded linkage arm to the necessary length - which will correspond with the length of the boom arm - and assemble the linkage arm and link it to the **Jack-knife Assembly** first as per Figure 13.
6. To accomplish this, remove the nut from the Jack-knife linkage (pictured), adjust the hexagonal link to the necessary position and fit the linkage arm to the **Jack-knife Assembly**. Secure with the nut provided.
7. The panel can now be adjusted to face the most favourable angle.

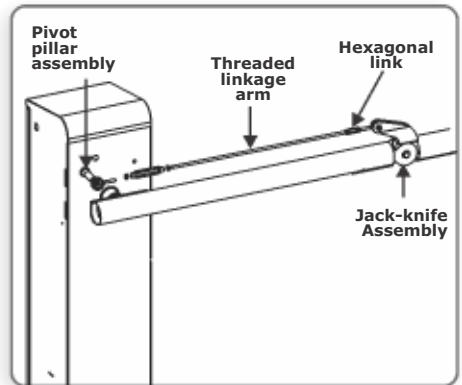

FIGURE 13

8. Fit the other end of the arm to the adjustable link connected to the pivot pillar.



Ensure that the linkage arm and barrier arm are perfectly parallel, as failing to do so may result in the SECTOR gearbox being unnecessarily loaded.

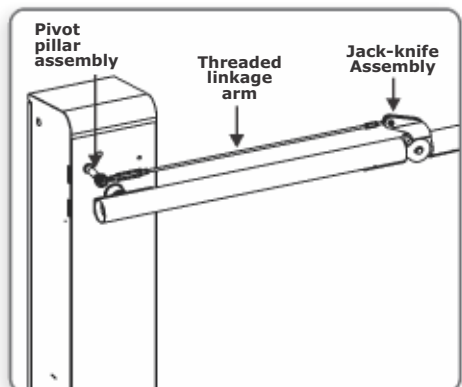

FIGURE 14

Adjustments

1. The barrier pole can now be adjusted using the turnbuckle connected to the pivot pillar. Turning the link in a clockwise direction will result in the outer arm raising, while turning it anti-clockwise will cause it to lower. Once optimal alignment of the barrier pole is obtained, the turnbuckle can be locked in place using the nut provided.

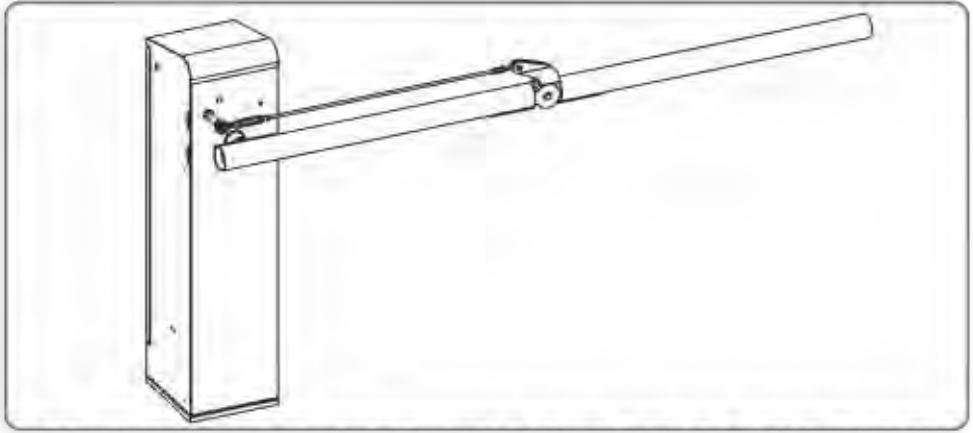

FIGURE 15

2. Test the operation of the barrier, ensuring that the outer pole does not droop excessively nor foul against the ceiling. An angle of approximately 90° should be present between the inner and outer poles.

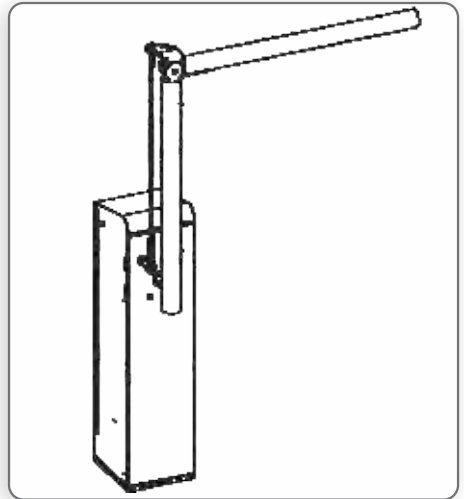

FIGURE 16

7. Installation Handover

Once the **Jack-knife Assembly** has been successfully installed and its operation tested, it is important that the operation and safety considerations are explained to the end-user.

Notes

Notes

Lined area for writing notes.





 facebook.com/CenturionSystems

 YouTube.com/CenturionSystems

 [@askCentSys](https://twitter.com/askCentSys)

Subscribe to the newsletter: www.CentSys.com.au/Subscribe

Call Centurion Systems (Pty) Ltd. South Africa
Head Office: +27 11 699 2400

Call Technical Support: +27 11 699 2481
from 07h00 to 18h00 (GMT+2)



0.07.B.0045_27032014

www.CentSys.com.au