



SECTOR™



**SECTOR
TRAFFIC
BARRIER
ACCESSORIES**

Company Profile



1986



1990



1995



1999



Centurion Systems
today

**In-house
R & D
development
team**



**Manufacture to
international
quality standard
ISO 9001:2008**



**100%
testing of
products**



**Competent
after-sales
technical support**

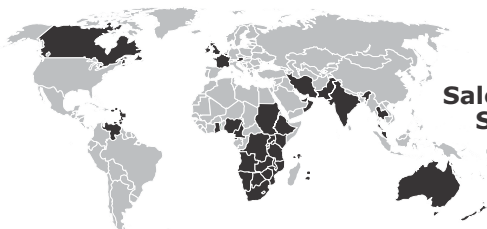

**Sales and support throughout
Southern Africa and over
50 countries worldwide**

CENTURION SYSTEMS (Pty) Ltd. reserves the right to make changes to the products described in this manual without notice and without obligation of CENTURION SYSTEMS (Pty) Ltd. to notify any persons of any such revisions or changes. Additionally, CENTURION SYSTEMS (Pty) Ltd. makes no representations or warranties with respect to this manual. No part of this document may be copied, stored in a retrieval system or transmitted in any form or by any means electronic, mechanical, optical or photographic, without the express prior written consent of CENTURION SYSTEMS (Pty) Ltd.

Contents



IMPORTANT SAFETY INSTRUCTIONS

page 1

1. General description page 3
2. Icons used page 3
3. Product identification page 4
4. Required tools page 4
5. Site consideration page 5
6. SECTOR Breakaway Coupler Installation page 6
7. Boom pole replacement page 11
8. Wiring diagram for a SECTOR Breakaway Coupler page 13
9. Installation handover page 14

**Safety
FIRST**

IMPORTANT Safety Instructions

ATTENTION

To ensure the safety of people, it is important that you read all the following instructions. Incorrect installation or incorrect use of the product could cause serious harm to people.



The installer, being either professional or DIY, is the last person on the site who can ensure that the operator is safely installed, and that the whole system can be operated safely.

Warnings for the installer

CAREFULLY READ AND FOLLOW ALL INSTRUCTIONS.

Before beginning to install the product;

- Make sure that the barrier is in the raised position
- Switch off mains supply to the barrier
- Isolate the battery supply by unplugging the battery connector on the controller
- Installation of the SECTOR Breakaway Coupler must be carried out by a suitably qualified person
- Prior to installing the SECTOR Breakaway Coupler, please ensure that the area where the boom pole will swing away, in the event that it is dislodged, is clear of people and property, and that a stop is fitted to prevent the boom pole swinging further than 90°
- Do not in any way modify the components
- Do not leave packing materials (plastic, polystyrene, etc.) within reach of children as such materials are potential sources of danger
- Centurion Systems does not accept any liability caused by improper use of the product, or for use other than that for which it was intended
- This product was designed and built strictly for the use indicated in this documentation. Any other use, not expressly indicated here, could compromise the service life/operation of the product and/or be a source of danger
- The installer must explain the operation of the SECTOR Breakaway Coupler and any safety hazards to the end user – refer to section "Installation Handover"
- **Anything not expressly specified in these instructions is not permitted.**



WARNING



**Keep fingers and loose clothing clear of the
SECTOR Breakaway Coupler**



1. General description

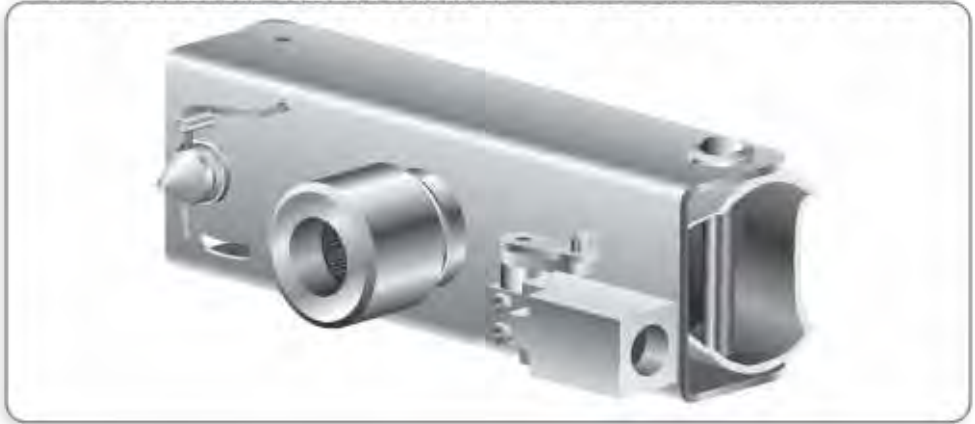

FIGURE 1

The SECTOR Breakaway Coupler has been designed to allow the boom pole to swing away to the side if struck by a vehicle and reduce the damage that can be caused to the pole.

The SECTOR Breakaway Coupler consists of two main parts, the main body which couples to the output shaft of the barrier and the breakaway coupler sleeve, which hinges to the main body at the back. It uses an effective clipping mechanism to lock the coupler sleeve to the main body. Applying a sideways force unclips the coupler allowing the pole to swing to the side away from the roadway, in the direction of normal traffic flow.

The SECTOR Breakaway Coupler incorporates a micro-switch which activates the moment the coupler unclips and the pole swings to the side. The switch is connected to the emergency stop input on the controller to prevent the SECTOR barrier from being operated.

Having hinged to the side, the pole can be re-engaged for operation by simply swinging it back and pressing it into the coupler.

The SECTOR Breakaway Coupler is retro-fittable on the SECTOR range of barriers. The SECTOR Breakaway Coupler is manufactured from mild steel with ultra-seal corrosion protection.

2. Icons used in this manual



This icon indicates tips and other information that could be useful during the installation.



This icon denotes variations and other aspects that should be considered during installation.



This icon indicates warning, caution or attention! Please take special note of critical aspects that **MUST** be adhered to in order to prevent injury.

3. Product identification

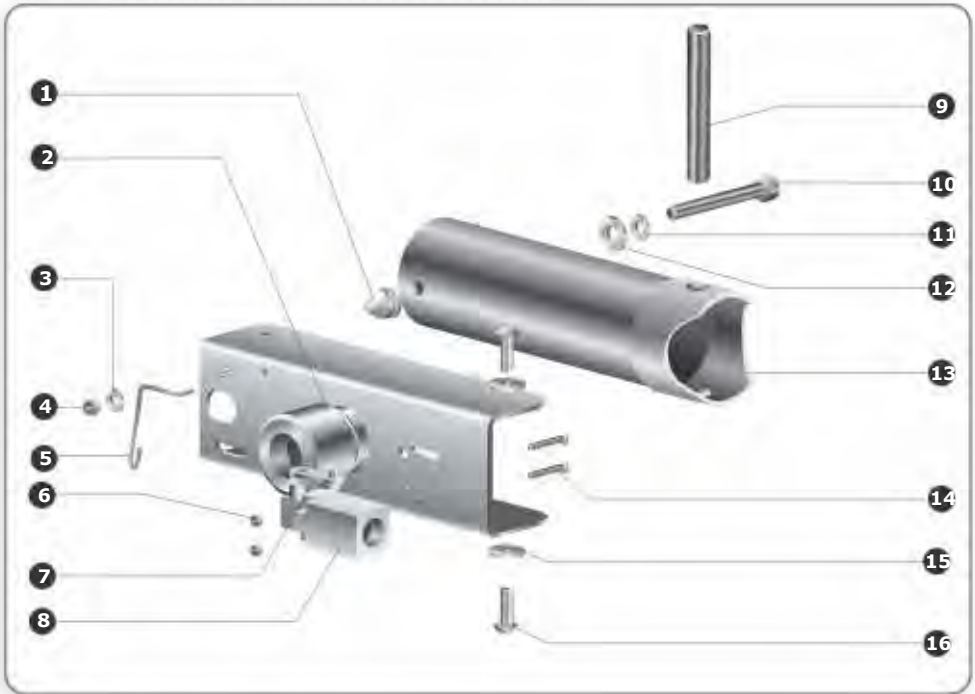

FIGURE 2

- | | |
|---------------------------------------|---|
| 1. Profiled nut | 9. Hinge pin |
| 2. Boom support plate welded assembly | 10. Cap screw M8 x 90 |
| 3. M8 heavy duty flat washer HDG | 11. Washer spring galvanised M8 |
| 4. M6 nyloc nut | 12. M6 heavy duty flat washer HDG |
| 5. Spring clip | 13. Boom sleeve |
| 6. M4 nyloc nut | 14. Cheese head screw M4 x 30 |
| 7. Limit actuator | 15. Washer flat head galvanised M8 x 25 x 2 |
| 8. Omron D4D-1120N | 16. Hex socket button head M8 x 25 |

4. Required tools

- Drilling equipment
- 8.5mm drill bit
- Allen key – 6 mm, 8mm
- Spanner – 17mm
- Centre punch
- Ball-peen hammer
- Marking pencil

5. Site considerations



When installing a traffic barrier, which will utilise a SECTOR Breakaway Coupler, it is important to consider the direction in which the boom pole will swing in the event of a breakaway.

Boom in lowered position

The SECTOR Breakaway Coupler is designed to open 90° only, in the direction of normal traffic flow. Depending on the speed at which the breakaway coupler is forced open, the boom pole may extend beyond 90°, in which case it will be necessary for a stop to be installed to ensure that the boom pole will not go beyond the 90° angle.

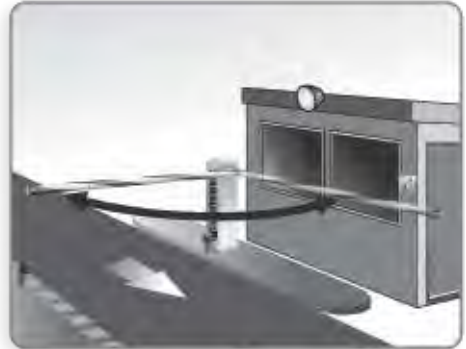

FIGURE 3



A stop must be installed.

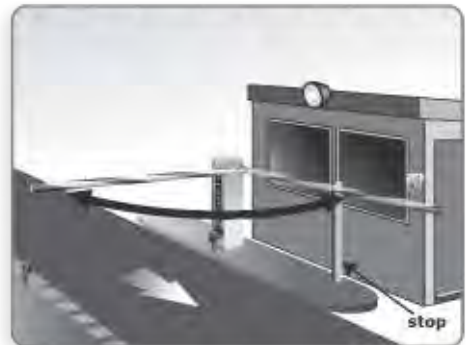

FIGURE 4

Boom in raised position



Should the boom pole be knocked out of its coupling while the pole is being raised or in the raised position, the boom pole will fall uncontrolled from the raised position.

It is advisable to keep this area free from obstacles that may be damaged, or personnel that could sustain serious



FIGURE 5

6. SECTOR Breakaway Coupler installation

- Make sure that the the mains supply to the barrier has been switched off
- Ensure that the battery supply has been isolated by unplugging the connector on the controller
- Ensure that the barrier is in vertical position



1. Before mounting the SECTOR Breakaway Coupler to barrier, wire limit switch to controller.

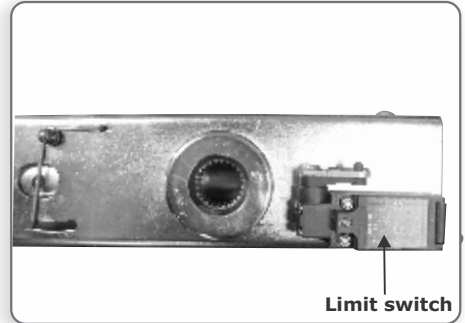

FIGURE 6

2. Unscrew limit switch cover. Terminate two core cable onto terminals marked NC (normally closed). A cable gland must be used to seal cable entry.

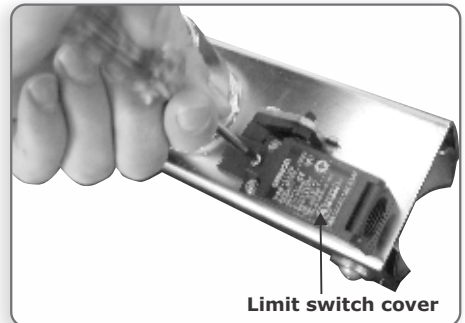

FIGURE 7

3. Route cable into housing. Use cable gland to seal entry. Slide SECTOR Breakaway Coupler onto barrier shaft ensuring that it is perfectly vertical.

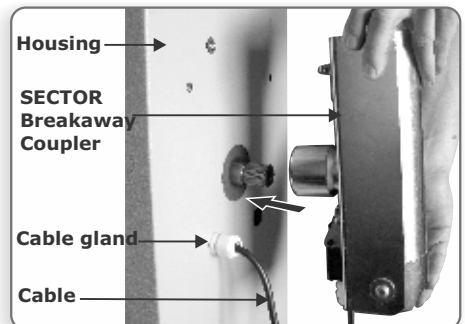

FIGURE 8

4. Leave a loop in the cable between the limit switch and the barrier housing.

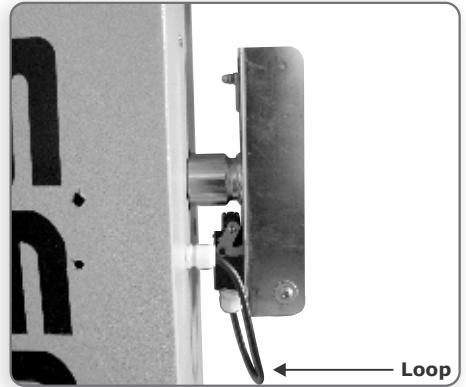

FIGURE 9

5. Secure the SECTOR Breakaway Coupler with the cap screw provided and tighten (use 8mm allen key).

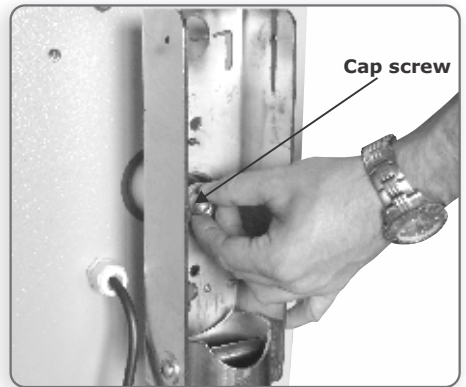

FIGURE 10

6. Slide the boom pole onto the SECTOR Breakaway Coupler sleeve until it reaches the end.

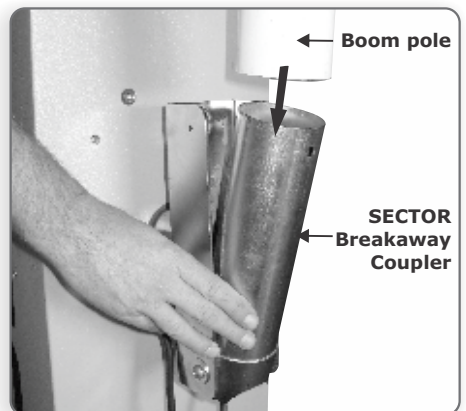

FIGURE 11

- 7. Use the hole in the SECTOR Breakaway Coupler as a template for marking the coupler pin mounting hole – refer to image.

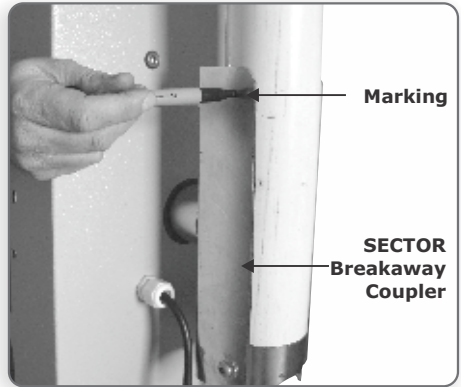

FIGURE 12

- 8. Mark pole on both sides making sure that the pole is not twisted in the process.

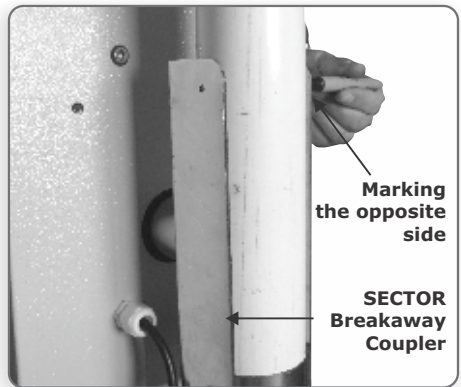

FIGURE 13

- 9. Slide the pole out so that the mark is away from the SECTOR Breakaway Coupler and the hole can be drilled.

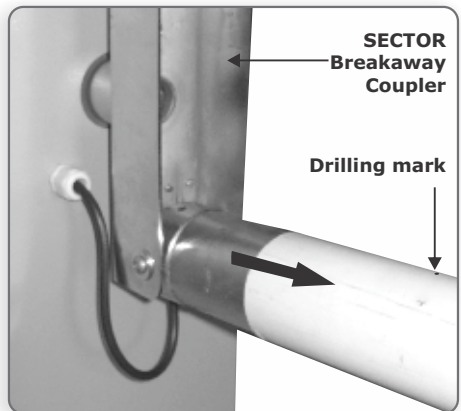

FIGURE 14

10. Use an 8.5mm drill bit, drill holes as prepared.

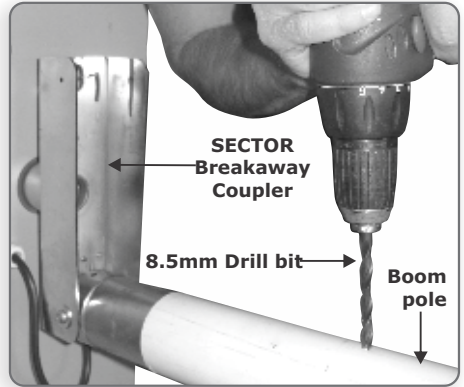

FIGURE 15

11. Slide pole fully back onto coupler sleeve and twist pole through 90° so that hole lines up with coupler pin hole in the SECTOR Breakaway Coupler sleeve.

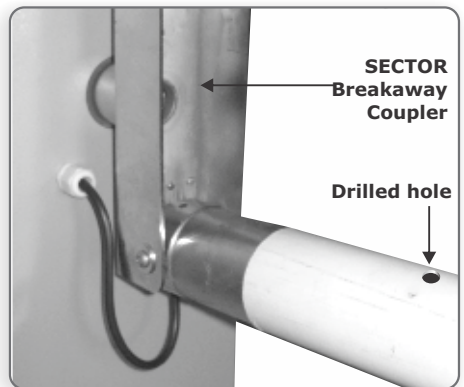

FIGURE 16

12. Insert the coupler pin (cap screw) as shown.

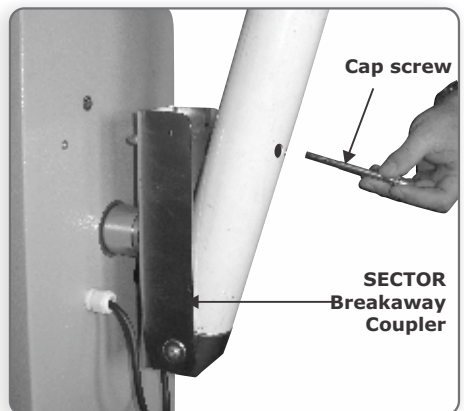

FIGURE 17

13. Fit the spring washer and profiled nut provided and tighten using 6mm allen key and 17mm spanner.

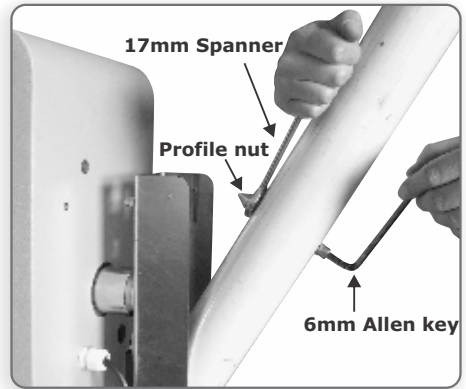

FIGURE 18

14. Hinge the boom pole back into the main body of the SECTOR Breakaway Coupler and clip into position.

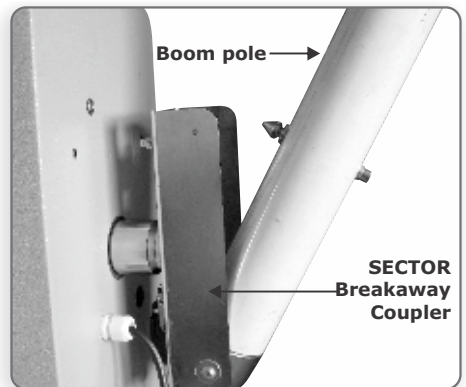

FIGURE 19

15. The boom pole must be securely held by the locking clip as shown.

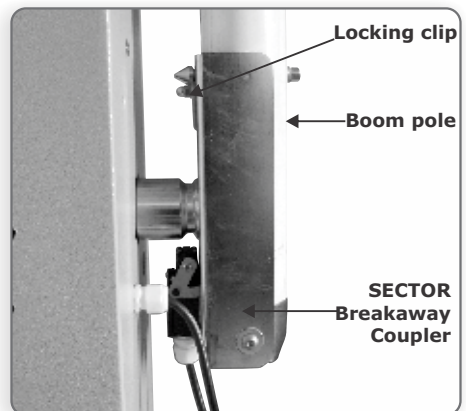

FIGURE 20

7. Boom pole replacement

Should it be necessary to remove the boom pole for whatever reason, follow these instructions.

WARNING!

Ensure that the boom pole is in the raised position and the counterbalance spring de-energised



1. Push the pole away from the SECTOR Breakaway Coupler until it unclips.

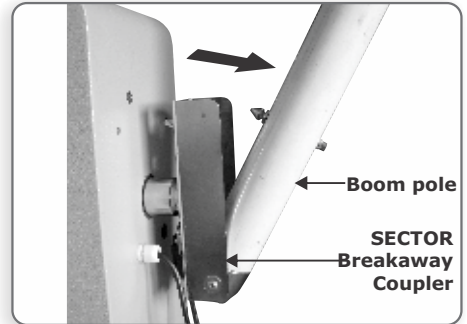

FIGURE 21

2. Loosen the profile nut using a 17mm spanner and 8mm allen key as shown.

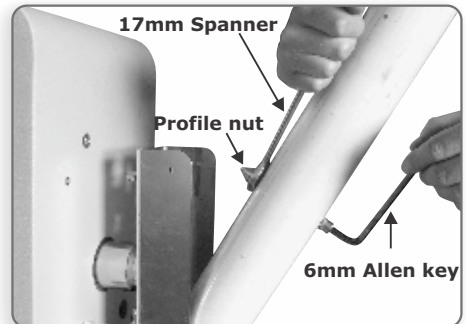

FIGURE 22

3. Remove the hinge pin.

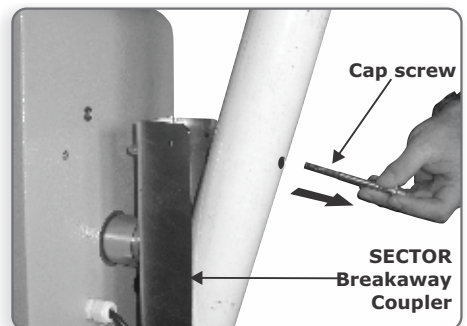

FIGURE 23

4. Slide the pole off the coupler sleeve.

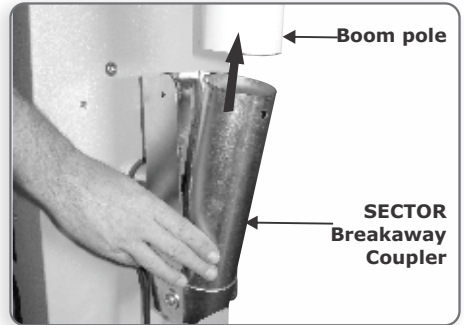

FIGURE 24

5. To fit the new boom pole, refer to the installation section points 8 to 17.

8. Wiring diagram for a SECTOR Breakaway Coupler

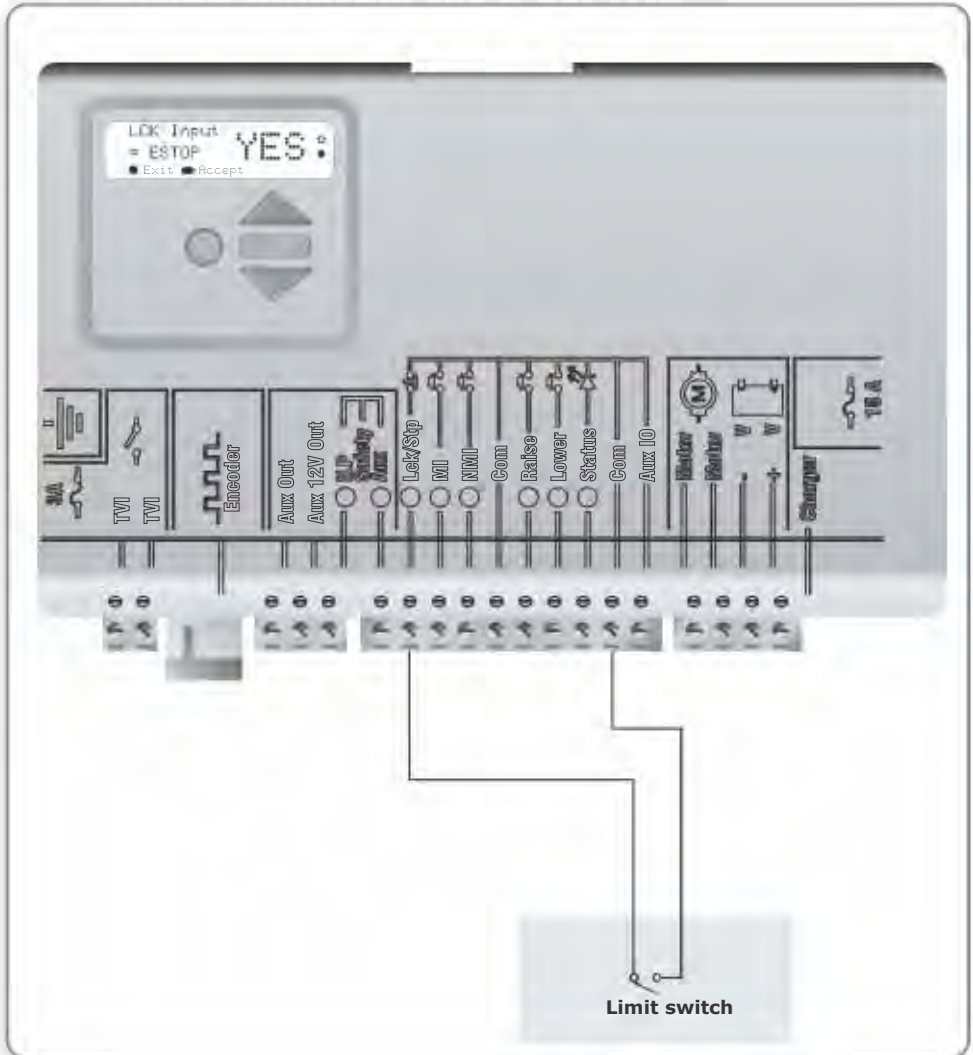

FIGURE 25

- Wire the normally closed contacts of the limit to the Lck/Stp and Com inputs on the controller
- Configure the control card so that the Lck/Stp input behaves as an Emergency Stop
 - Setup menu level two, sub-level four
 - Select Lck input as ESTOP (Emergency Stop)

9. Installation handover

Once the SECTOR Breakaway Coupler has been successfully installed and its operation tested, it is important for the operation and safety considerations to be explained to the end user of the system.

Notes

A series of horizontal dotted lines for taking notes.



Notes



A series of horizontal dotted lines for writing notes.



Notes

Notes

Lined area for writing notes.





 facebook.com/CenturionSystems

 YouTube.com/CenturionSystems

 [@askCentSys](https://twitter.com/askCentSys)

Subscribe to the newsletter: www.CentSys.com.au/Subscribe

Call Centurion Systems (Pty) Ltd. South Africa
Head Office: +27 11 699 2400

Call Technical Support: +27 11 699 2481
from 07h00 to 18h00 (GMT+2)



0.07.B.0105_31032014

www.CentSys.com.au