

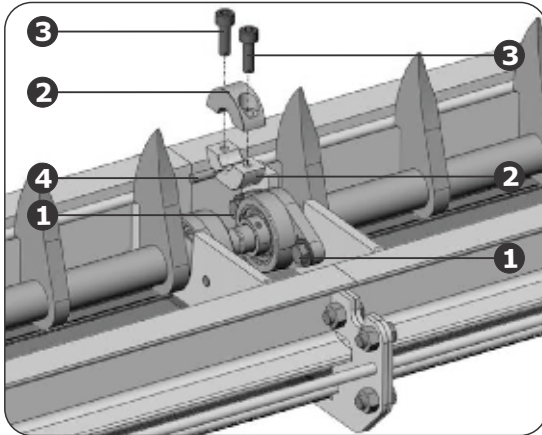

CENTURION

CLAWS shaft coupler



1. M10 bolts and washers
2. Shaft split coupler
3. M10 cap screws
4. Dowel pin

Fitting the CLAWS shaft coupler

When joining two or more CLAWS modules or connecting a CLAWS module to a drive module, it is necessary to fit a shaft coupler. The procedure described below contains steps and information that are imperative to a safe and reliable CLAWS installation and as such must be adhered to as closely as possible.

Where reference is made to a specific part or component, a number is given in brackets next to the description of the part, and this number corresponds to a number on the sketch above.

1. Hand-tighten the M10 bolts (1) securing the flanged bearings to the sub-frame.
2. Assemble the split coupler (2) around the shafts with the $\varnothing 8\text{mm}$ dowel pin (4) placed in the slot of the bottom coupler, then fit the M10 cap screws and tighten them by hand. Ensure that the coupler is centred between the flanged bearings.
3. Tighten the coupler M10 cap screws (3) in sequence; in other words, for every number of turns applied to one screw, the same number of turns (approximately) must be applied to the second screw. Failure to adhere to this procedure will result in one screw pulling the other skew and the coupler's thread stripping.



It is useful to use a torque wrench when tightening the coupler around the shaft. CENTURION recommends tightening the cap screws to 65Nm

4. Finally, tighten the M10 bolts securing the flanged bearings to the sub-frame using a 17mm spanner.



Do not over-tighten the bolts, as doing so will cause the thread to strip!