



UNDERGROUND SWING GATE OPERATOR

Company Profile



1986



1990



1995



1999



Centurion Systems
Today

**In-house
R & D
development
team**



**Manufacture to
international
quality standard
ISO 9001:2008**



**100%
testing of
products**



**Competent
after-sales
technical support**



**Sales and support throughout
Southern Africa and over
50 countries worldwide**

CENTURION SYSTEMS (Pty) Ltd. reserves the right to make changes to the products described in this manual without notice and without obligation of CENTURION SYSTEMS (Pty) Ltd. to notify any persons of any such revisions or changes. Additionally, CENTURION SYSTEMS (Pty) Ltd. makes no representations or warranties with respect to this manual.

No part of this document may be copied, stored in a retrieval system or transmitted in any form or by any means electronic, mechanical, optical or photographic, without the express prior written consent of CENTURION SYSTEMS (Pty) Ltd.

Contents



Mechanical setup	page 1
Electrical setup	page 2
Commissioning and handover	page 2



IMPORTANT SAFETY INSTRUCTIONS	page 3
-------------------------------	--------

1. Declaration of conformity	page 5
2. General description	page 6
3. Specifications	page 7
Fuse protection	page 9
4. Icons used in this manual	page 9
5. Product identification	page 10
6. Required tools and equipment	page 11
7. Preparation of site	page 12
8. Cabling requirements	page 13
9. Operator installation	page 15
10. Electrical setup	page 23
11. Wiring diagram for safety beams	page 25
12. Wiring diagram for other accessories	page 26
13. Wiring diagram for motors and open limits	page 27
14. Controller features	page 32
15. Description of terminal functions	page 35
16. Diagnostics	page 37
Diagnostic LEDs	page 37
Gate status LED	page 38
17. Manual release operation	page 39
18. Installation handover	page 40



Mechanical setup

These abbreviated instructions are for the experienced installer who needs a checklist to get a standard installation up and running in the minimum of time.

Detailed installation features and functions are referred to later in this manual.



Gather required tools and equipment page 11



Heed necessary site considerations page 12



Check cabling requirements page 13



Install foundation box page 15



Install motor and link to gate page 18



Set limit switches and /or fit mechanical endstops page 21

Electrical setup



Mount controller enclosure and connect all wiring page 23



Commissioning and handover



Commission system page 28



Carry out professional handover to client page 40





IMPORTANT Safety Instructions

ATTENTION

To ensure the safety of people, it is important that you read all the following instructions. Incorrect installation or incorrect use of the product could cause serious harm to people. 

The installer, being either professional or DIY, is the last person on the site who can ensure that the operator is safely installed, and that the whole system can be operated safely.

Warnings for the installer

CAREFULLY READ AND FOLLOW ALL INSTRUCTIONS before beginning to install the product.

- All installation, repair, and service work to this product must be carried out by a suitably qualified person
- This appliance is not intended for use by persons (including children) with reduced physical, sensory or mental capabilities, or lack of experience and knowledge, unless they have been given supervision or instruction concerning use of the appliance* by a person responsible for their safety
- Do not activate your gate opener unless you can see it and can determine that its area of travel is clear of people, pets, or other obstructions
- **NO ONE MAY CROSS THE PATH OF A MOVING GATE.** Always keep people and objects away from the gate and its area of travel
- **NEVER LET CHILDREN OPERATE OR PLAY WITH THE GATE CONTROLS**
- Secure all easily accessed gate opener controls in order to prevent unauthorized use of the gate
- Do not in any way modify the components of the automated system
- Do not install the equipment in an explosive atmosphere: the presence of flammable gasses or fumes is a serious danger to safety
- Before attempting any work on the system, cut electrical power to the operator and disconnect the batteries
- The mains power supply of the automated system must be fitted with an all-pole switch with contact opening distance of 3mm or greater. Use of a 5A thermal breaker with all-pole circuit break is recommended
- Make sure that an earth leakage circuit breaker with a threshold of 30mA is fitted upstream of the system

- Never short circuit the battery and do not try to recharge the batteries with power supply units other than that supplied with the product, or by Centurion Systems
 - Make sure that the earthing system is correctly constructed, and that all metal parts of the system are suitably earthed
 - Safety devices must be fitted to the installation to guard against mechanical movement risks, such as crushing, dragging and shearing
 - It is recommended that at least one warning indicator light be fitted to every system
 - Always fit the warning signs visibly to the inside and outside of the gate
 - The installer must explain and demonstrate the manual operation of the gate in case of an emergency, and must hand the User Guide over to the user
 - Explain these safety instructions to all persons authorized to use this gate, and be sure that they understand the hazards associated with automated gates
 - Do not leave packing materials (plastic, polystyrene, etc.) within reach of children as such materials are potential sources of danger
 - Dispose of all waste products like packaging materials, worn out batteries, etc. according to local regulations
 - Always check the obstruction detection system, and safety devices for correct operation
 - Centurion Systems does not accept any liability caused by improper use of the product, or for use other than that for which the automated system was intended
 - This product was designed and built strictly for the use indicated in this documentation. Any other use, not expressly indicated here, could compromise the service life/operation of the product and/or be a source of danger
- * Appliance should be product described in manual

WARNING! WARNING! WARNING! WARNING! WARNING!



**KEEP CLEAR!
GATE MAY MOVE AT ANY TIME!**

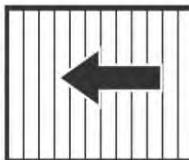

**MOVING GATE CAN CAUSE SERIOUS INJURY OR DEATH!
KEEP CLEAR! GATE MAY MOVE AT ANY TIME!
DO NOT ALLOW CHILDREN TO PLAY IN AREA
OR OPERATE GATE.**

**Safety
FIRST**

1. Declaration of conformity

Manufacturer: Automatismi Benincà spA
Address: Via Capitello, 45 - 36066 Sandrigo (VI) - Italia

Herewith declares that: the operator for hinged gates model DU.IT24N

- is intended to be incorporated into machinery or to be assembled with other machinery to constitute machinery covered by Directive 89/392 EEC, as amended;
- does therefore not in every respect comply with the provisions of this Directive;
- does comply with the provisions of the following other EEC Directives:
Direttiva compatibilità elettromagnetica 89/336/CEE, 93/68/CEE.

and that:

- the following (parts/clauses of) harmonized standards have been applied:

EN 55022, EN 61000-3-2, EN 61000-3-3, EN 50082-1.

And furthermore declares that it is not allowed to put the machinery into service until the machinery into which it is to be incorporated or of which it is to be a component has been found and declared to be in conformity with the provisions of Directive 89/392/EEC and with national implementing legislation, i.e. as a whole, including the machinery referred to in this declaration.



Benincà Luigi, Responsabile legale.

Sandrigo, 10/01/2005.

2. General description

The **IT24, Beninca** is an underground swing gate operator designed for domestic and light-industrial applications where the operator is hidden from view. It is also useful in applications where the gate swings hard up against its side wall leaving absolutely no space to mount a traditional above-the-ground unit.

The operator consists of a high-torque 24V DC motor coupled to a double-stage worm reduction gearbox housed inside a steel foundation box. The assembly is mounted flush with the ground, up against the gate support pillar, directly under the gate hinges. Its output drive arm extends upwards from the operator linking with a drive shoe that is welded to the underside of the gate. The drive arm, drive shoe and operator cover plate are the only parts that are visible. The gate is supported by the operator with the bottom gate hinge removed. Only the top hinge is left to stabilize the top of the gate.

To ensure rigid closing of the gate in the closed position, end-of-travel mechanical endstops must be installed. In addition, if the gate leaf is wider than 2.5m, an electric lock must be fitted, and on any width if maximum security is required.

The internal mechanical limit switches can be used to stop the gates in the open position, the alternative being mechanical endstops.

A Manual Override with key release is incorporated into the drive arm assembly.

The operators are battery driven via the CP77/24V dual motor controller, which supports a host of useful features in addition to providing smooth acceleration of the motors on start-up, safe protection against crushing and critical power failure protection.

Summary of features supported by the CP77/24V controller

- Modes of Operation:
 - Standard only
 - Pedestrian Opening
 - Free-exit Opening
- Autoclose, selectable via ON/OFF switch and closing time adjustable
- Open and closed end-of-travel limits
- Infrared safety beam input for gates when closing
- A status LED output to indicate the gate status remotely
- Solenoid lock drive output with load capacity up to 2A
- Pillar Light Control
- Holiday Lockout
- Battery Low Protection
- Leaf delay – must be ordered with specific plug-in microcontrollers

3. Specifications

Gearbox and DC motor assembly

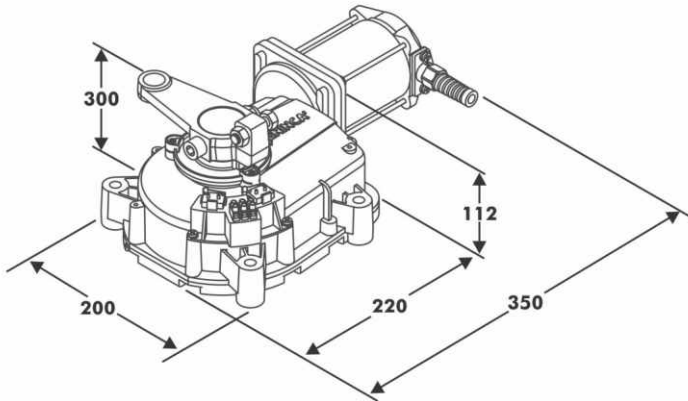

* Output drive arm, mechanical release and drive shoe not shown
All dimensions shown in millimeters

FIGURE 1. GEARBOX AND MOTOR DIMENSIONS

Foundation box

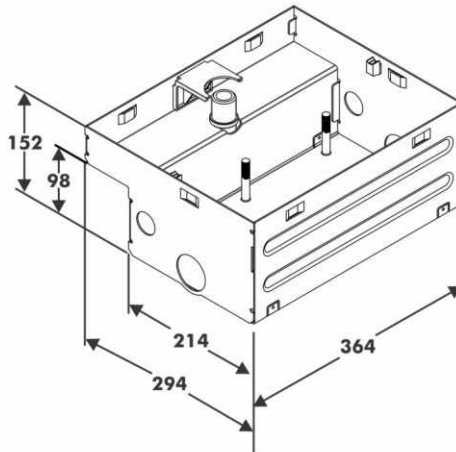

All dimensions shown in millimeters

FIGURE 2. FOUNDATION DIMENSIONS

Technical specifications

Input voltage	220V AC \pm 10%, 50Hz*
Motor voltage	24V DC
Motor power supply	Battery driven (standard capacity - 2 x 7Ah)**
Battery charger*	500mA @ 27.5V DC
Current consumption (mains)	60mA
Current consumption (motor at rated load)	5A
Current consumption (controller and receiver only - standby)	70mA
Operator output torque - maximum	360Nm
Typical gate opening time (90° opening)	15-23 seconds
Operator reversible / irreversible	Irreversible
Manual Override	Key release
Maximum number of operations per day	200
Duty cycle - mains present * ☆	50%
Operations in standby †	
With 7Ah battery	
Half day	26
One day	19
With 40Ah battery	
Half day	155
One day	149
Collision sensing	Electronic
Operating temperature range	-15°C to +50°C
Gearbox housing protection	IP67
Receiver type	External
Mass of unit packed	
Operator	11.6kg
Foundation box	8.6kg
Controller housing	4kg (excludes batteries)
Packaging dimensions	
Operator	350 x 150 x 200mm
Foundation box	400 x 400 x 250mm
Controller housing	480 x 320 x 150mm

* Can operate off a solar supply, consult Centurion Systems for assistance

** Can increase battery capacity for longer standby times

• Based on 25°C ambient temperature and unit not in direct sunlight

☆ Based on an output torque of less than 50% of maximum

† Based on double kit excluding infrared safety beams

Allowable gate mass

Leaf width	2.0m	2.5m	3.0m*	3.5m*	4.0m*
Leaf mass	550kg	500kg	450kg	400kg	350kg

* External electric lock must be fitted

Allowable wind loading

Leaf width	2.0m	2.5m	3.0m	3.5m	4.0m
Maximum wind speed (1.8m high gate, 25% coverage)*	80km/h	65km/h	50km/h	40km/h	35km/h
Maximum wind speed (1.8m high gate, 100% coverage)*	45km/h	35km/h	30km/h	25km/h	20km/h

* Assumes collision sensitivity set to low

Fuse protection

The following protection fuses are provided on the system:

Item	Type	Rating
Main controller		
Master motor circuit	5 x 20mm	20A slow blow
Slave motor circuit	5 x 20mm	20A slow blow
Light circuit	5 x 20mm	3A fast blow
Auxiliary supply	5 x 20mm	3A fast blow
Charger		
Mains input	5 x 20mm	250mA fast blow

4. Icons used in this manual



This icon indicates tips and other information that could be useful during the installation.



This icon indicates warning, caution or attention! Please take special note of critical aspects that **MUST** be adhered to in order to prevent injury.



This icon denotes variations and other aspects that should be considered during installation.

5. Product identification

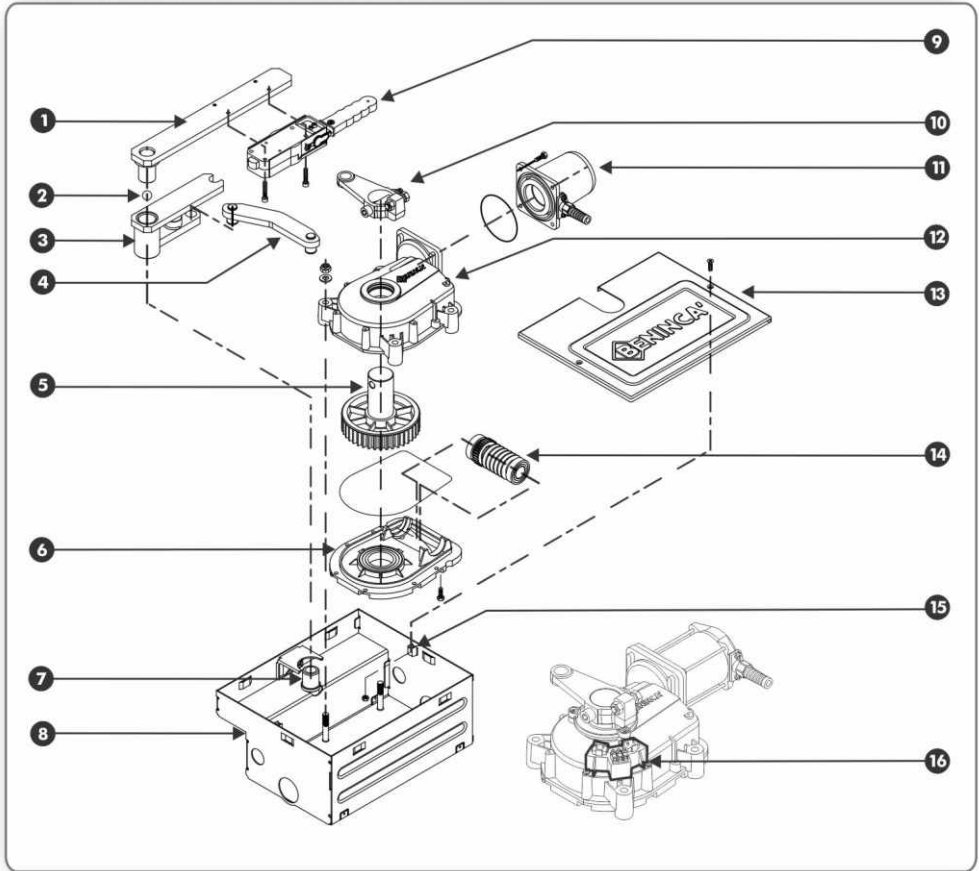

FIGURE 3. PRODUCT IDENTIFICATION

- | | |
|--|--|
| 1. Drive shoe | 9. Manual release mechanism |
| 2. Drive assembly ball bearing | 10. Gearbox drive arm |
| 3. Output drive arm | 11. 24V DC motor and sealing O ring |
| 4. Linkage arm | 12. Gearbox housing |
| 5. Gearbox output shaft and secondary stage wormwheel gear | 13. Foundation box cover plate |
| 6. Gearbox housing bottom cover plate | 14. Secondary stage wormwheel shaft assembly |
| 7. Operator drive safety cap | 15. Foundation box cover fixing bracket |
| 8. Foundation box | 16. End-of-travel limit switches |

6. Required tools and equipment

Allan key – 5mm
Crimping tool and pin lugs
Duct tape
Electric drilling equipment
Hacksaw
Hammer
Measuring tape
Pick
Pliers
Ratchet and extension with a 7mm and 19mm socket
Screwdriver – 3.5mm flat; large star; small star
Side cutters
Spade
Spanner – 17mm and 10mm
Spirit level
Vice grips
Welding equipment

7. Preparation of site

General considerations for the installation

- Always recommend the fitment of additional safety equipment such as safety edges and safety beams, for additional protection against entrapment or other mechanical risks
- Check that no pipes or electrical cables are in the way of the intended installation
- Check that it is possible to mount the foundation box directly beneath the gate hard up against the support pillar noting that the output shaft is vertically below the centerline of the hinges
- Check that it is possible to remove the bottom hinge and allow the gate to be supported by the operator
- Check that there is a sufficient gap between the underside of the gate and the ground to accommodate the operator drive arm and drive shoe with the operator mounted flush with the ground
- Check the fixing of the drive shoe to the underside of the gate. With steel gates the shoe can be welded. With a wooden gate, the shoe will have to be bolted to the gate
- Check for loose, sandy soil as the soil may require a larger concrete foundation to securely support and locate the foundation box
- Check that adequate draining can be provided for the foundation box
- If the swing gate leaf is longer than 2.5mm, ensure that a lock can be fitted
- End-of-travel mechanical endstops must be fitted for the gate in the closed position
- Should any welding or modifications to the gate be required, this should be done prior to the **Beninca** operator being installed

Install the gate operator only if:

- It will not pose a hazard to the public
- There is sufficient clearance to a roadway and/or public thoroughfares
- The installation will meet all municipal and/or local authority requirements once completed
- The gate mass, leaf width, allowable wind loading and application is within the operator specifications (refer to the specification tables)
- The gate is in good working order, meaning:
 - That it swings freely;
 - Does not move on its own if left in any position;
 - Each gate leaf is strong and rigid
- It can be installed to have sufficient clearance between moving parts when opening and closing to reduce the risk of personal injury and entrapment
- Pushbuttons or key switches, when required, can be positioned so that the gate is in line of sight of the operator

8. Cabling requirements

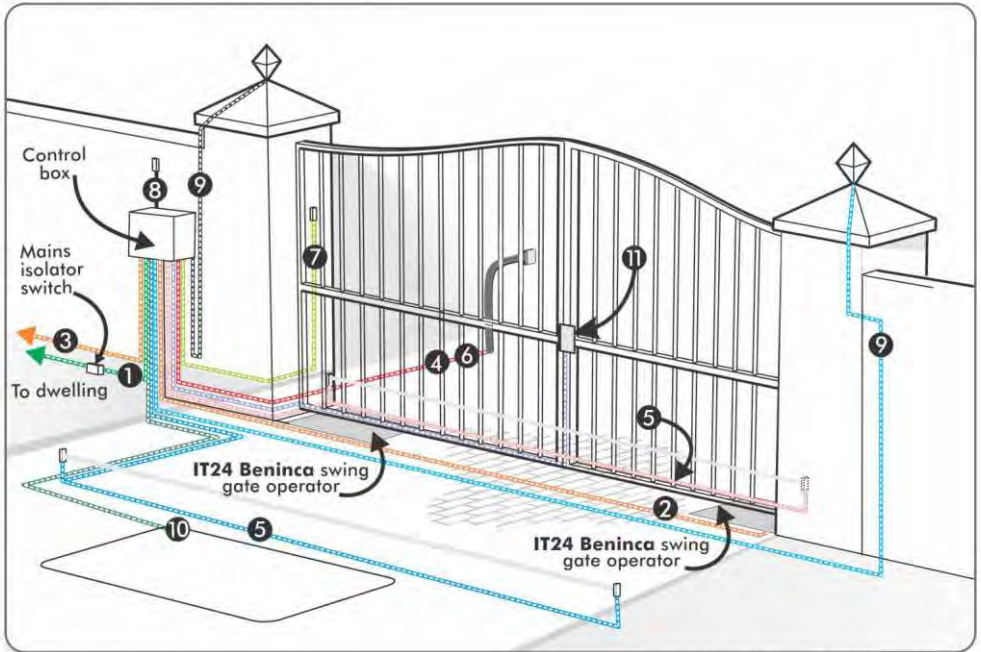

FIGURE 4. CABLING REQUIREMENTS

Legend

- 1a. 220V AC mains cable via double pole mains isolator switch (3 core LNE 1.5mm²* SWA^{*}) or
- 1b. Low voltage cable from transformer (34V secondary @ 800mA) to battery charger (2 core + earth 1.5mm² Norsk[^])
2. Motor cables (2 core + earth 1.5mm², 2 core 0.5mm², multi-stranded)
3. Optional intercom, cable from control box to dwelling (N1) + 6 core @ 0.5mm² multi-stranded)
4. Optional intercom, cable from control box to entry panel (N2) 0.5mm² multi-stranded)
5. Optional infrared safety beams (3 core 0.5mm² multi-stranded)
6. Optional access control device (3 core 0.5mm² multi-stranded Z)
- 7a. Optional pedestrian keyswitch (2 core 0.5mm² multi-stranded) or
- 7b. Optional keypad (3 core 0.5mm² multi-stranded)
8. Optional external radio receiver <(3 core 0.5mm² multi-stranded)
9. Optional pillar lights (3 core LNE SWA^{*}, size according to power requirements)
10. Optional ground loop for free-exit (1 core 0.5mm² multi-stranded - silicone coated C)
11. Optional electric lock (2 core 0.5mm²)



- All cables must be routed in conduit unless underground cable is being used
- Mains isolator must be less than 1m from the operator
- Safety beams are always recommended

- ⌘ Possibly increase cable thickness if pillar lights are to be installed
- ☆ SWA – Steel wire armoured
- ⌘ Type of cable must adhere to municipal bylaws and preferably screened. Screening provides better protection against lightning - earth one end of the screening
- ⌘ Allows for all features such as pedestrian opening, status LED etc., to be operated from the intercom handset inside the dwelling
- ⌘ Number of cores and type of cable could vary depending on brand of access control system being used
- ⌘ For optimum range an external receiver can be mounted on the wall
- ⌘ Consult manufacturer of loop detector for specific details
- ⌘ Number of cores required by the intercom
- ⌘ Number of cores required by the intercom

9. Operator installation

To simplify the installation process, it is recommended that the existing gate is removed from the pillar before proceeding.

Foundation box installation

As the foundation box is liable to fill with water during rainfall, it is critical that an adequate drainage system is prepared. Refer to step 9.



1. Determine the correct position for the foundation box, i.e. **standard** or **inside**.

Standard mounting configurations

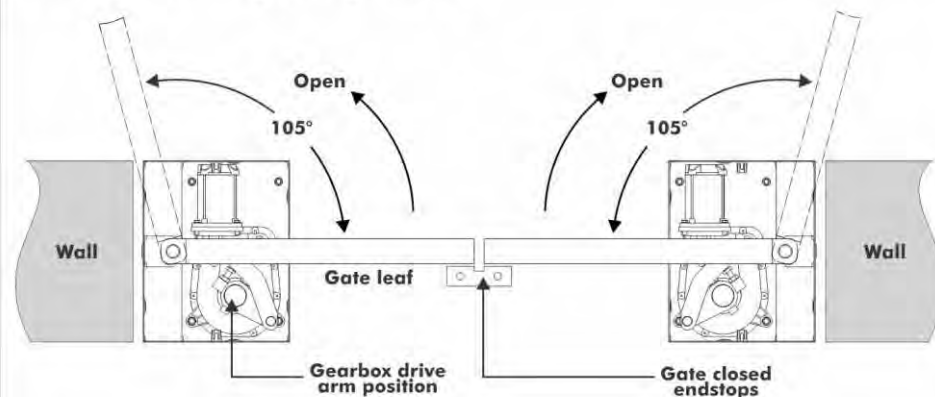

FIGURE 5. STANDARD MOUNTING CONFIGURATIONS

Inside mounting configurations

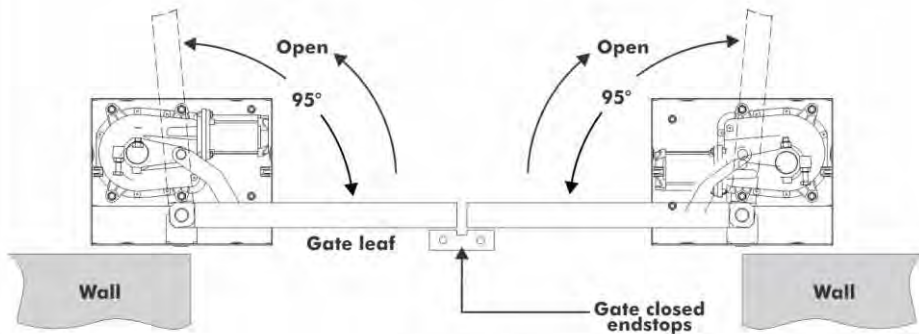

FIGURE 6. INSIDE MOUNTING CONFIGURATIONS

2. Dig a hole for the foundation box - the size of the hole being adequate to securely anchor the foundation box taking into consideration:
- Weight of the gate resting on the foundation box
 - Condition of the soil around the foundation box

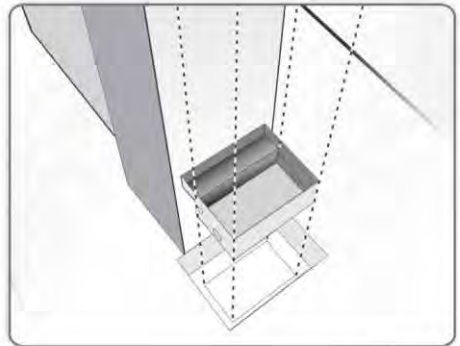

FIGURE 7

3. Cast the base of the hole in a quick-drying concrete, ensuring the base is level and that the foundation box when inserted into position, will be flush with the ground.

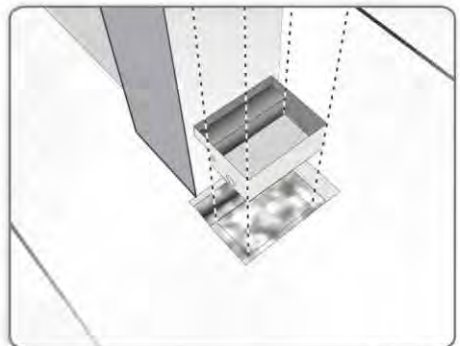

FIGURE 8

4. Fold the two anchor tabs at 45° away from the base of the foundation box just prior to inserting it into the hole.

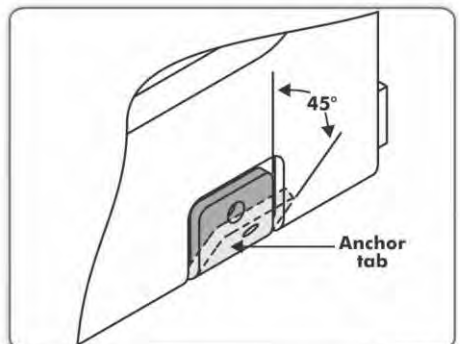

FIGURE 9

5. Cover the drainage holes on the inside with duct tape.

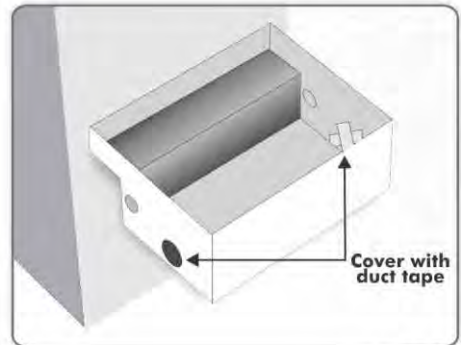

FIGURE 10

6. Insert the **foundation box** into the hole. Ensure the box is placed in a horizontal position, with the casing pivot at exactly 90° to the base, and perfectly aligned with the gate's hinge.
7. Lay a 30mm PVC conduit through the cable hole – the conduit must be routed back to the controller housing.

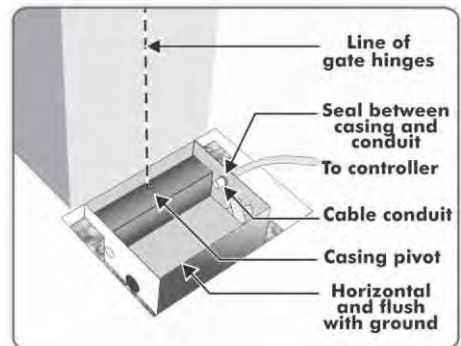

FIGURE 11

8. Complete casting the foundation box by filling in around the sides with concrete.

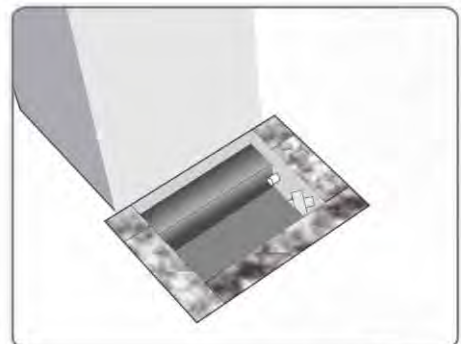

FIGURE 12

9. As soon as the previous step is completed, determine the position on either side of the foundation box to which the drainage holes will lead. Prepare drainage shafts as follows:

- Dig drainage shafts next to the concrete foundation adjacent to the drainage holes of the foundation box
- Shaft dimensions are approximately - 200mm diameter x 500mm deep

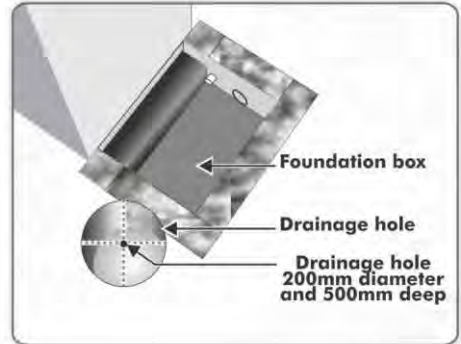

FIGURE 13

10. Before the concrete has completely set remove the duct tape from the drainage holes and carefully core through the side wall of the concrete foundation into the drainage shaft.
11. Ensure that there is a slope in the coring between the drainage hole and the shaft so that water will be able to drain away.
12. Fill the drainage shafts with crushed stone or pebbles.

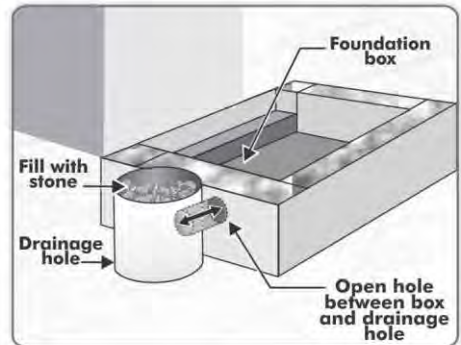

FIGURE 14

Motor and gate assembly

1. Remove the bottom hinge from the gate – only one hinge on each gate is required, with the drive unit itself serving the purpose of the bottom hinge.

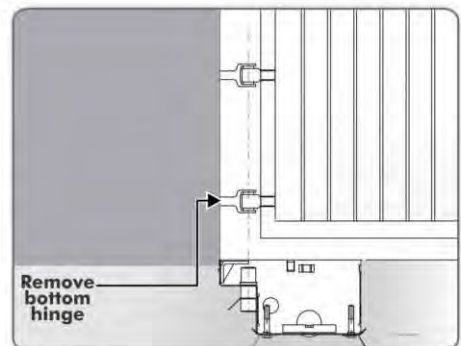

FIGURE 15

- Assemble the **drive arm** onto the **gearbox** just above the **limit switch cam disc**, firmly tightening the cap screw to a maximum torque of 45Nm.

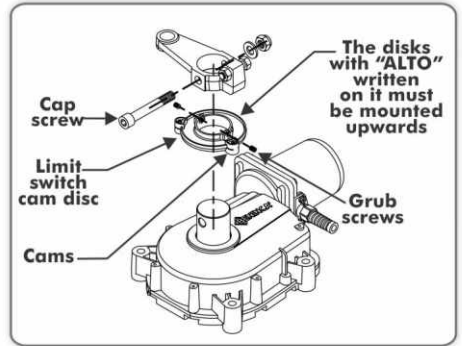

FIGURE 16

- Orientate the gearbox and motor assembly according to the mounting configuration (standard or inside). Lower the motor into the **foundation box** onto the mounting bolts in the base of the box and tighten in position using the M10 nylon nuts supplied.

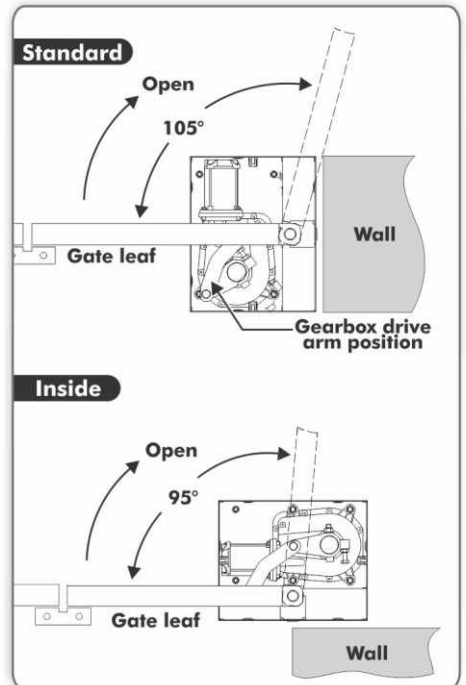

FIGURE 17

4. Join the **linkage arm** to the **drive arm**.

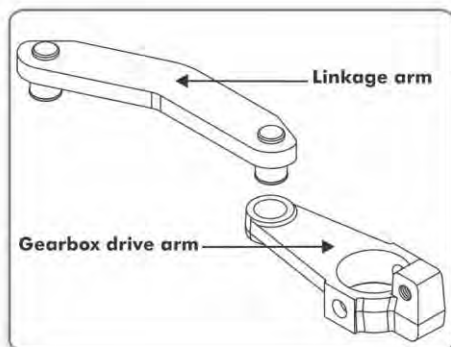

FIGURE 18

5. Pre-assemble the **drive assembly** consisting of the **operator output drive arm**, **drive shoe** and **manual release mechanism**.

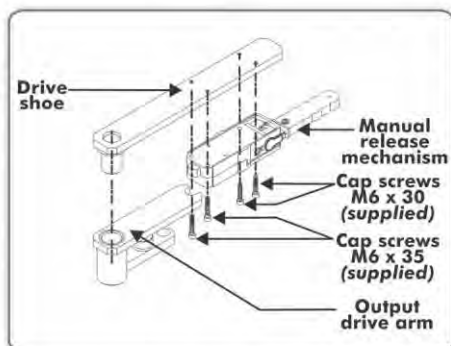

FIGURE 19

6. Weld this to the underside of the gate frame, ensuring that the pivot on this assembly is **perfectly aligned** with the top hinge of the gate.



Align the top hinge with the pivot.

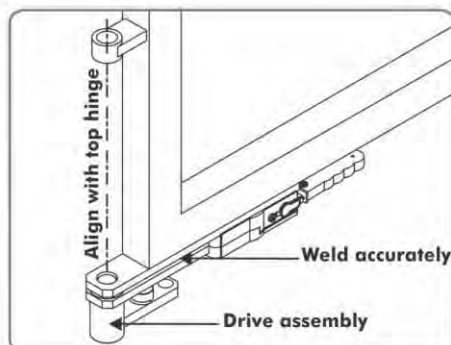

FIGURE 20

7. Re-install the gate ensuring that the **drive assembly ball bearing** is placed in the cup of the foundation box pivot before lowering the **drive assembly** onto the pivot.

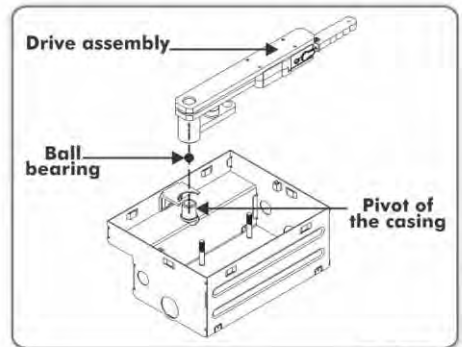

FIGURE 21

8. Join the **linkage arm** together with the **drive assembly**, as mentioned in point four on the previous page.

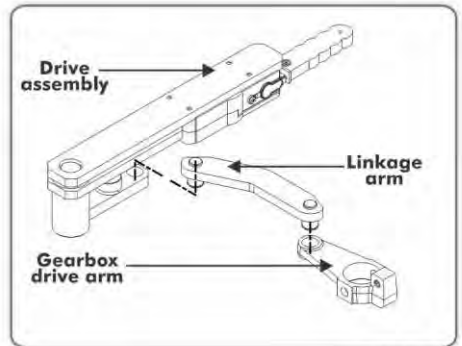

FIGURE 22

Limit switches and mechanical endstops

Closed endstop

1. It is necessary to mount a solid mechanical endstop into the ground. Ensure that the gate leaves stop firmly up against the stop and are perfectly aligned with each other in the closed position.

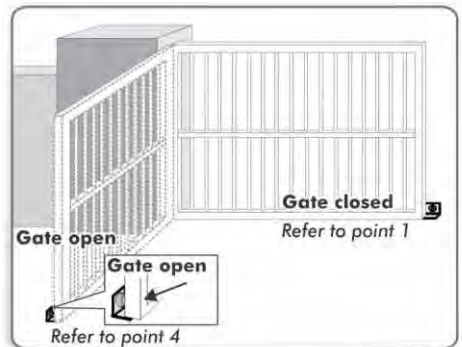

FIGURE 23

Gate lock

2. For greater security and if the gate leaf is wider than 2.5m, it is recommended that a gate lock is fitted together with the mechanical endstops to fully secure the gates in the closed position.

Open endstop

3. It is possible to use the internal limit switch to stop the gates in the open position.
4. Alternatively mechanical endstops can be used, mounted where each leaf swings to, in the open position.
5. The **limit switch disc** should already have been mounted onto the motor's output shaft at an earlier stage.
6. Assemble the microswitch group in either of the positions available, depending on the type of installation.
7. Only one of the two microswitches provided will be used.
8. Determine which microswitch will be activated when the gate opens.
9. Select the **common** and **normally-open** terminals of this microswitch to be connected to the controller:
 - **Black** – Common
 - **Blue** – Normally-open: use
 - **Red** – Normally-closed: ignore
10. Adjust the open limit switch by loosening the screw and then moving the disc until the open microswitch is triggered in the desired position.
11. Close the foundation box by adding the cover plate, and securing it to the box via the cover fixing brackets.

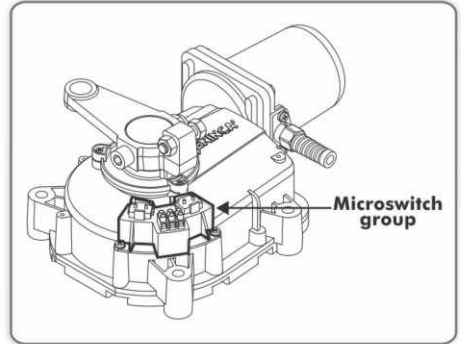

FIGURE 24

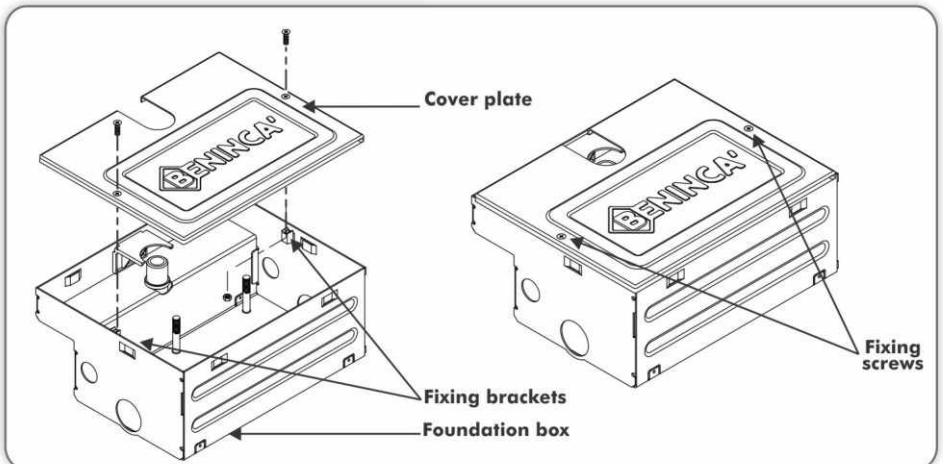

FIGURE 25

10. Electrical setup

1. Always check that the circuit breaker in the electrical panel is in the OFF position, and that all high voltage circuits (more than 42.4V) are completely isolated from the mains supply before doing any work.
2. Ensure that all low voltage systems (less than 42.4V) are suitably protected from damage, by disconnecting all sources of power such as chargers and batteries before doing any work.
3. All electrical work must be carried out according to the requirements of all applicable local electrical codes. (It is recommended that a licensed electrical contractor perform such work.)



Secure control box to wall

1. Secure control box to the wall using the most appropriate means.



Be sure to position the wall box so as not to cause any hazards during and after the installation.

Preferably mount the wall box:

- Out of direct sunlight
- At a comfortable working height
- Away from garden sprinklers etc.
- To allow easy access even when the gate is open

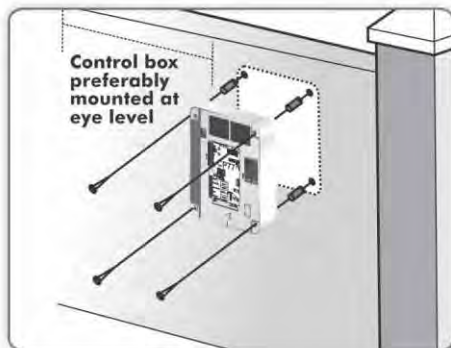

FIGURE 26

Connect all wiring

2. Connect all cables as required to the control card and battery charger, according to the wiring diagrams under Section 10, 11 and 12.

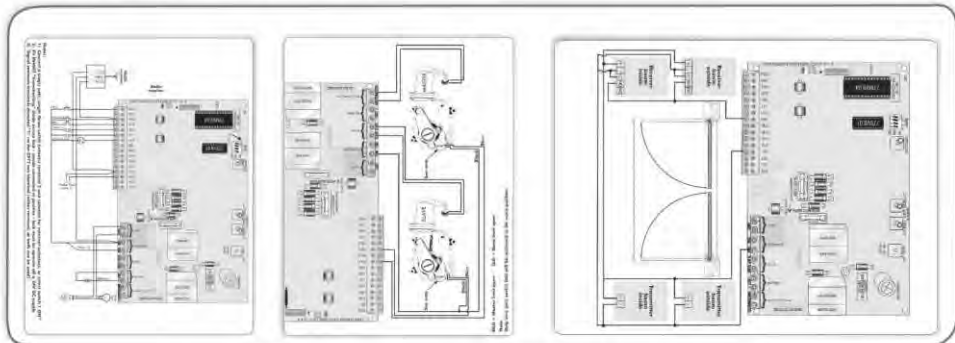

FIGURE 27

3. Ensure that both the controller and the charger are effectively earthed for improved lightning protection.

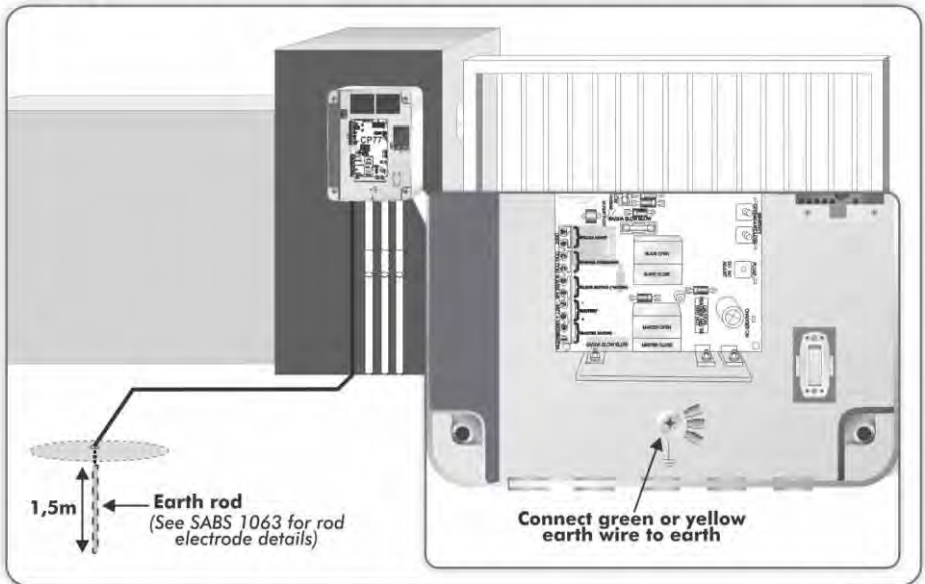

FIGURE 28



- Earth system at the gate using a copper earth spike.
- Ensure that the system is connected to ESCOM or main earth.

4. Check that the charger is connected to the controller.



Ignore the fact that the terminals 15 and 16 are marked 15V on the control card. The model CP77/24V is modified for a 30V AC supply.

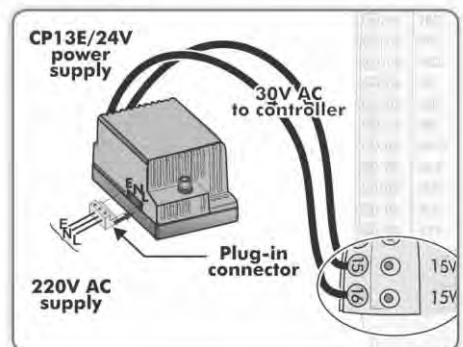

FIGURE 29

11. Wiring diagram for safety beams

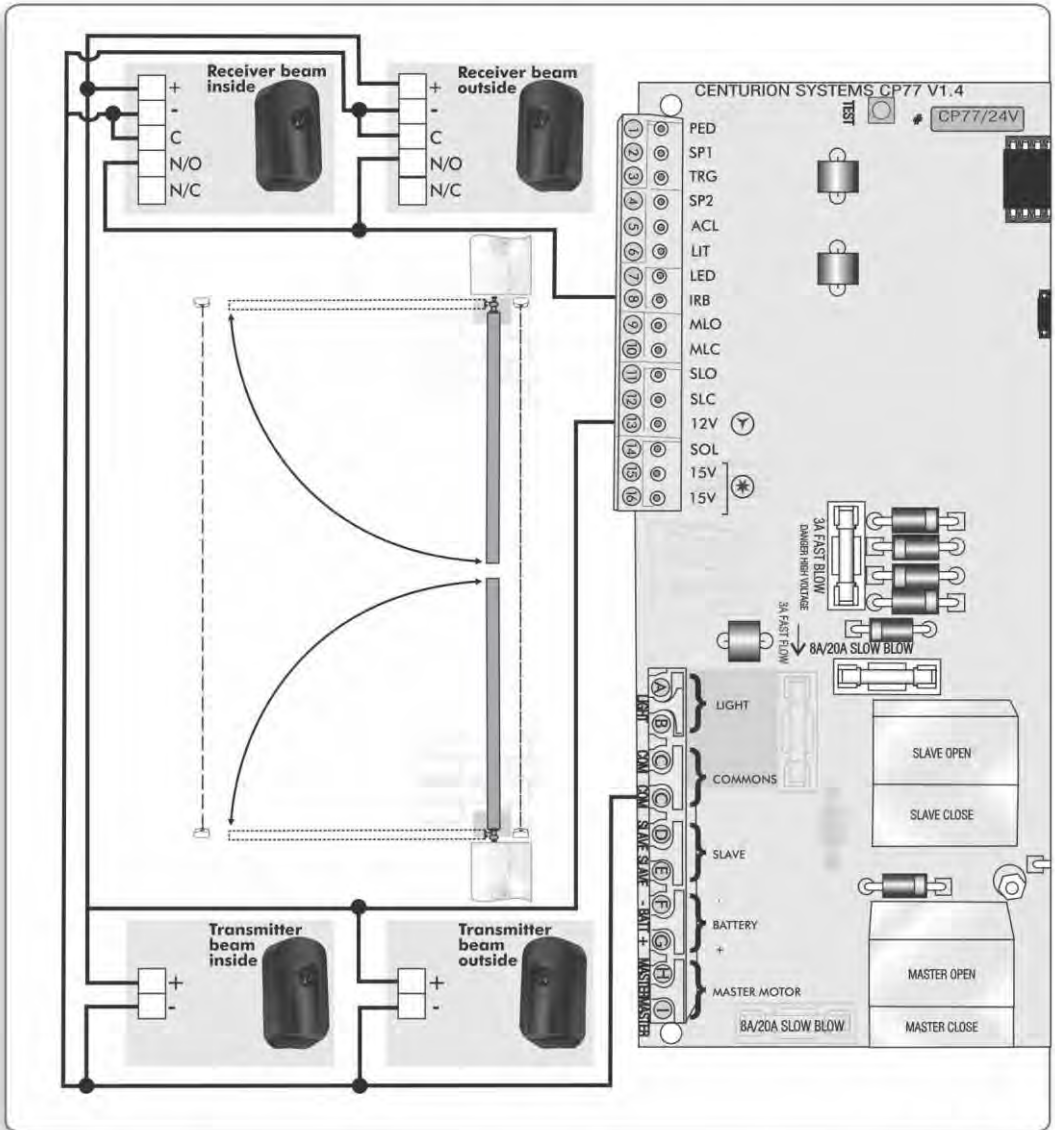

FIGURE 30



- Ⓜ Although this terminal is marked as 12V the controller is modified to supply 24V DC
- Ⓢ Although these terminals are marked as 15V the controller is modified to be supplied by 30V AC

12. Wiring diagram for other accessories

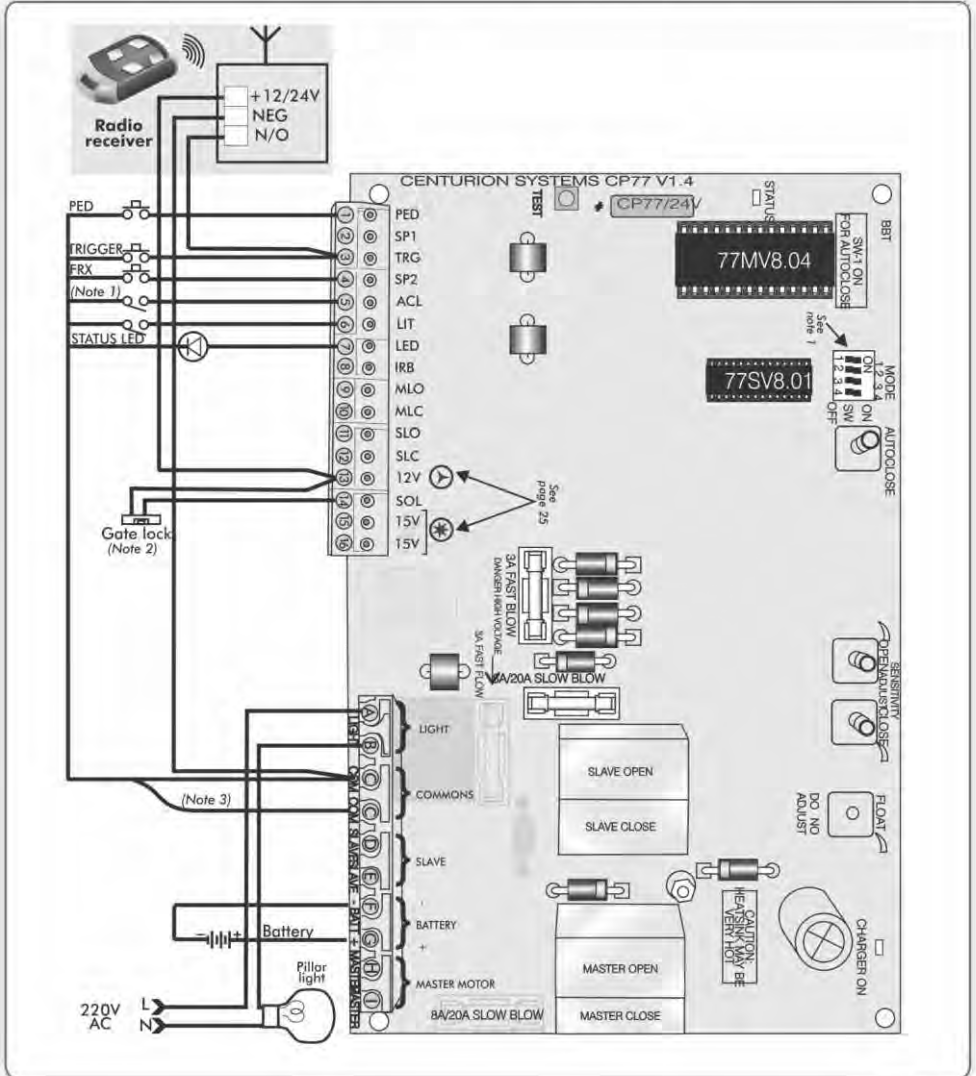

FIGURE 31

1. Connect a single pole, single throw switch between terminal 5 and common for external autoclose, or select switch 1 "ON"
2. Fit IN4007 "freewheeling" diode across lock - anode connected to positive - lock must operate off a 24V DC supply
3. Signal common terminals denoted "C" on the CP77 are identical (either terminal, or both can be used)



13. Wiring diagram for motors and open limits

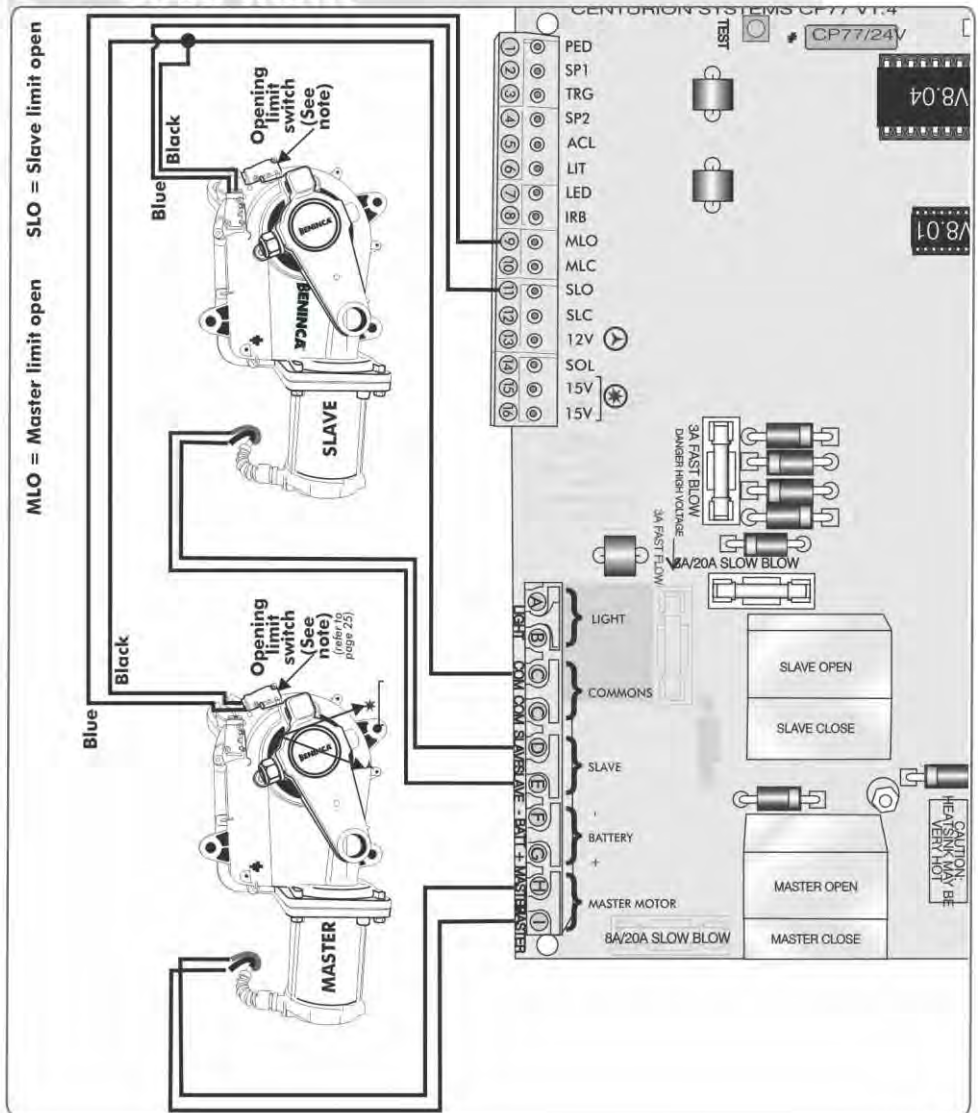

FIGURE 32

- Ⓜ Although this terminal is marked as 12V the controller is modified to supply 24V DC
- Ⓢ Although these terminals are marked as 15V the controller is modified to be supplied by 30V AC



• Only connect the limit switch that will be activated in the open position

5. Check that the 24V battery supply is connected to the controller.



Ensure that the battery polarity is correct.

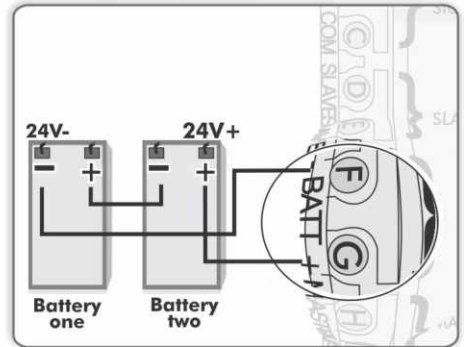

FIGURE 33

6. Switch on the mains supply (via isolator).
7. Check that the **green** charger LED on the controller lights up.

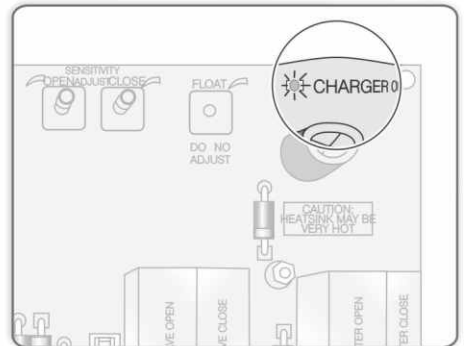

FIGURE 34

Control card setup

8. Select dipswitch settings to give required Mode of Operation.

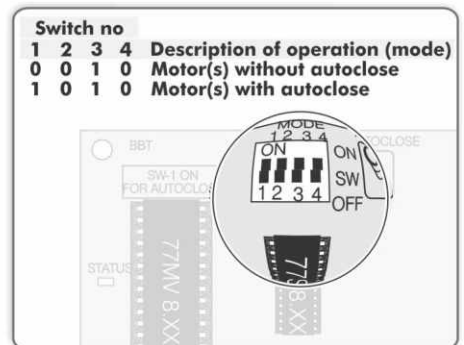

FIGURE 35

9. If Autoclose has been selected, set Autoclose timer potentiometer to suit. Clockwise increases time (range 5-30 seconds).



It is always recommended to have infrared safety beams fitted when using the Autoclose feature.

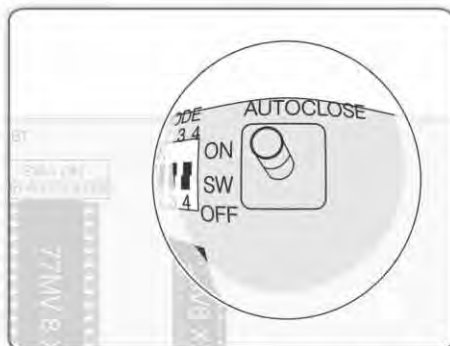

FIGURE 36

Set motor polarity

10. Identify status LED, which will give information on gate status, whether gate is open, closed, etc.

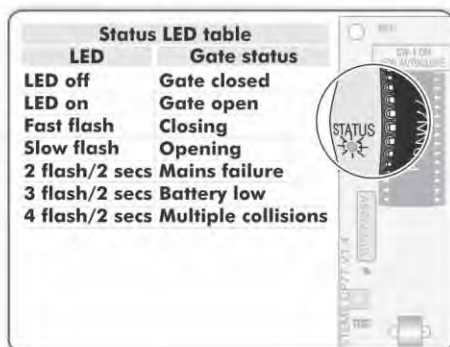

FIGURE 37

11. Set the polarity of each motor by triggering the control card, making sure that the gate direction for each leaf corresponds with the status LED.
12. Swap motor wires on the control card to give correct motor rotation.

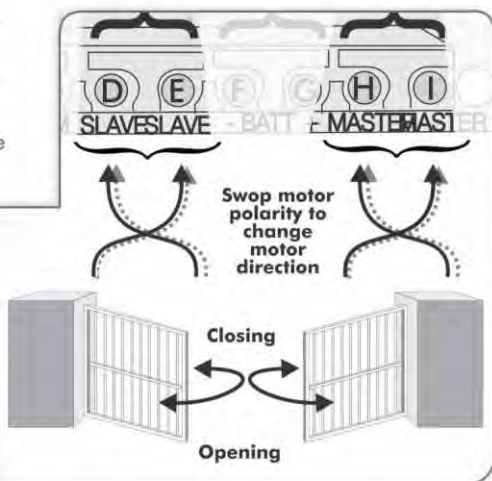
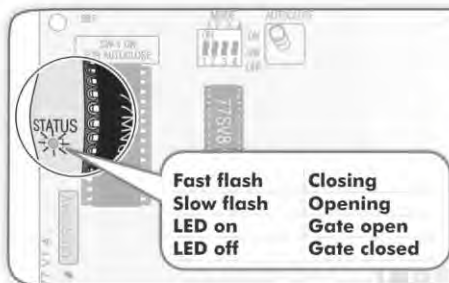

FIGURE 38

Collision sensitivity adjustment

13. Adjust the sensitivity on the controller such that the gate(s) will open and close reliably, but not cause damage to persons or objects in the path of the gate(s).
14. The motor will just stop when the gate(s) hits an obstruction while opening or closing.

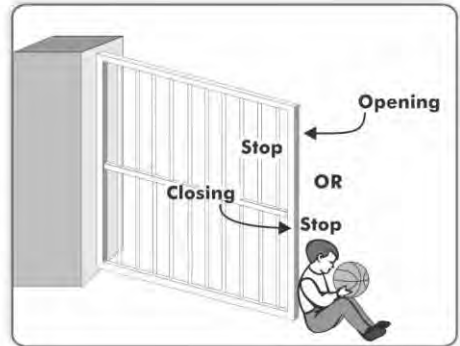

FIGURE 39

15. There are two sensitivity potentiometers on the CP77/24V controller. The left-hand potentiometer is used to set the sensitivity of both the master and slave gate(s) when opening. The right-hand potentiometer is used when the gate(s) are closing.

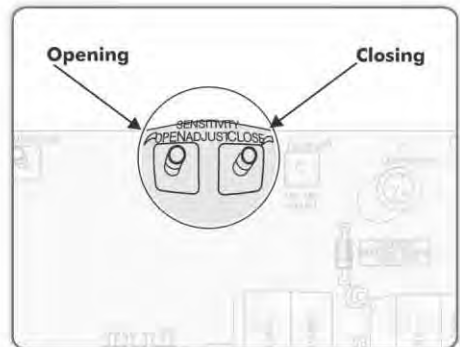

FIGURE 40

16. Start with the potentiometers set to a midway position.

17. Trigger the gate(s) and when the gate(s) have traveled approximately halfway through the opening or closing movement, obstruct the gate(s) noting the effort required to stop them.

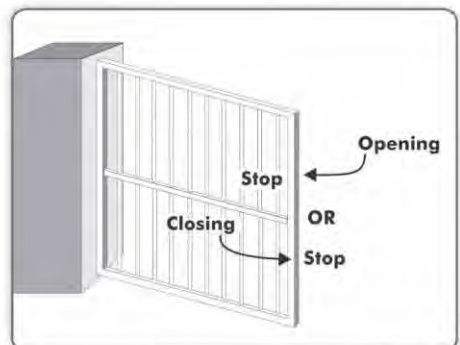

FIGURE 41

18. Adjust the respective potentiometer depending on whether the gate was opening or closing, clockwise if the gate stopped too easily or anti-clockwise if the gate was hard to stop.

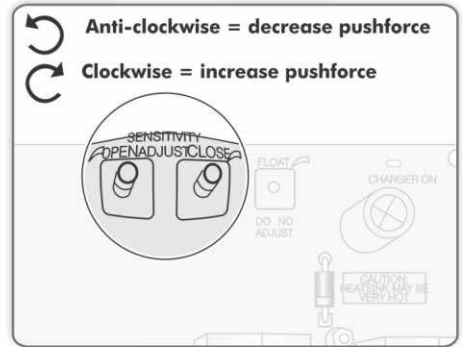

FIGURE 42

14. Controller features

Inherent safety features

Safety (Collision sensitivity)

If the gate is obstructed, the internal collision circuitry will activate the gate whether opening or closing to just stop.

The response of the system to a collision will vary according to the sensitivity level that has been set. There are two potentiometers, one for setting the gates while opening and the second while closing.

Clockwise adjustment reduces the sensitivity and increases the push force.

- **Collision count**

A counter monitors the number of collisions that the gate experiences before the gate reaches the fully closed position. If the value exceeds a preset value of four, the controller shuts down for a period of two minutes. A valid trigger received after this shut-down period will reset the system.

As an indication, the status LED will flash four times every two seconds. The multiple collision fault indication will continue to flash indefinitely or until a valid trigger has been received.

Selectable features

Autoclose

- **Autoclose status**

The Autoclose feature when turned on, has the function of automatically closing the gate after an adjustable autoclose time.

- **Autoclose time**

A potentiometer is provided on the controller to adjust the Autoclose time between five and thirty seconds.

- **Autoclose override**

It is possible for the user to temporarily turn off Autoclose. To activate Autoclose override, **press and hold** the button of the remote or the gate intercom (any device connected to the TRG input) for at least three seconds. Release the button. The gate will open fully and stay open.

The gate response will be to start opening on the first TRG trigger, and then to stop as soon as the Autoclose override feature is activated. On clearing of the TRG input, the gate will continue opening until fully open. The Autoclose feature is now off and the gate will remain open indefinitely.

The next signal received on TRG will clear the Autoclose override feature, close the gate, and set the Autoclose feature back to normal.

Input features

Gate trigger - Modes of Operation (TRG)

- The CP77 supports three Modes of Operation: **Standard**, **Condominium** and **PIRAC**. However, the gate motors rely on a mechanical endstop to stop the gate in the closed position and the controller must be set so that they shut off when the gates reach these limits. This limits the system to STANDARD Mode of Operation.

- Standard Mode via gate trigger**

When stationary, a trigger impulse on TRG will cause the gate to either open or close. While the gate is moving, a trigger impulse on TRG will stop the gate. A third impulse on TRG will cause the gate to reverse its direction of travel, i.e. the action is **start - stop - reverse**.
- Pedestrian Opening (PED)**

This feature is associated with the PED input on the controller. When activating this input, the system will open the master gate only to the pedestrian open position (fixed width opening of approximately one metre) and then automatically close after a preset pedestrian Autoclose time of five seconds. If activation of the PED input is maintained, the gate will remain open, and when de-activated the gate will close after the pedestrian Autoclose time.
- Free-exit input (SP2)**

The Free-exit facility is activated by using the dedicated input to the control card marked SP2.

The Free-exit facility allows for easy exit of vehicles from a townhouse or parking lot. When driving through the free-exit beam or over an inductive loop the controller will automatically open the gate. The free-exit beam facility will only open the gate and therefore the Autoclose facility, described earlier, must be enabled to close the gate.
- Holiday Lockout (SP1)**

When this feature is enabled using typically a latching device connected between this input and COM, all inputs that can operate the gate are inhibited. The feature is designed so that even if it is enabled while the gate is moving or in the open position, it will only activate when the gate is back in the closed position.

For instance this ensures that while the property is left unattended for extended periods of time, a would-be intruder cannot try and tamper with any of the inputs such as the intercom gate release button, pedestrian keyswitches / keypads to operate the gate. It also automatically disables any free-exit devices such as underground loops, etc.
- Infrared safety beams (IRB)**

External safety/detection devices are necessary to sense the presence of a person or vehicle moving through the entrance and ensure that the gate cannot be closed onto the obstruction. By comparison, the inherent safety mechanism described earlier, relies on the gate hitting the obstruction before reacting.

An infrared safety beam is ideal in domestic installations and will accommodate a multitude of potential obstructions such as people, vehicles and pets. However, in industrial applications with mainly vehicles, large and small, moving through the entrance, an underground loop can be a more reliable detection device.

With the gate in the open position and the detection device activated, the gate cannot be closed. If the gate is already closing when the detection device is activated, the gate will immediately stop and re-open. If the gate is closed or opening and the detection device is activated, the signal from the device will be ignored.

Similarly, if the Autoclose feature is selected, the gate will remain open while the detection device is activated. The moment the detection device is cleared the gate will only close after the preset autoclose time has expired.

Outputs with associated features

• Gate status LED (LED)

External gate status indicator. This output provides a low current drive to light up a LED which can be used to indicate the gate status remotely.

For instance if the gate is not visible from the intercom handset inside the house, which is used to communicate with a visitor at the gate and operate the gate, an LED fitted to the intercom, wired to the LED output on the gate controller, will give the necessary feedback about the status of the gate.

• Courtesy (Pillar) light (LIGHT/LIGHT)

This feature is associated with the LIGHT connections on the controller.

The pillar light circuit has multiple functions:

- It operates as a courtesy light and switches on for a preset timed period of two minutes every time the gate is activated
- Pillar Light Control (LIT): It can be turned on permanently by making a contact via a single pole, single throw switch connected between LIT and COM

• Auxiliary wallbox card

- An LED interface, which provides three inputs for switching LEDs, is included with the kit
- A typical use would be to connect the controller's status LED to the interface, and in so doing ensuring that you are always aware of your gate's movements. It is also a handy notification system for power failures, multiple collisions, etc.
- In addition, there is an optional anti-tamper switch which can be connected to a third party alarm. Should the cover be lifted without first deactivating the alarm, the buzzer will sound warning residents that the device is being tampered with
- If a 12 V DC buzzer is used, it can be powered directly from the controller's 12V output, eliminating the need for an additional power supply
- The external indicator is connected between LIT and COM

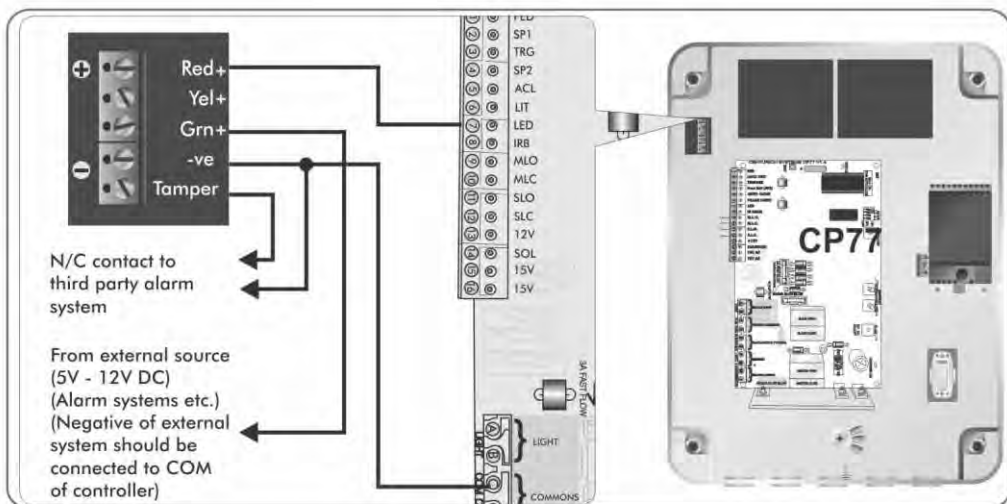

15. Description of terminal functions

PED

Pedestrian Opening input. (A normally-open potential-free input). Momentarily connecting this input to COM will cause the master gate to open to the pedestrian open position. For more information refer to the pedestrian feature under Section 13.

SP1

Holiday Lockout. (This is a potential-free, latching input). For as long as a connection between this input and COM is maintained the controller will behave normally. But, when this connection to COM is broken all inputs are inhibited. For more information refer to the Holiday Lockout feature under Section 14.

TRG

Trigger input. (A normally-open potential-free input). Momentarily connecting this input to COM will cause the gate to open or close depending on the operating mode selected. For more information refer to the gate trigger feature under Section 14.

SP2

Free-exit input. (A normally-open potential-free input). Momentarily connecting this input to COM will cause a gate which is closed, or closing, to open or re-open. If the gate is open, or opening, the signal has no effect other than to reset the Autoclose timer (if selected). Free-exit (FRX) never initiates a closing cycle. The only way to close a gate, if only the FRX input is used, is to activate the Autoclose feature on the controller.

ACL

Allow external activation of the Autoclose facility. (This is a potential-free, latching input). Using the switch to make a contact between this input and COM, will cause the Autoclose feature to be switched on. Breaking the contact will disable the feature.



The dipswitch on the controller, which can also be used for enabling the Autoclose feature, must remain switched off in order for the external switch to operate.

LIT

Activates the **Pillar Light output.** (This is a potential-free, latching input). Using the switch to make a contact between this input and COM, will cause the **light** relay to energize. Breaking the contact will de-energise the relay.

LED

External gate status indicator. (A low current output signal.) An output terminal which provides a low current drive (approx. 4,5V DC, 20mA) to a LED which can be used to indicate the gate status remotely. If more than three LEDs are required it is necessary to fit the CP78 Multi-LED driver card. For more details on the feedback about the status of the gate provided by the status LED refer to Section 16.

IRB

Closing edge safety input. (A normally-open potential-free input). When this connection is made it will prevent the gate from closing if it is stationary, and will stop and reverse the gate if it is closing. This input has no effect if the gate is opening.

MLO

Open limit contact for master motor. The contact must be normally-open. The contact is wired between this point and common.

MLC

Closed limit contact for master motor. The contact must be normally-open. The contact is wired between this point and common. Not used if a closed mechanical endstop is used to stop the gate.

SLO **Open limit contact for slave motor.** The contact must be normally-open. The contact is wired between this point and common.

SLC **Closed limit contact for slave motor.** The contact must be normally-open. The contact is wired between this point and common. Not used if a closed mechanical endstop is used to stop the gate.

12V Auxiliary supply for external accessories such as radio receivers, safety beams, etc. This is a 24V DC supply, maximum current 1.5A.



Ignore the fact that the control card is marked 12V. The model CP77/24V is modified for a 24V output.

SOL **Solenoid strike.** A solenoid strike lock can be connected between 24V and SOL. Note that the maximum current draw allowed for the lock is 2A. Should the solenoid lock exceed this current rating it is necessary to use an interposing relay. If fitting a magnetic lock an interposing relay must be fitted to facilitate a normally-closed contact to drive the lock.

15V/15V Input from charger transformer for battery charger circuit. 28-32V AC mains, approximately 30V AC.



Ignore the fact that the control card is marked 15V. The model CP77/24V is modified for a 30V AC input.

LIGHT **Pillar light connection.** These two terminals provide a normally-open potential-free contact, which is generally used to switch on a Pillar Light (Courtesy Light). This contact is fuse-protected – 5A. The contact is activated for a period of two minutes each time the gate is operated. Using the LIT input referred to above, the **light** contacts can be energized independently of the operation of the gate.

COM/COM The **common** termination point. All trigger signals, etc. have their return path to one of the COM terminals.

SLAVE/SLAVE Motor output – connects to the **blue** and **brown** slave motor wires.

BATTERY+ Negative 24V battery connection.(Battery terminal normally indicated as - or **black**)



Two 12V batteries, wired in series, must be used in this circuit.

BATTERY- Positive 24V battery connection.(Battery terminal normally indicated as + or **red**).

MASTER/MASTER Motor output – connects to the **blue** and **brown** master motor wires.

16. Diagnostics

Diagnostic LEDs

The CP77 controller has a series of diagnostic LEDs which indicate the state of the inputs.

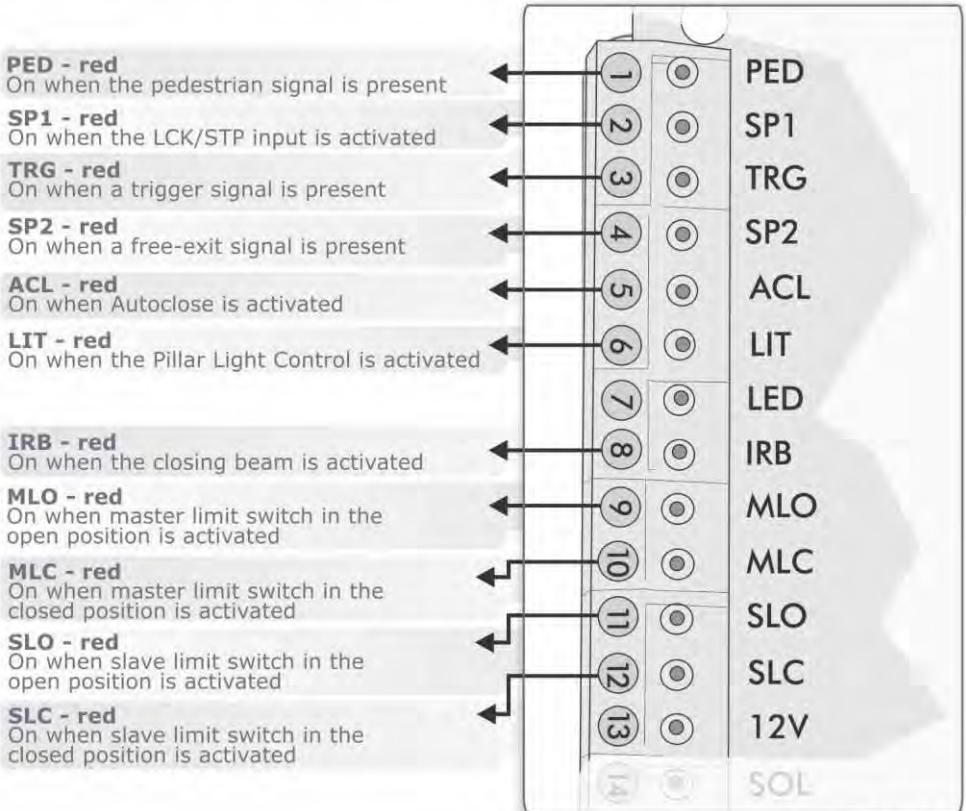

FIGURE 43

Gate status LED

Status - red

This LED indicates the state of the gate as per table below

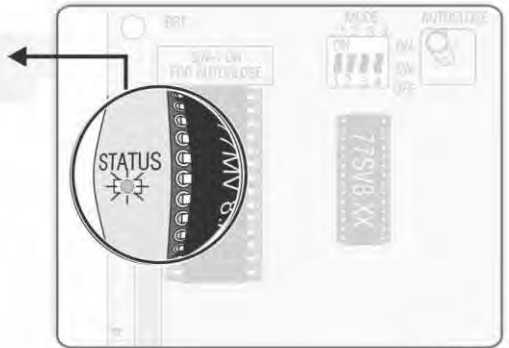

FIGURE 44

Off	Gate is closed
On	Gate is partially or fully open
Continuous slow flash	Gate is opening
Continuous fast flash	Gate is closing
One flash every two seconds	Pillar light override is activated
Two flashes every two seconds	No mains present
Three flashes every two seconds	Battery voltage is low
Four flashes every two seconds	Multiple collisions have occurred

17. Manual release operation

1. Hinge open the dust flap, insert key into lock and give 1/8 turn clockwise.

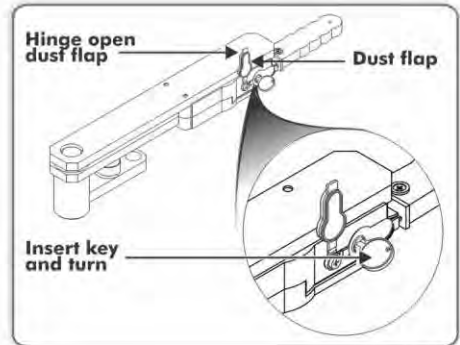

FIGURE 45

2. Pull manual release sideways to disengage gate leaf from operator.



If an external lock is fitted this must also be released.

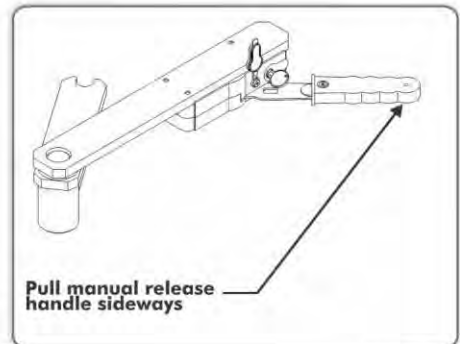

FIGURE 46

3. To re-engage gate leaf, swing handle back to centre position, re-engage lock and remove key. Swing leaf and re-engage with drive arm assembly.



Remember to refit dust cap over lock.

18. Installation handover

Once the installation has been successfully completed and tested, it is important for the installer to explain the operation and safety requirements of the system.

NEVER ASSUME THE USER KNOWS HOW TO SAFELY OPERATE AN AUTOMATED GATE! Even if the user has used one before, it does not mean he knows how to SAFELY operate it. Make sure that the user fully understands the following safety requirements before finally handing over the site.

The following needs to be understood by the user:

- How to operate the manual release mechanism (Show them how by demonstration)
- How the obstruction detection and all other safety features work (Show them how by demonstration)
- **All the safety considerations associated with operating an automated gate. The user must also understand that he/she is responsible for explaining these safety instructions to all other users of the automated system**



- **Do not activate the gate operator unless you can see it and can determine that its area of travel is clear of people, pets, or other obstructions**
- **NO ONE MAY CROSS THE PATH OF A MOVING GATE. Always keep people and objects away from the gate and its area of travel!**
- **NEVER LET CHILDREN OPERATE OR PLAY WITH THE GATE CONTROLS, and do not allow children or pets near the gate area**
- **Be careful with moving parts and avoid close proximity to areas where fingers or hands could be pinched**
- **Secure all easily accessed gate operator controls in order to prevent unauthorized use of the gate**
- **Keep the automated gate system properly maintained, and ensure that all working areas are free of debris and other objects that could affect the gate operation and safety**
- **On a monthly basis, check the obstruction detection system and safety devices for correct operation**
- **All repair and service work to this product must be done by a suitably qualified person**

This product was designed and built strictly for the use indicated in this documentation. Any other use, not expressly indicated here, could compromise the good condition/operation of the product and/or be a source of danger!



Centurion Systems (Pty) Ltd. does not accept any liability caused by improper use, of the product, or for use other than that for which the automated system was designed.

Notes

Lined area for writing notes.



Notes



Notes





Sharecall 0860-CENTURION (0860 236 887)
Head Office: +27 11 699 2400

Sharecall Technical Support 0861 003 123 or
+27 11 699 2481
from 07h00 to 18h00 (GMT+2)

(Sharecall numbers applicable when dialed from within South Africa only)



0.07.A.0064_22072013

www.centsys.com