

R3R5 quick setup guide

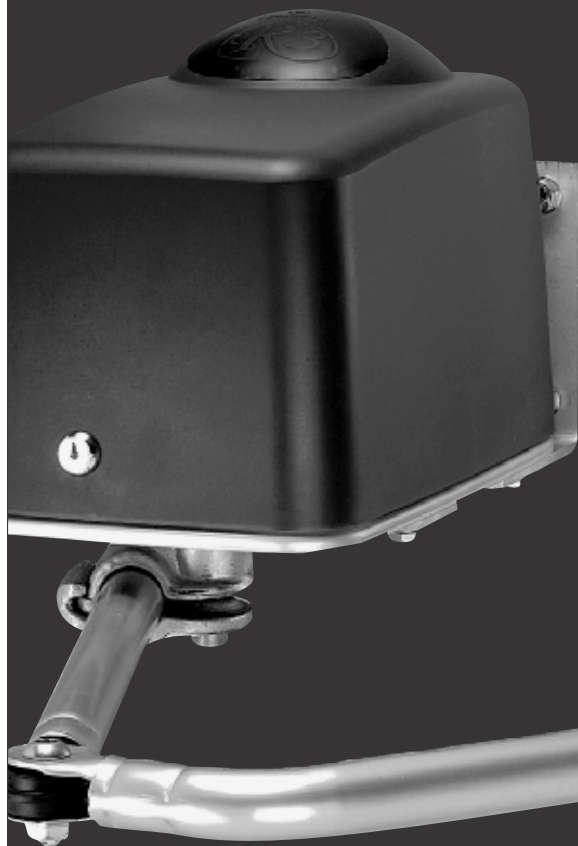

CENTURION



**ROTARY
SWING GATE
OPERATOR**

1 REQUIRED TOOLS & EQUIPMENT

Check that you have all the tools required. (IM page 12)

2 SITE CONSIDERATIONS

Check for the safety and suitability of the site by looking at: (IM page 13)

- All safety and local authority requirements.
- That the gate is within the operator specifications.
- Check that there is enough ground clearance to enable assembly of the drivearm clamps. (See Figure 4)

3 CABLING REQUIREMENTS

Consider all cabling requirements and routing as in Figure 9. (IM page 14)

4 OPERATOR INSTALLATION

- Estimate the gate swing angle with figure 1.
- Then mark the operator's position according to figure 2 or 3. (IM page 15)

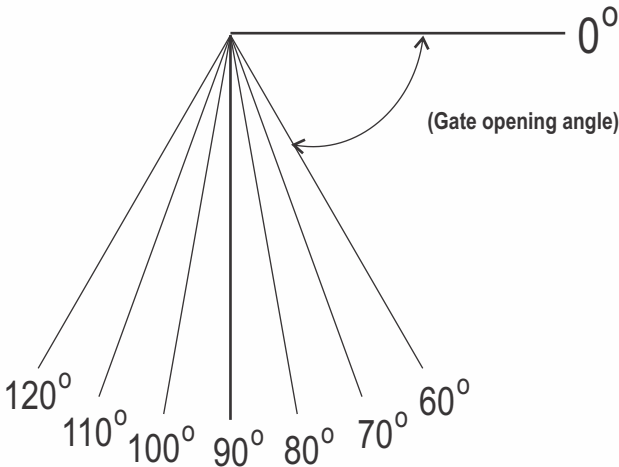
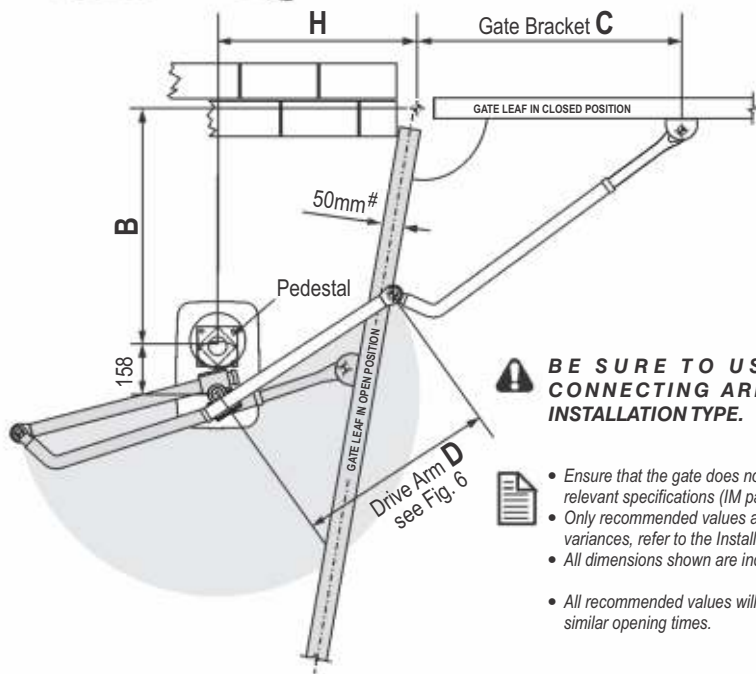

Figure 1 Gate Opening Angle Diagram

STANDARD PEDESTAL MOUNT



Pedestal Mount Installation



BE SURE TO USE A LONG CONNECTING ARM FOR THIS INSTALLATION TYPE.

- Ensure that the gate does not exceed the relevant specifications (IM page 9)
- Only recommended values are provided. For variances, refer to the Installation Manual.
- All dimensions shown are indicated in millimetres.
- All recommended values will result in gates with similar opening times.

Gate Opening Angle (Degrees)	H	B	C Gate Bracket
60	0	750	700
70	90	750	700
80	130	750	700
90	220	700	700
100	355	700	650
110	570	600	610
120	605	450	570

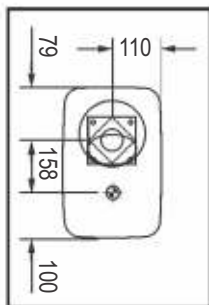
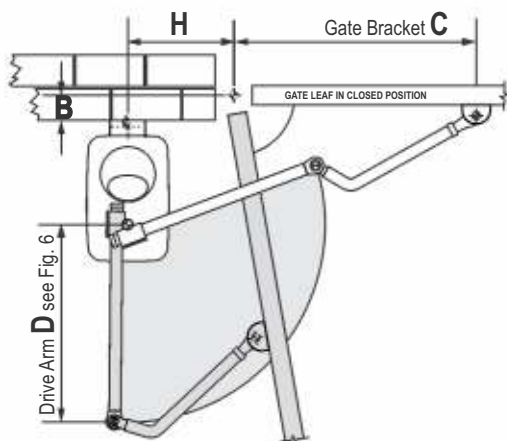

Figure 2 Standard Pedestal Mount Installation

PERPENDICULAR WALL MOUNT



Wall Mount
Installation



BE SURE TO USE A SHORT CONNECTING ARM FOR THIS INSTALLATION TYPE.



- Ensure that the gate does not exceed the relevant specifications (IM page 9)
- Only recommended values are provided. For variances, refer to the Installation Manual.
- All dimensions shown are indicated in millimetres.
- All recommended values will result in gates with similar opening times.

Gate Opening Angle (Degrees)	H	B	C Gate Bracket
60	140	180	700
70	180	180	700
80	180	140	700
90	210	140	700
100	305	180	700
110	380	80	700
120	485	80	610

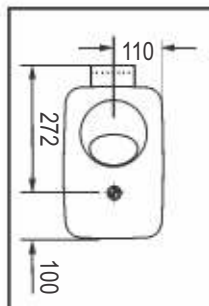

Figure 3 Standard Wall Mount Installation

5

MOUNT THE GATE BRACKET AND DETERMINE PEDESTAL HEIGHT

- Locate a suitable place for mounting the gate bracket according to dimension "C" in the tables of Figures 2 or 3.
- Determine pedestal or wall mount bracket height relative to gate bracket as in figure 4 and 5. (IM page 21)
- Mount the gate bracket.

PEDESTAL MOUNT INSTALLATION

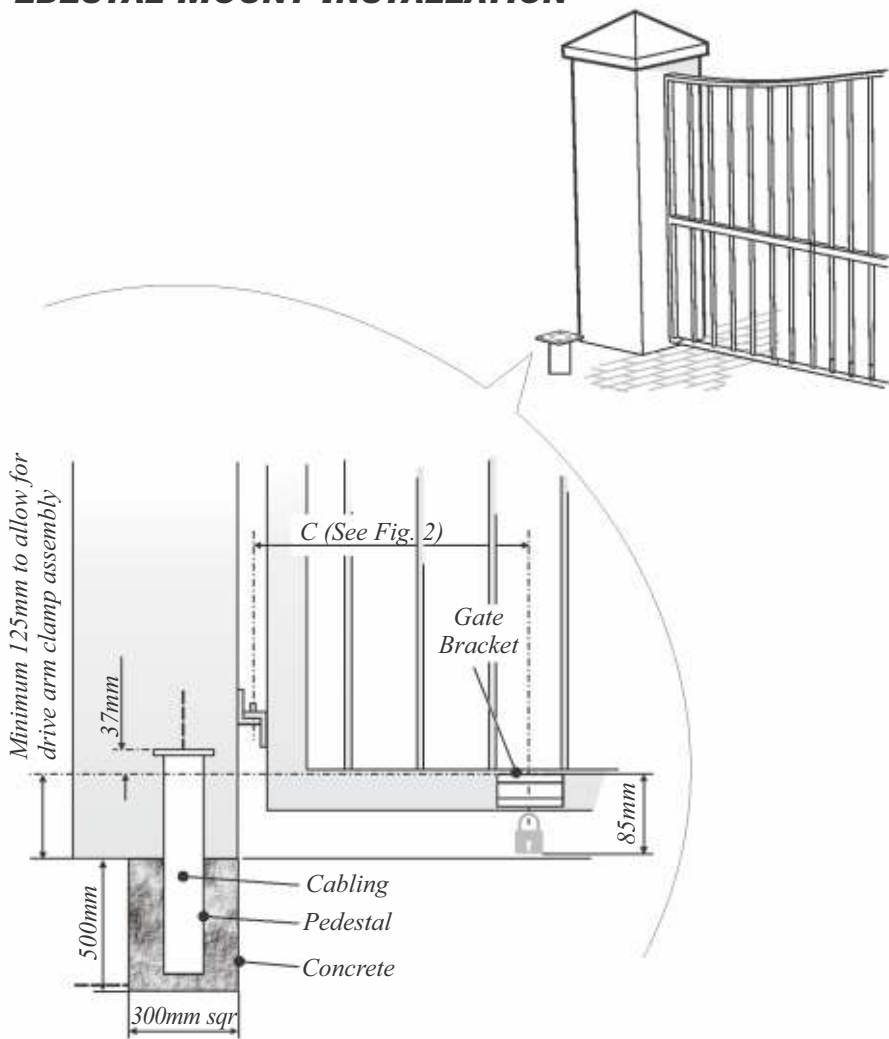

Figure 4 Pedestal/Gate Bracket vertical position

WALL MOUNT INSTALLATION

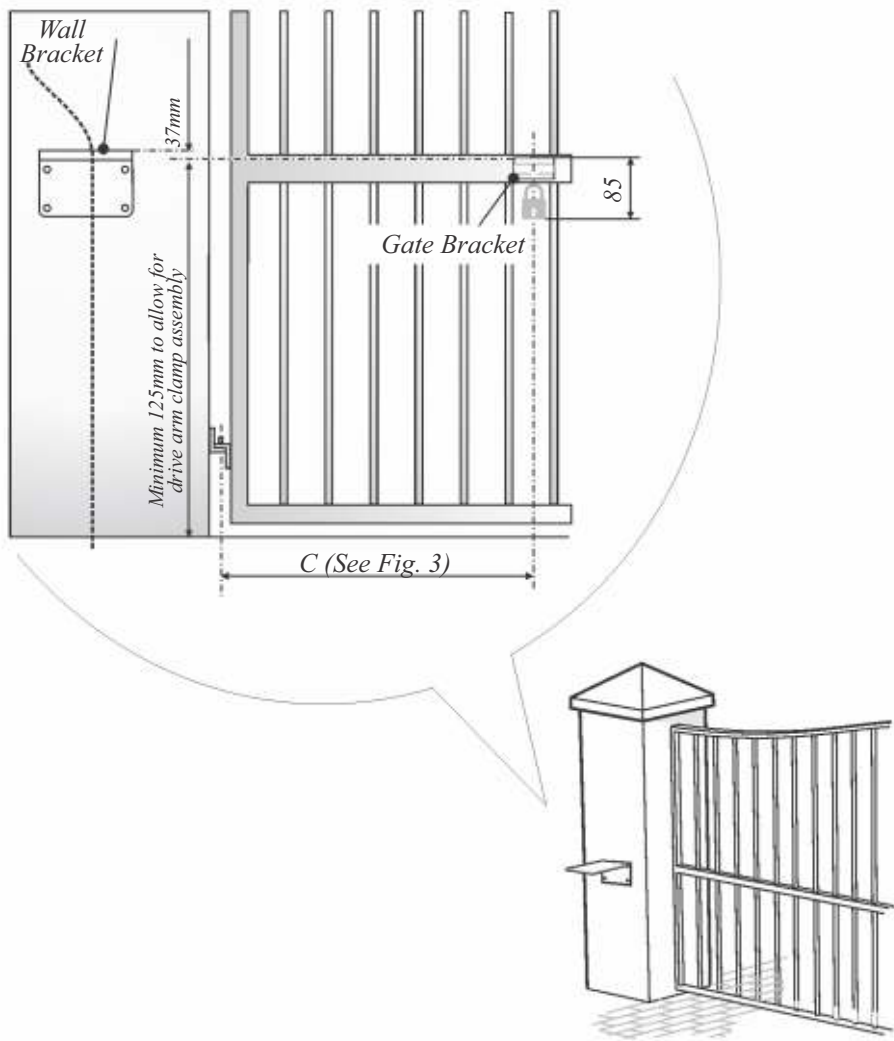

Figure 5 Wall/Gate Position

6 ROUTE CABLES & SECURE MOTOR

- Route cables as determined in the cabling plan in Figure 9.
- Make sure at least 400mm of cable protrudes above the pedestal or wall mount bracket. (IM page 22)

7 FASTEN GEARBOX IN POSITION

- Fasten the motor onto the pedestal adaptor plate or the wall bracket using the M8 bolts and washers supplied. (IM page 23)

8 CUT DRIVE ARM TO LENGTH

- Using the relevant tables below, read off the required drive arm length.
- Then cut the drivearm 50mm longer than D, as shown in Figure 6.

CUT DRIVEARM TO LENGTH

Gate Opening Angle (Degrees)	Standard Pedestal Mount Drivearm	Perpendicular Wall Mount Drivearm
	D	D
60	325	250
70	370	300
80	430	350
90	470	420
100	490	480
110	480	500
120	470	500

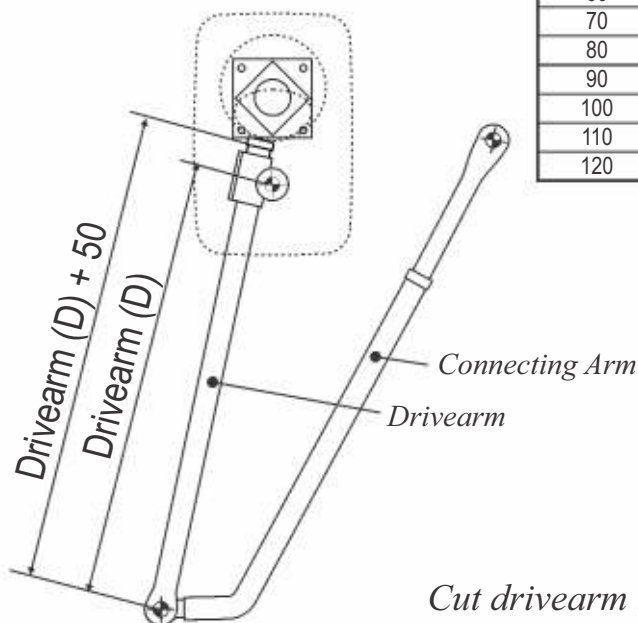

Cut drivearm length = D + 50mm

Figure 6 Cut Drive Arm Length

9

FIT THE DRIVE ARM

- Put the gearbox into manual mode. (*IM* page 24).
- Fit the drive arm to the operator as shown.

ASSEMBLE CLAMP TO DRIVE ARM

R3

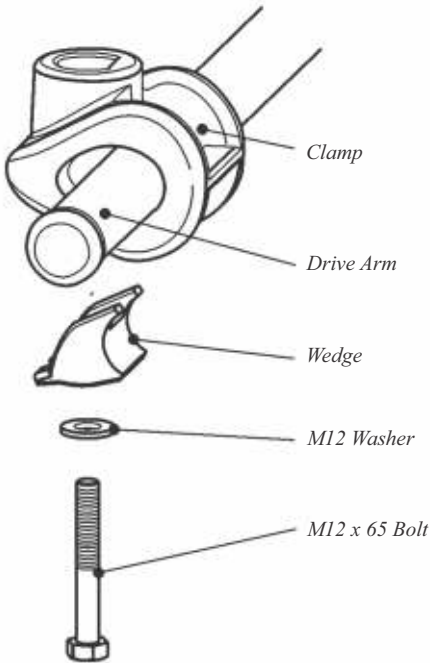

R5

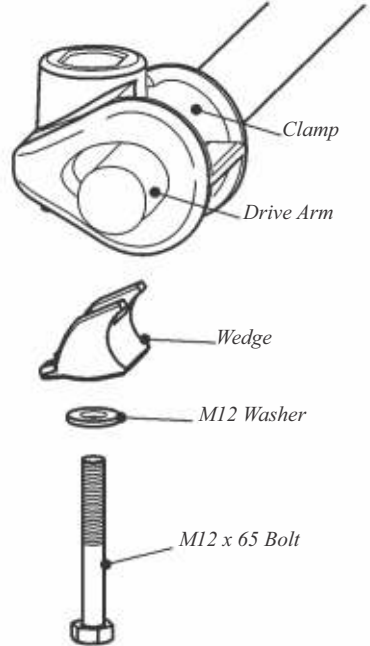

To mount: push clamp onto drive shaft, tap into place, slide drive arm into clamp, slip wedge in and fasten with bolt and washer.

Figure 7 Assemble Clamp to Drive Arm

10 SET THE CONNECTING ARM LENGTH

- Loosen the connecting arm slightly and move it to its fully retracted position.
- Open the gate $\frac{1}{2}$ way.
- Assemble the connecting arm to the gate bracket.
- Now slowly push the gate to its closed position. (The drive arm will turn, and the connecting arm will extend while doing so)
- Check that the hinge points of the gate bracket, connecting arm and motor output shaft are in a straight line as shown in Figure 8.
- Carefully unhook the connecting arm from the gate bracket and tighten lightly.
- Check the gate opens and closes sufficiently by manually operating the gate.

IF THE GATE OPENS TOO LITTLE

Lengthen the drivearm by 10 mm and **readjust the connecting arm.**

IF THE GATE OPENS TOO MUCH

Shorten the drivearm by 10 mm and **readjust the connecting arm.**

- Fully tighten connecting arm.
- Apply the warning decals supplied to either side of the gate frame.

ALIGNMENT OF HINGE POINTS

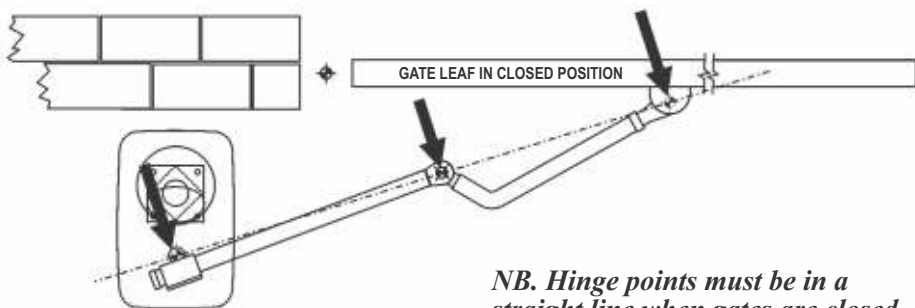

NB. Hinge points must be in a straight line when gates are closed

Figure 8 Align Gates

ELECTRICAL SET-UP

WARNING

1. Always check that the circuit breaker in the electrical panel is in the OFF position, and that all high voltage circuits (more than 42.4V) are completely isolated from the mains supply before doing any work.
2. Ensure that all low voltage systems (Less than 42.4V) are suitably protected from damage, by disconnecting all sources of power such as chargers and batteries before doing any work.
3. All electrical work must be carried out according to the requirements of all applicable local electrical codes. (It is recommended that a licensed electrical contractor perform such work.)

1 CONNECT ALL WIRING

- Connect all cables as required to the control card and battery charger (See Figure 11 & 12). (*IM* page 48 & 49)
- Check that the power source jumper is in the correct position. (PSU or STD refer to *IM* page 27, Fig. 24)

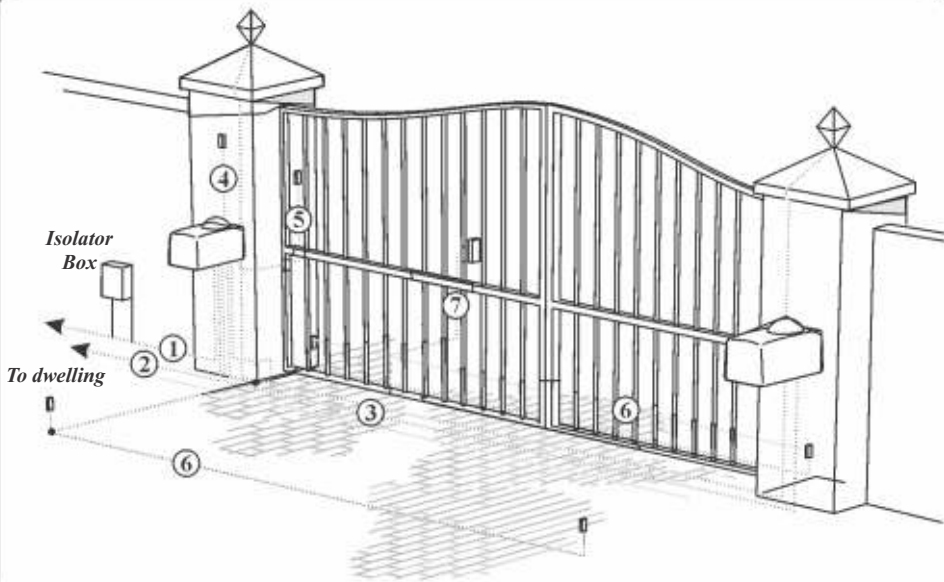

Figure 9 Cabling Requirements

CABLE REQUIREMENTS

1. 220V AC mains cable (3 core LNE 0,5mm²)*†, via mains isolator switch
Or
Low voltage 16V AC battery charger supply (2 core 1,5mm²)†.
2. Intercom cable (n1 + 6 core) to house.
3. Slave motor cable (if required) (3 core 2,5mm² + 3 core 0,5mm² multistranded).
4. Radio receiver cable (3 core 0,5mm² multistranded).
5. Pedestrian key switch (if required) (2 core 0,5mm² multistranded).
6. Infrared beams or safety edge (if required) (3 core 0,5mm² multistranded).
7. Intercom cable (n2+2 core 0,5mm² multistranded) to gate station.

n1 = number of cores required by intercom.

n2 = number of cores required by intercom.

* Increase cable thickness if pillar lights are to be installed.

† Screened cable is always recommended to provide better protection against lightning - earth one end of screening.

2 SET UP THE GATE ORIGIN

- Release the manual override and close the gate(s).
- Use the origin tool and line up marks as in figure 10. (IM page 28)
- Open gate 1/2 way and **unscrew** the manual release mechanism. (IM page 28).

SETTING THE GATE ORIGIN

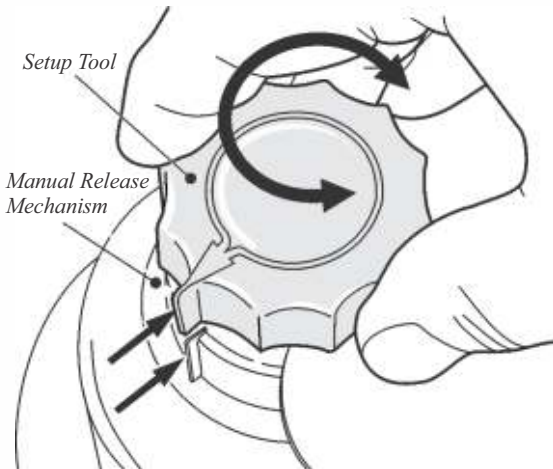

Figure 10 Origin Setup

3 GET INTO PROGRAMMING MODE

- Remove all power. (*IM* page 28)
- Fit the SET link.
- Reapply power

4 SELECT EITHER MASTER OR SLAVE SETUP

- Press and hold the TEST button, release after 1 flash of L1.
- Then again, press and hold the TEST button, and release after 1 or 2 flashes of the STATUS LED. (1 Flash=master, 2 Flashes=slave) (*Installation Manual* page 29)

5 SET THE GATE LIMITS

- Press and hold TEST until the gate is closed, and then release.
- **NB: THE GATE MUST CLOSE. IF IT OPENS :**
 - Release the TEST button.
 - Swap the respective motor wires.
 - Press and hold TEST until gate is closed, and then release.
- Press and hold TEST until gate is open, and then release.
- Press and release TEST (When setting up the MASTER gate, it will close and then open to pedestrian. *IM* page 29).
- If setting up the master gate, press and release TEST once more to complete the setup (The MASTER gate will open fully, and the SLAVE gate will move slightly).

6 SETTING ADDITIONAL FEATURES (OPTIONAL)

- Determine what features are required (See Table 2). (*IM* page 47)
- Get into programme mode (as in Step 3), or continue from Step 5.
- **To select the Feature to Change: (*IM* page 31)**
 - **Press and hold** the TEST button while monitoring L1:

Example of how to select the AUTOCLOSE feature:

The L1 light will flash once and pause,

Then flash twice and pause ...

- At this moment release the TEST button to select feature number 2. (L2 will turn off, and L1 will keep on flashing 2 times and pausing to indicate that feature number 2 is selected).



NOTE: The STATUS of the Feature is not changed yet, the feature has only been selected to be changed!

If an incorrect Feature is selected, then remove and re-apply power and repeat the procedure.

- **To change the STATUS value of a Feature: (IM page 31)**

Press and hold the TEST button while monitoring the STATUS light:

(Continues from above example to set outoclose to ON status).

The L1 light will flash once and pause,

At this moment **release the TEST** button to give a STATUS value of 1. The AUTOCLOSE feature has been set to ON



NOTE: Only after setting the STATUS, would the AUTOCLOSE be turned ON.

(L2 will come back on, indicating that the STATUS has been set.)

- **To change the COUNT value of a Feature: (IM page 31)**

Press and hold the TEST button while monitoring the STATUS light:

After a slight pause, the STATUS light will start flashing regularly:

Flash (1), Flash (2), Flash (3), Flash (4), Flash (5),
Flash (6) Flash (9), Flash (10).

At this moment release the TEST button to give a COUNT value of 10. This could for example be the preflash time.

(L2 will come back on, indicating the COUNT value has been set).

7 EXIT PROGRAMMING MODE

- Remove the SET link.

CP75 CONTROLLER FUNCTIONS

FEATURE		STATUS or COUNT		
DESCRIPTION	FEATURE NUMBER	STATUS VALUE	COUNT VALUE	DESCRIPTION
Gate Limit Settings	1	-	-	See detailed instructions on page 29
Auto-close	2	1	-	ON
		2	-	OFF (Default)
Auto-close Time	3	-	1 Flash = 1 second	15 seconds (Default)
Mode of Operation	4	1	-	STANDARD (Default)
		2	-	CONDOMINIUM
		3	-	PIRAC
		4	-	REVERSING
Pedestrian Auto-close	5	-	1 Flash = 1 second	5 seconds (Default)
Courtesy Light	6	-	1 Flash = 10 seconds	120 seconds (Default)
Collision Sensitivity	7	1	-	HIGH (Default)
		2	-	MEDIUM
		3	-	LOW
Auto-close Override	8	-	1 Flash = 1 second	3 second (Default)
Positive Close Mode	9	1	-	ON
		2	-	OFF (Default)
Preflashing	10	1	-	MODE 1
		2	-	MODE 2
		3	-	MODE 3
		4	-	OFF (Default)
Preflash Time	11	-	1 Flash = 1 second	2 seconds (Default)
Collision Counter	12	-	1 Flash = 1 count	4 counts (Default)
Leaf Delay Select	13	1	-	Delay on slave opening
		2	-	Delay on master closing
		3	-	Delay on slave opening & master closing
		4	-	Delay off (Default)
Leaf delay time / Solenoid Strike Time	14	-	1 Flash = 1 second	2 seconds (Default)

Table 2 Controller Functions Menus and Submenus

CP75 BASIC CONTROLLER CONNECTIONS

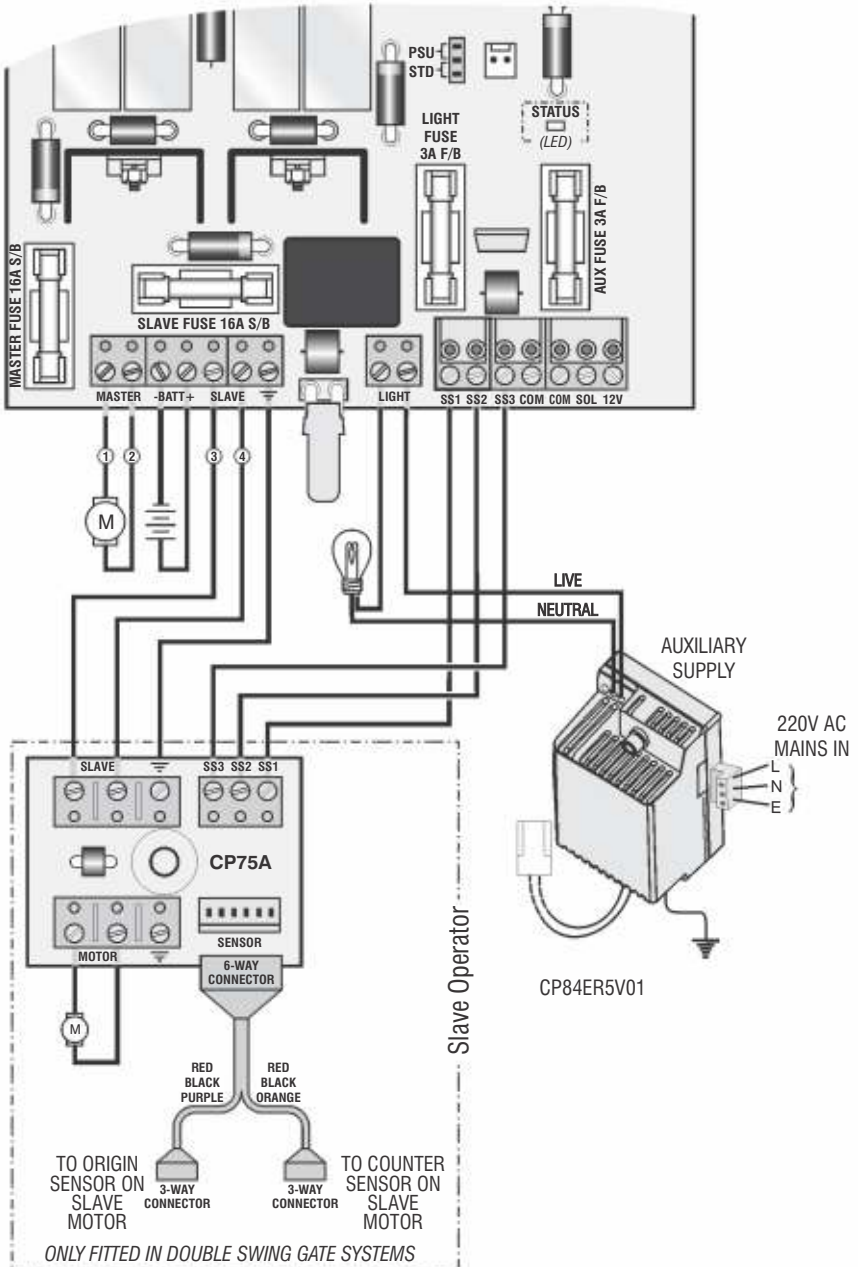
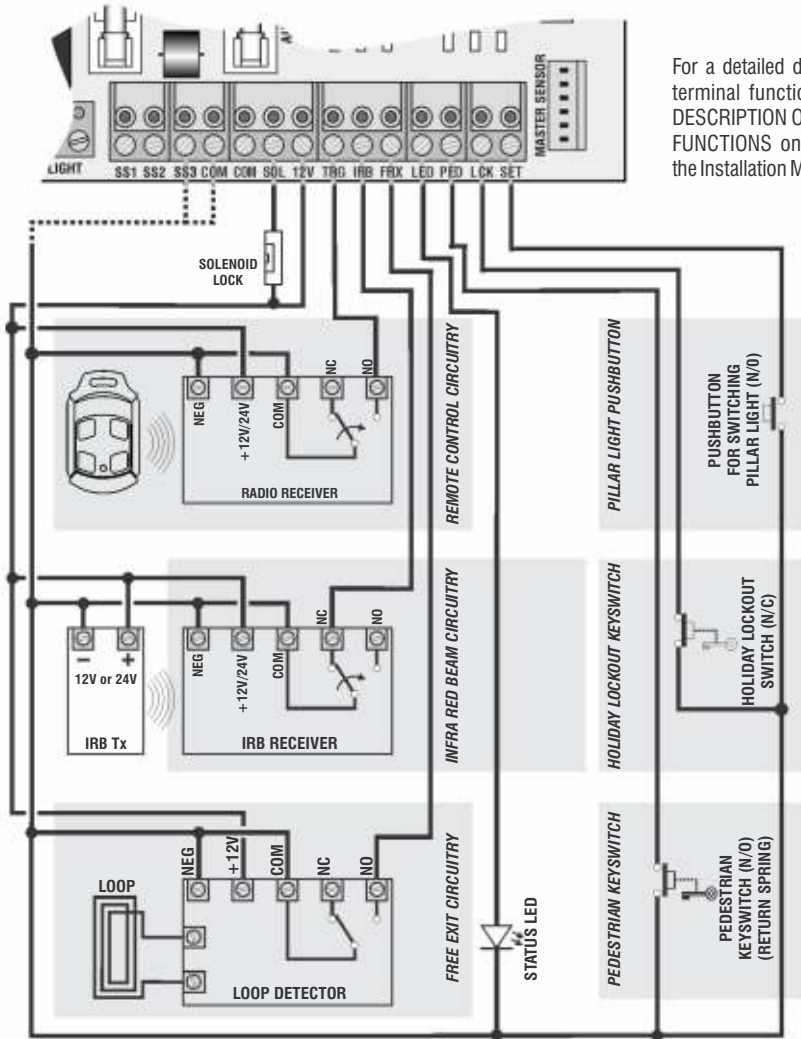

Figure 11 CP75 Controller Connections

TRIGGER CONNECTIONS



For a detailed description of terminal functions, refer to DESCRIPTION OF TERMINAL FUNCTIONS on page 45 of the Installation Manual.

Figure 12 CP75 Controller Trigger Connections

8 PERFORM INSTALLATION HANDOVER

- Explain to the user how to **SAFELY** operate the gate. (IM, page 51.)