

D5 Evo Sliding Gate Operator Installation Manual

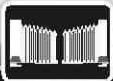

SLIDING GATE OPERATORS



SWING GATE OPERATORS



GARAGE DOOR OPERATORS



REMOTE CONTROLS



INTERCOMS



SAFETY BEAMS



KEYPADS



Company Profile



1986



1990



1995



1999



Centurion Systems
Today

**In-house
R & D
development
team**



**Manufacture to
international
quality standard
ISO 9001:2000**



Oas
INTERNATIONAL
ISO 9001:2000

**100%
testing of
products**



**Competent
after-sales
technical support**



**Sales and support throughout
Southern Africa and over
50 countries worldwide**

CENTURION SYSTEMS (Pty) Ltd. reserves the right to make changes to the products described in this manual without notice and without obligation of CENTURION SYSTEMS (Pty) Ltd. to notify any persons of any such revisions or changes. Additionally, CENTURION SYSTEMS (Pty) Ltd. makes no representations or warranties with respect to this manual.

No part of this document may be copied, stored in a retrieval system or transmitted in any form or by any means electronic, mechanical, optical or photographic, without the express prior written consent of CENTURION SYSTEMS (Pty) Ltd.



Contents



Mechanical Setup	page 1
Electrical Setup	page 2
Commissioning and Handover	page 2



IMPORTANT SAFETY INSTRUCTIONS	page 3
--------------------------------------	--------

1. Section left blank for future use	page 5
2. General description	page 6
Lightning protection	page 6
Theft protection	page 6
3. Specifications	page 7
Physical dimensions	page 7
Technical specifications	page 7
Fuse protection	page 8
4. Icons used in this booklet	page 8
5. Product identification	page 9
6. Required tools and equipment	page 10
7. Preparation of site	page 11
8. Cabling requirements	page 14
9. Lubrication	page 15
10. Operator installation	page 16
11. Electrical setup	page 28
12. Wiring diagram for closing safety beam	page 29
13. Wiring diagram for opening safety beam	page 30
14. Wiring diagram for external radio receiver and loop detector	page 31
15. Wiring diagram for other inputs	page 32
16. Mains supply, battery, charger and pillar light connections	page 33
17. Earthing for effective lightning protection	page 34
18. Commissioning the system	page 35
Setting the gate limits	page 35
19. How to set up additional features on the D5 - Evo controller	page 36
20. Menu navigation map	page 37
21. Controller features	page 40
22. Factory defaults schedule	page 51
23. Description of terminal functions	page 53
24. Diagnostics	page 56
Diagnostic LEDs	page 56
Gate status LED	page 56
LCD display	page 57
Buzzer feedback	page 58
25. Fault-finders guide	page 59
26. Manual operation	page 63
Manual release operation	page 63
Manual release latching	page 63
27. Installation Handover	page 64



Mechanical setup

These abbreviated instructions are for the experienced installer who needs a checklist to get a standard installation up and running in the minimum of time.

Detailed installation features and functions are referred to later in this manual.



Heed necessary site considerations page 11



Check cabling requirements page 14



Gather required tools and equipment page 10



Secure foundation plate page 19



Add oil to gearbox page 15



Mount gearbox page 20



Mount rack page 21



Mount origin marker page 25



Apply warning decals page 27

Electrical setup



Connect all wiring

page 28



Commissioning and handover



Set gate end-of-travel limits

page 35



Set additional features via the menus, if required

page 36



Carry out professional handover to client

page 64

FAST TRACK





IMPORTANT Safety Instructions

ATTENTION

To ensure the safety of people, it is important that you read all the following instructions. Incorrect installation or incorrect use of the product could cause serious harm to people.

The installer, being either professional or DIY, is the last person on the site who can ensure that the operator is safely installed, and that the whole system can be operated safely.

Warnings for the installer

CAREFULLY READ AND FOLLOW ALL INSTRUCTIONS before beginning to install the product.

- All installation, repair, and service work to this product must be carried out by a suitably qualified person
- Do not activate your gate opener unless you can see it and can determine that its area of travel is clear of people, pets, or other obstructions
- **NO ONE MAY CROSS THE PATH OF A MOVING GATE.** Always keep people and objects away from the gate and its area of travel
- **NEVER LET CHILDREN OPERATE OR PLAY WITH THE GATE CONTROLS**
- Secure all easily accessed gate opener controls in order to prevent unauthorized use of the gate
- Do not in any way modify the components of the automated system
- Do not install the equipment in an explosive atmosphere: the presence of flammable gasses or fumes is a serious danger to safety
- Before attempting any work on the system, cut electrical power to the operator and disconnect the batteries
- The mains power supply of the automated system must be fitted with an all-pole switch with contact opening distance of 3mm or greater. Use of a 5A thermal breaker with all-pole circuit break is recommended
- Make sure that an earth leakage circuit breaker with a threshold of 30mA is fitted upstream of the system
- Never short circuit the battery and do not try to recharge the batteries with power supply units other than that supplied with the product, or by Centurion Systems
- Make sure that the earthing system is correctly constructed, and that all metal parts of the system are suitably earthed

- Safety devices must be fitted to the installation to guard against mechanical movement risks, such as crushing, dragging and shearing
- It is recommended that at least one warning indicator light be fitted to every system
- Always fit the warning signs visibly to the inside and outside of the gate
- The installer must explain and demonstrate the manual operation of the gate in case of an emergency, and must hand the User Guide over to the user
- Explain these safety instructions to all persons authorized to use this gate, and be sure that they understand the hazards associated with automated gates
- Do not leave packing materials (plastic, polystyrene, etc.) within reach of children as such materials are potential sources of danger
- Dispose of all waste products like packaging materials, worn out batteries, etc. according to local regulations
- Always check the obstruction detection system, and safety devices for correct operation
- Centurion Systems does not accept any liability caused by improper use of the product, or for use other than that for which the automated system was intended
- This product was designed and built strictly for the use indicated in this documentation. Any other use, not expressly indicated here, could compromise the service life/operation of the product and/or be a source of danger

Everything not expressly specified in these instructions is not permitted.

WARNING! WARNING! WARNING! WARNING! WARNING!



KEEP CLEAR!
GATE MAY MOVE AT ANY TIME!





MOVING GATE CAN CAUSE SERIOUS INJURY OR DEATH!
KEEP CLEAR! GATE MAY MOVE AT ANY TIME!
DO NOT ALLOW CHILDREN TO PLAY IN AREA
OR OPERATE GATE.

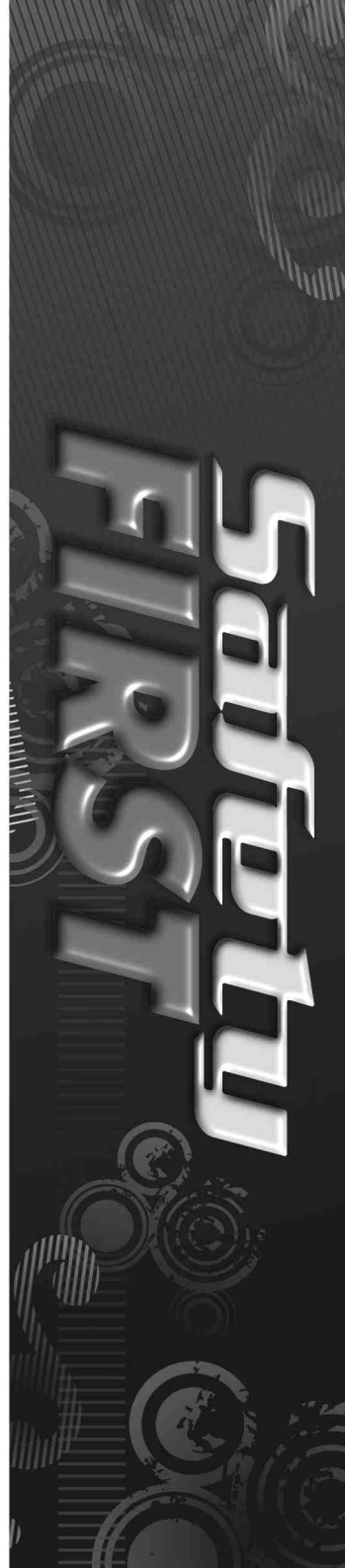

1. Section left intentionally blank

Please note that this page has been left blank intentionally, and will be updated in the near future.

2. General description

The D5 - Evo is a domestic and light-industrial operator designed to open and close sliding gates weighing up to 500kg. A custom designed gearbox moulded from robust engineering polymers, coupled to a powerful 12V DC motor, provides fast and reliable automation for entrances to homes and small housing estates.

The system operates off a 12V battery housed inside the operator using a switch mode charger to maintain the battery in a fully charged state. The battery provides critical power failure protection. A solar supply can be used as an alternative energy source to charge the battery.

Gate travel limits are managed by an opto-electronic system, comprising a gate mounted origin magnet and an internal rotary encoder. This system yields precise and repeatable control over gate position.

Advanced features of the D5 - Evo logic controller include:

- Interactive graphical user interface via a backlit LCD display
- Automated setup of gate endpoints (limits)
- Fail-safe collision detection and auto reverse (adjustable sensitivity)
- Smooth, adjustable start/stop (ramp up/ramp down)
- Multiple operational modes
- Selectable, adjustable autoclosing
- Pedestrian (partial) opening
- Positive close mode
- Independent safety inputs for opening and closing beams
- Automatic beam test for both open and closing beams
- Advanced beam alarm functions
- Advanced lightning/surge protection
- Timed courtesy light output
- Multiple pre-flashing modes
- Independently adjustable motor speed in both opening and closing directions
- Onboard NOVA rolling code (Keeloq™ encryption) radio receiver with full channel mapping capability (limited to 125 buttons)
- Onboard ChronoGuard timer (patent pending) for autoactivation of various physical input and outputs and time-barring of the same inputs and output including remote controls

Lightning Protection

The electronic controller utilizes the same proven surge protection philosophy that is used in all CENTURION products. While this does not guarantee that the unit will not be damaged in the event of a lightning strike or power surge, it greatly reduces the likelihood of such damage occurring. The earth return for the surge protection is provided via the mains power supply earth and/or earth spike located next to the operator.



In order to ensure that the surge protection is effective, it is essential that the unit is properly earthed.

Theft Protection

While care has been taken in the design of the D5 - Evo to prevent unauthorized removal (theft) of the unit, an optional steel theft-resistant cage is also available for added peace of mind.

3. Specifications

Physical dimensions

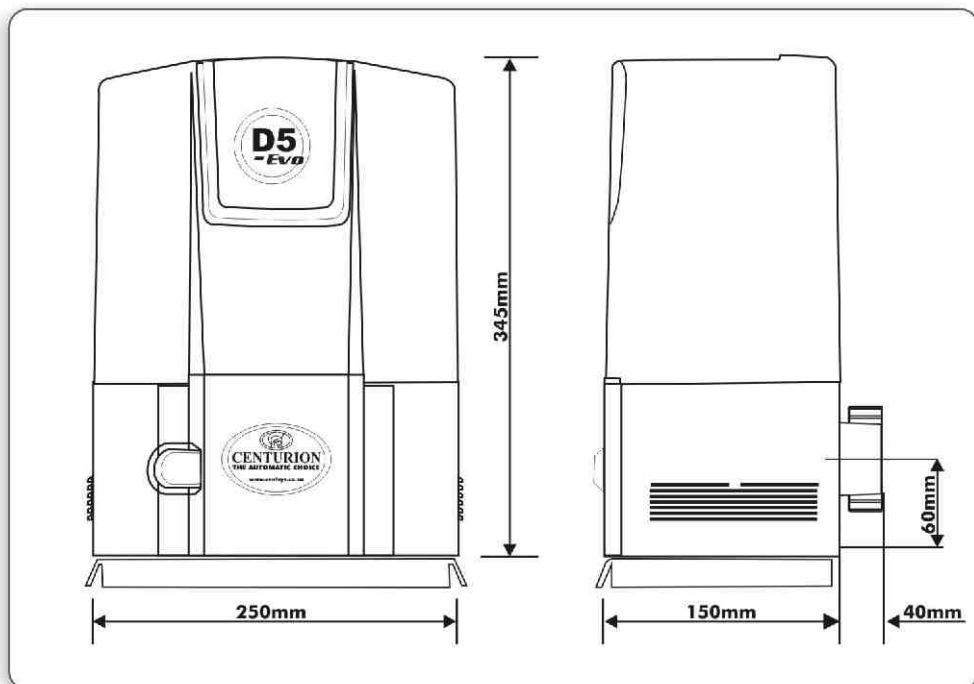

FIGURE 1. OVERALL DIMENSIONS

Technical specifications

Input voltage	220V \pm 10%, 50Hz
Motor voltage	12V DC
Motor power supply	Battery driven (standard capacity - 1 x 7Ah)
Battery charger	2A @ 14.2V (charging voltage 13.76V)
Current consumption (mains)	170mA
Current consumption (motor at rated load)	10A
Operator push force - starting	30kgf
Operator push force - rated	20kgf
Gate mass - maximum	500kg
Gate length - maximum	20m
Gate speed (varies with load)	18-22 m/min
Manual override	Lockable door with key release
Maximum numbers of operations per day	150

Duty cycle - mains present	50% [✧]
Operations in standby with 7Ah battery*	
half day	44
full day	35
Operations in standby with 35Ah battery*	
half day	150*
full day	150*
Collision sensing	electronic
Operating temperature range	-15°C to +50°C
Onboard receiver type	NOVA rolling code (Keeloq™ encryption) multichannel
Receiver code storage capacity	125 transmitter buttons
Receiver frequency	433MHz
Mass of unit packed (standard kit, excl. rack and battery)	13.5kg
Packing dimensions (standard kit, excl. rack and battery)	305mm long x 240mm wide x 430mm high

✧ Based on a push force of less than 50% of rated

* Limited by maximum daily usage

* Based on 4m gate, no accessories fitted, such as infrared beams

Fuse protection

The following protection fuses are provided on the system:

Item	Type	Rating
Main controller		
Motor circuit	Automotive fuse ATO (25 x 7mm)	30A
Light circuit	5 x 20mm	3A fast blow
Auxiliary supply	Resettable fuse	3A
Charger		
Mains input	5 x 20mm	3A fast blow*

*Not user serviceable

4. Icons used in this manual



This icon indicates tips and other information that could be useful during the installation.



This icon denotes variations and other aspects that should be considered during installation.



This icon indicates warning, caution or attention! Please take special note of critical aspects that **MUST** be adhered to in order to prevent injury.

6. Required tools and equipment

- Pull scale – 50kg
- Spanner – 17mm; 10mm
- Screwdriver – 3.5mm flat
- Allen key – 6mm; 4mm
- Crimping tool and pin lugs
- Side cutters
- Hacksaw
- Spirit level
- Measuring tape

If casting foundation plate into concrete:

- Pick
- Spade

If bolting foundation plate onto existing plinth:

- Drilling equipment
- Masonry bits to suit rawlbolts being used

If welding foundation plate and/or rack to gate:

- Welding equipment
- G Clamp, 6 inch x 2

If left hand side of gearbox is mounted close to a post:

- Socket wrench
- Extension piece
- 17mm socket

If fastening rack to gate:

- Drilling equipment
- TEK screw socket

7. Preparation of site

General considerations for the installation

- Always recommend the fitment of additional safety equipment such as safety edges and safety beams, for additional protection against entrapment or other mechanical risks
- Check that no pipes or electrical cables are in the way of the intended installation
- Check that enough space is available for the gate operator with the gate in the required open position
- Check for loose sandy soil if installing foundations, as the soil condition may require a larger foundation
- Never fit the operator on the outside of the gate, where the public has access to it

Install the gate operator only if:

- It will not pose a hazard to the public
- There is sufficient clearance to a roadway and/or public thoroughfares
- The installation will meet all municipal and/or local authority requirements once completed
- The gate mass, length and application is within the operator specifications
- The gate is in good working order, meaning:
 - That it moves freely
 - Does not move on its own if left in any position
 - It can be installed to have sufficient clearance between moving parts when opening and closing to reduce the risk of personal injury and entrapment
- Pushbuttons or keyswitches, when required, can be positioned so that the gate is in line of sight of the operator

Endstops

- Fit endstops capable of stopping the gate at rated speed. Refer to specifications at the beginning of this manual for the operating speed
- **Make $H > h$ to ensure gate will not jump over endstop**

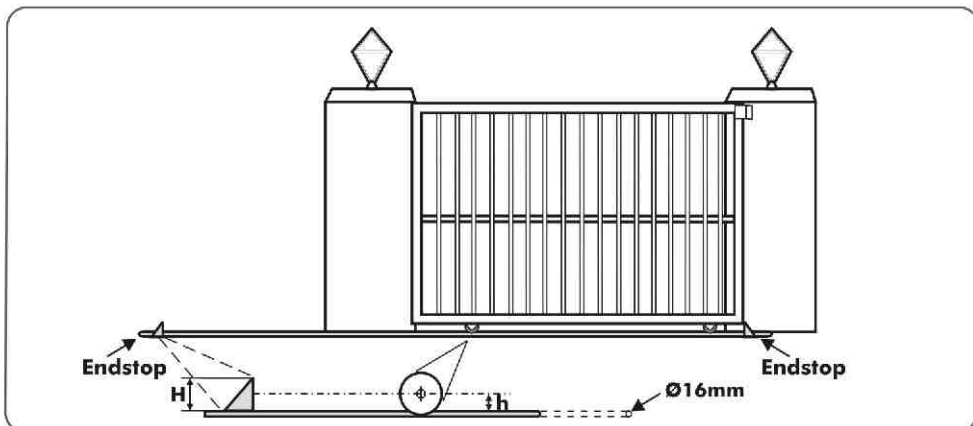

FIGURE 3. FITTING ENDSTOPS

WARNING!

Endstops are mandatory and must be fitted to prevent death or accidental injury should the gate overrun its limits



Guide rollers and anti-lift brackets

- Guide rollers must ensure that the gate is held vertically
- For improved safety, fit additional support post to prevent gate from falling over if guide rollers fail
- To prevent unauthorised access fit anti-lift brackets as shown
- The gap between the anti-lift bracket and the gate must be less than 5mm



Ensure that the gate cannot be lifted off the motor pinion with the anti-lift bracket fitted.

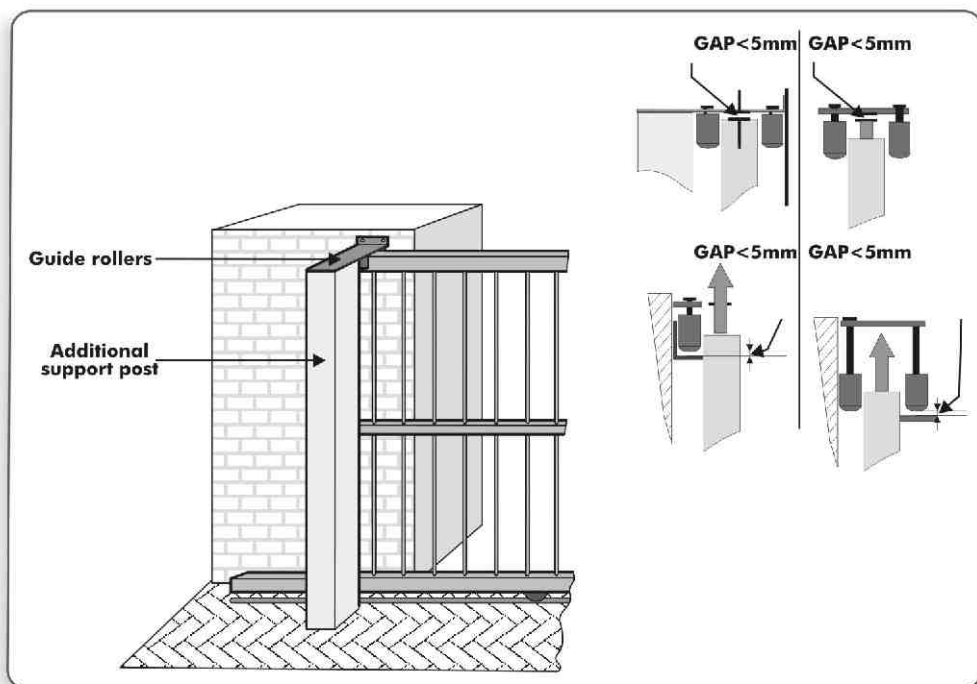

FIGURE 4. FITTING GUIDE ROLLERS

Starting and running forces

- Test the starting force of the gate as per the diagram. Use a pull scale to determine the maximum amount of pull force required to get the gate moving
- Determine the running force of the gate by continuing to pull on the scale with just sufficient force to keep it running and read off the maximum value in kgf shown on the scale
- Where possible determine the gate mass
- The CENTURION warranty will be void if the pull force and or gate mass, exceed the operator specification as below:
 - Starting force - 30kgf
 - Running (rated) force - 20kgf
 - Maximum gate mass - 500kg

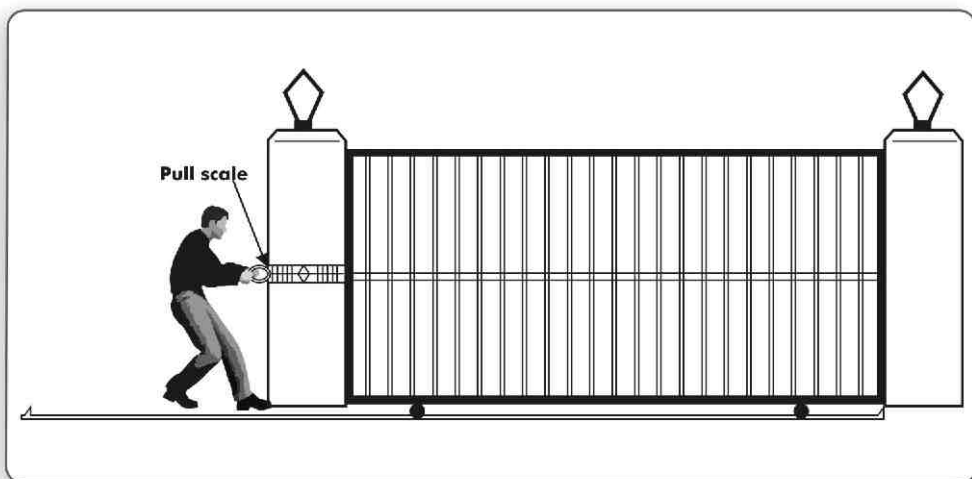

FIGURE 5. STARTING AND RUNNING FORCES

8. Cabling requirements

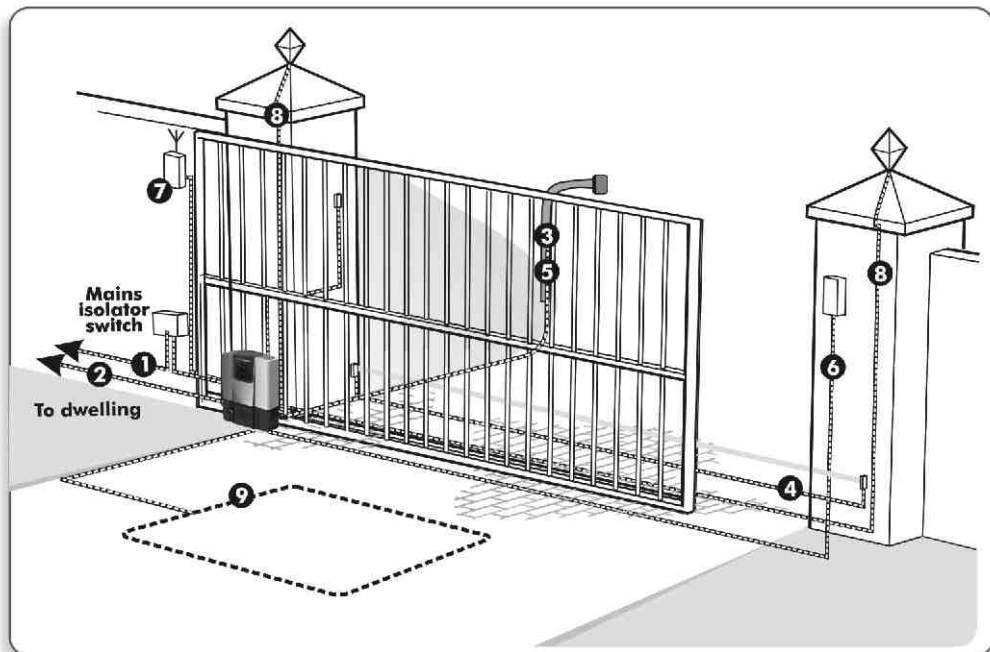

FIGURE 6. CABLING REQUIREMENTS

Legend

1. 220V AC mains cable via double pole mains isolator switch (3 core LNE 1.5mm² SWA)^{*☆}
2. Optional intercom cable from motor to dwelling (n1 + 6 core[☆] 0.5mm² multi-stranded)
3. Optional intercom cable from motor to entry panel (n2 0.5mm² multi-stranded)
4. Optional but recommended infrared safety beams (3 core 0.5mm² multi-stranded)
5. Optional access control device (3 core 0.5mm² multi-stranded)
- 6a. Optional pedestrian keyswitch (2 core 0.5mm² multi-stranded) OR
- 6b. Optional keypad (3 core 0.5mm² multi-stranded)
7. Optional external radio receiver (3 core 0.5mm² multi-stranded)[◇]
8. Optional pillar lights (3 core LNE SWA, size according to power requirements)
9. Optional ground loop for free-exit (1 core 0.5mm² multi stranded – silicone coated)^{*☆}

n1 = number of cores required by intercom

n2 = number of cores required by intercom

* Possibly increase cable thickness if pillar lights are installed

☆ Type of cable must adhere to municipal bylaws but typically SWA (steel wire armoured) cable is recommended. The armouring provides excellent screening, which gives better protection against lightning – earth one end of the screening)

◇ Allows for all features such as pedestrian opening, status LED etc., to be operated from the intercom handset inside the dwelling. Number of cores and type of cable could vary depending on brand of access control system being used

◇ For optimum range, an external receiver can be mounted on the wall

* Consult manufacturer of loop detector for specific details

9. Lubrication

Do not attempt to run the operator without first filling the gearbox with lubricant



- The internal gearset of the D5 - Evo is lubricated by means of an oil bath
- In order to prevent possible leakage during shipping, the unit is shipped with no oil inside the gearbox. A bottle containing 80ml of a special synthetic oil is included with the product, and this must be introduced **before** operating the product. (Product code: OIL80ML0X0/H)



It is more convenient to introduce oil before bolting the unit down, as shown in Figure 7.

The D5 - Evo does not require routine oil changes. However in the event of the unit losing oil due to stripping down or mechanical damage, the correct replacement oil is Castrol SAF X0 75W-90 synthetic final drive lubricant.



If the gearbox is bolted down in the horizontal position during filling, the correct level is reached when the oil level is in the flat section of the dipstick.

Emptying the 80ml bottle of oil provided will give sufficient oil.

Put 80ml oil in here
Oil specifications
Centurion product code: OIL80ML0X0/H

Look for COLOURED cap!

Oil filling procedure

1. Lift the cover of the operator
2. Remove the battery so that you can gain access to the coloured filler plug
3. Remove the coloured oil filler plug by levering it out with a screwdriver
4. Empty the contents of the oil bottle onto the gearbox (80ml)
5. Refit the coloured oil filler cap

Upright detail removed for clarity

FIGURE 7. OPERATOR LUBRICATION

10. Operator installation

Locate operator position

- To ensure operator does not protrude into driveway, install base plate at least flush with the driveway entrance
- Determine a suitable position and vertical height for the operator by considering Figures 8, 9 and 10
- It is typical to mount the rack above the pinion as shown in Figures 8A, 9A and 10A for each type of rack considered. However, in each case, Figures 8B, 9B and 10B show the rack mounted underneath

If there is space to mount the rack underneath without fouling the ground as the gate moves, the following are the pros and cons:

Pros

- The rack is more hidden from view
- It provides a very effective anti-lift bracket
- It ensures that as the gate beds in, the rack does not drop onto the pinion loading the operator unnecessarily

Cons

- Rack teeth face up vertically potentially collecting dirt
 - Custom bracket
-
- With careful selection of the rack configuration, and operator vertical height, mounting of the rack could in some cases be greatly simplified.
 - If a theft-resistant cage is required, be sure to leave enough clearance from pillars, etc.
 - If using nylon angle rack please ensure that the weight and pull force of the gate do not exceed the strength limit of the rack

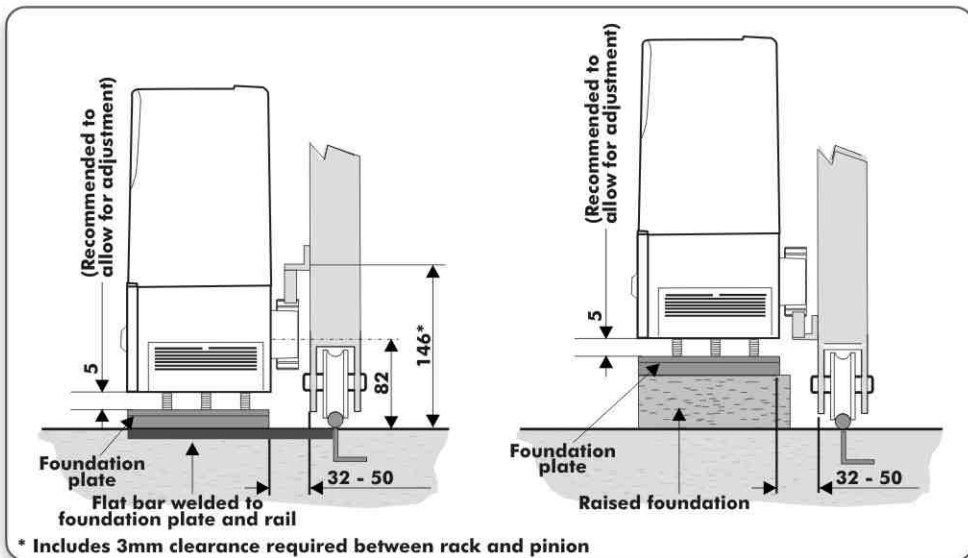

FIGURE 8A Steel rack, above pinion

FIGURE 8B Steel rack, below pinion

RAZ rack

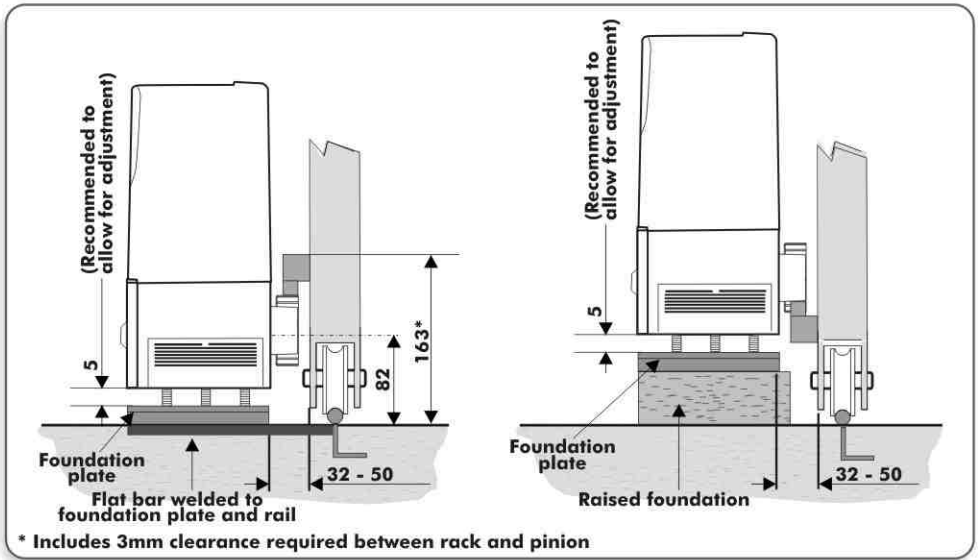

FIGURE 9A RAZrack, above pinion

FIGURE 9B RAZ rack, below pinion

Nylon angle rack

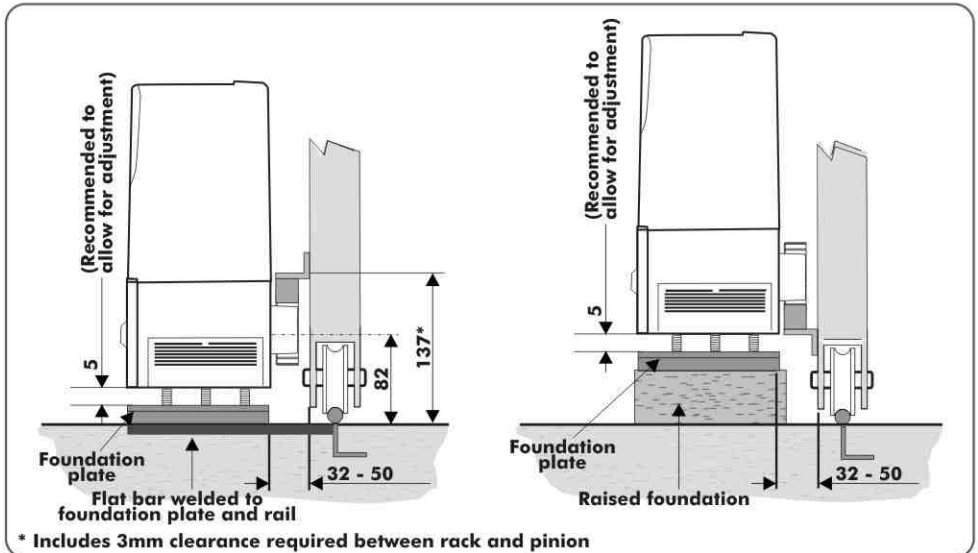

FIGURE 10A Nylon angle rack, above pinion

FIGURE 10B Nylon angle rack, below pinion

Foundation plate installation

1. The foundation plate can either be set into a concrete foundation, as in Figure 11 or bolted down onto an existing concrete plinth as in Figure 13.

Option 1: Concrete foundation

2. Assemble foundation plate with anchor brackets as shown.



- Ensure that the M10 gearbox mounting bolts are properly tightened
- Cable conduits must be installed before pouring the concrete (see next section)

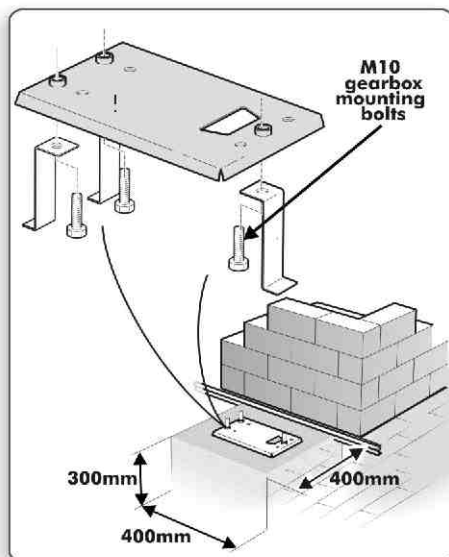

FIGURE 11



When using a concrete foundation it is recommended that the foundation plate is welded to the rail/track of the gate using short length of flat bar, as in Figure 12. This makes it possible to complete the whole mechanical and electrical installation, without having to wait for the concrete to set. After completing the installation the concrete can be poured and the operator left in the manual mode until the concrete has set.

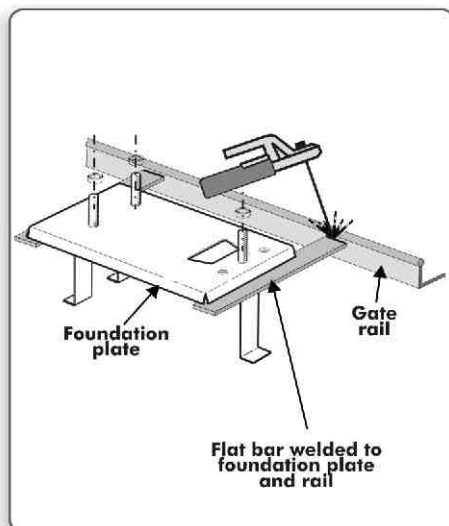

FIGURE 12

Option 2: Existing concrete plinth

3. If bolting onto an existing concrete plinth, place the foundation plate down in the correct position and use the plate as a template for marking the rawl bolt holes.
4. Assemble foundation plate without anchor brackets before bolting down onto plinth.



Ensure that the M10 gearbox mounting bolts are properly tightened.

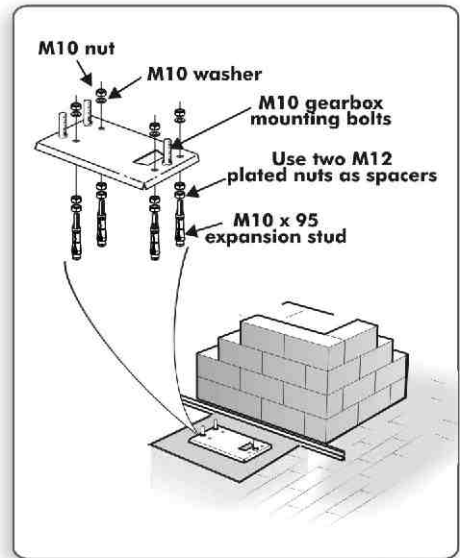

FIGURE 13

Route cables and secure foundation plate

1. Route cables as determined in Section 8, Cabling requirements.

2. Make sure that all cables and conduits protrude at least 400mm above the baseplate once installed as shown in Figure 14.



Make sure that the M10 bolts, which secure the gearbox, are in place.

3. Securely concrete or bolt the foundation plate in position.

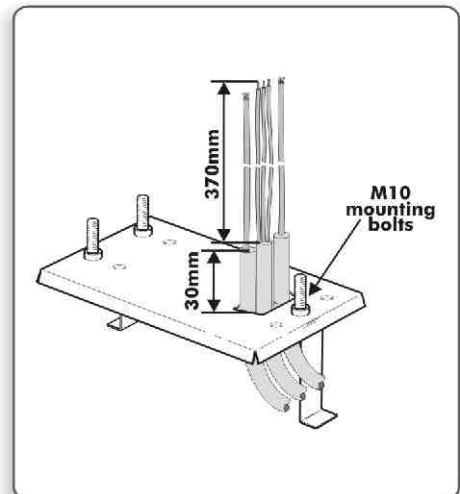

FIGURE 14

Mount the gearbox

1. Fit the M10 nuts and washers to the mounting bolts as shown in Figure 15.
2. Adjust the nuts to be 7mm clear from the base to allow for later adjustment.



Remember to fit the washers onto each nut before installing the gearbox.

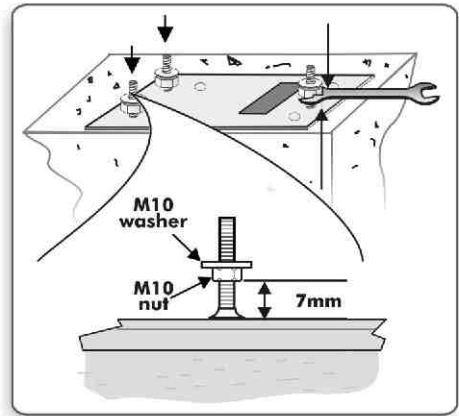

FIGURE 15

3. Remove the knock-outs for the cables from the gearbox.
4. Feed the cables through these holes while fitting the gearbox to the baseplate.
5. Note how the cables route up onto the control card.

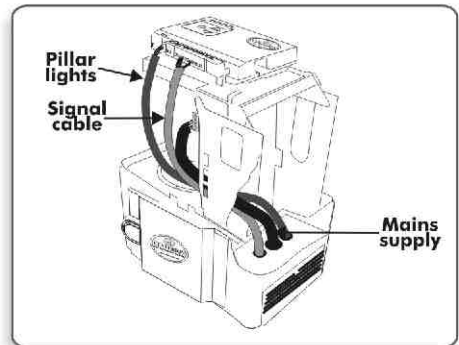

FIGURE 16

6. Check that the operator is level.
7. Secure the gearbox in place fitting a washer, spring washer and nut onto each gearbox mounting.
8. Seal the conduit and knock-out holes in the operator with silicone sealer to prevent ants from entering the operator through these cable entry points.

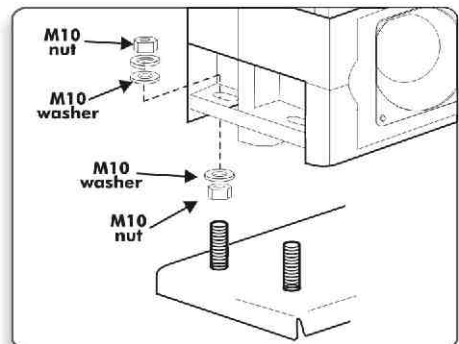

FIGURE 17

Mount the rack



The rack must be securely mounted to the side of the gate. It must be parallel with the gate rail, and there must be a 2 - 3mm gap between the teeth of the pinion of the rack, along the entire travel of the gate.

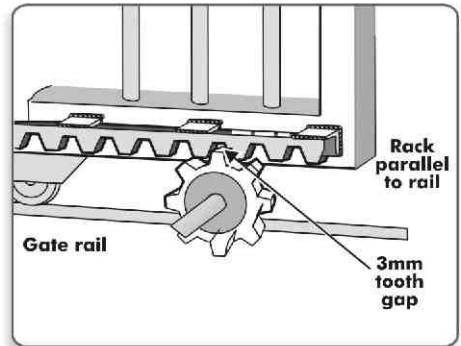

FIGURE 18



- Follow this procedure whether mounting steel, RAZ or nylon angle rack
- Refer to the sections that follow for specifics about the mounting of each type of rack

1. Before mounting the rack, raise the operator an additional 3mm.

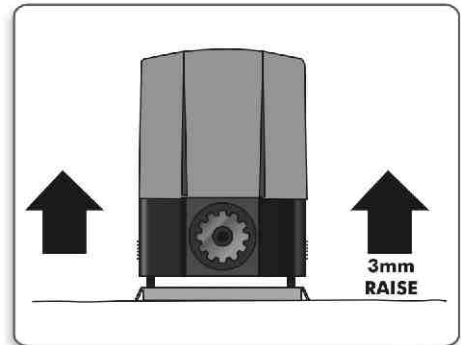

FIGURE 19

2. Put gearbox into manual mode. Refer to Section 26 for complete instructions.

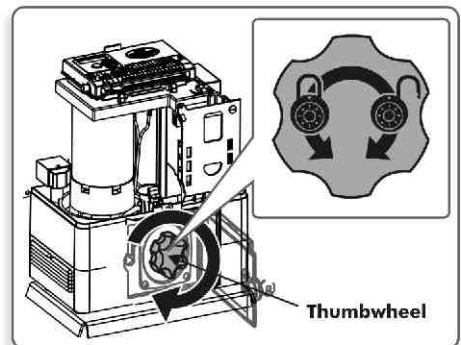

FIGURE 20

3. Start with the gate either fully open or closed.
4. Place the one end of the first section of rack on the pinion. Let it mesh fully.
5. Level the other end and fix that end to the side of the gate.

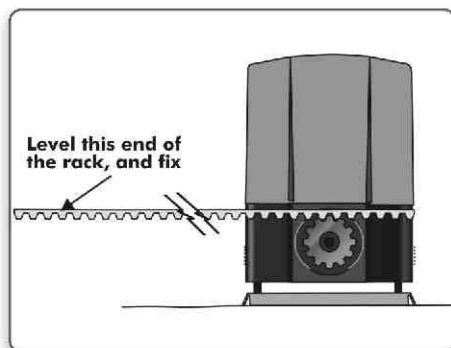

FIGURE 21



Refer to the sections that follow for instructions on how to fix the different types of rack.

6. Slide gate halfway along the first section.
7. Level the unsecured end, ensuring that the rack is resting on the pinion, not pressing down.
8. Before fully fixing each section of rack, slide gate backwards and forwards along the section, checking that the rack is only resting on the pinion, not pressing down.
9. Continue this way to fix all sections.

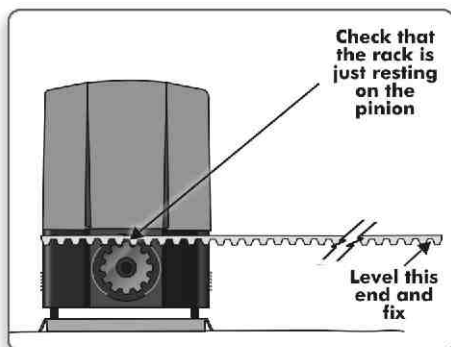

FIGURE 22



Refer to the sections that follow for instructions on how to join the different types of rack.

10. Finally lower the operator 3mm to achieve the required 3mm tooth clearance.
11. Ensure that operator mounting bolts are securely tightened.

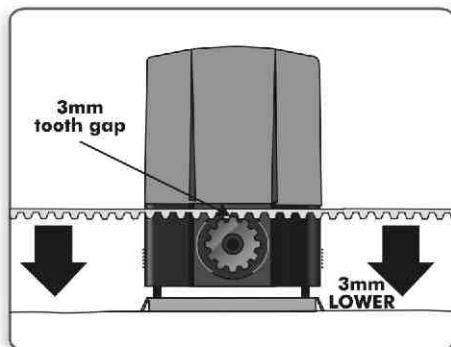

FIGURE 23

Steel rack

1. Fix rack using the steel angle brackets provided.
2. Brackets must be spaced no more than 300mm apart.

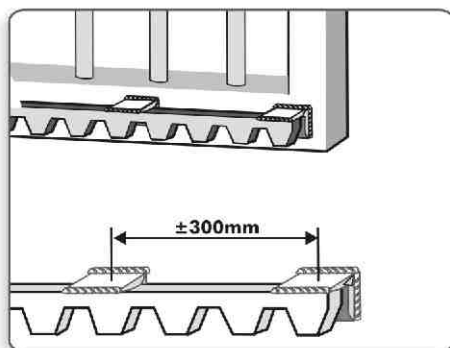

FIGURE 24

3. When joining different lengths of steel rack, a simple way of ensuring correct pitch spacing, is to clamp a small off-cut between the two pieces.

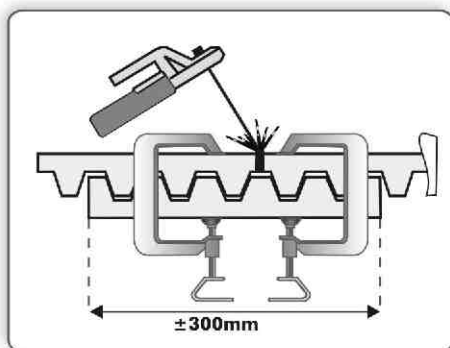

FIGURE 25

RAZ rack

1. Fix the RAZ rack to the side of the gate using the TEK screws provided. Use the vertical slots in order to allow adjustment.
2. Use at least three TEK screws per half metre section of rack.

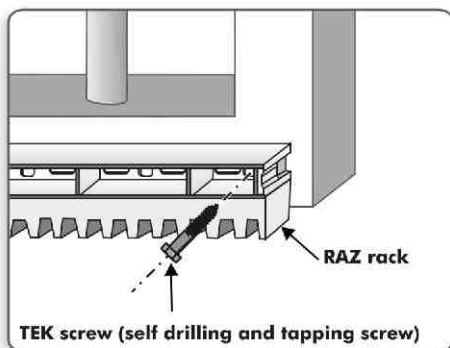

FIGURE 26

3. When fitting the RAZ rack it is easier to start on the right and work towards the left.
4. The RAZ rack simply clips together.

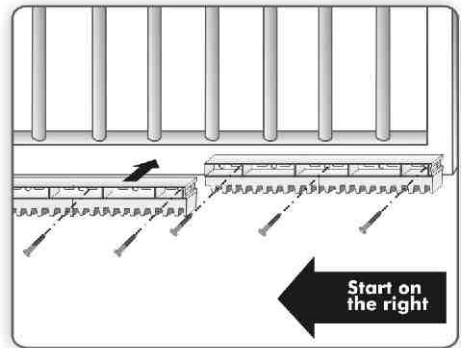

FIGURE 27A



Fit additional fixing screw through the horizontal slots to secure the rack to the gate directly above the pinion when the gate is in the closed, pedestrian and open positions.

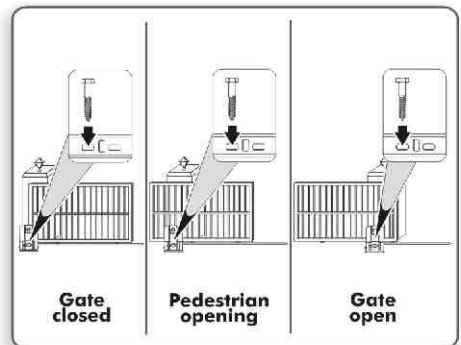

FIGURE 27B

Nylon angle rack

1. Fix rack to the side of the gate using the TEK screws.
2. Ensure that all the mounting holes provided in the angle section are used.

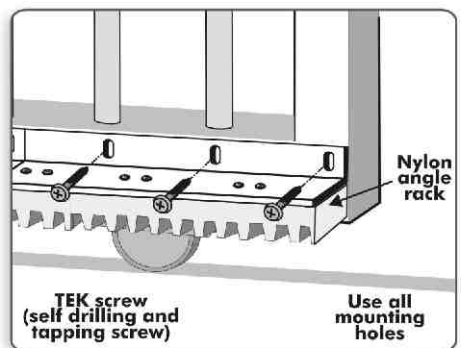

FIGURE 28

- When joining two lengths together, simply butt each section firmly together to ensure the correct pitch.

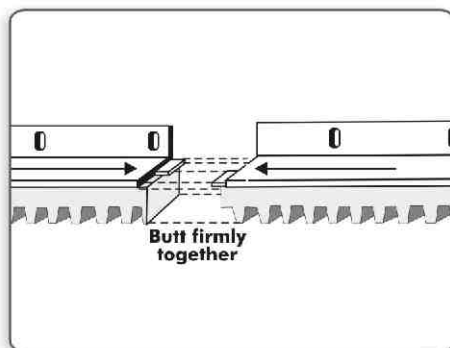

FIGURE 29

Mount the origin marker

- Close the gate completely.

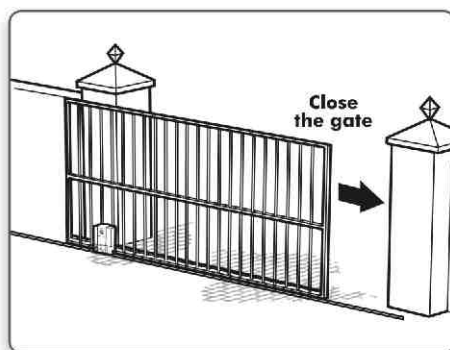

FIGURE 30

- Mount the origin marker to the rack a minimum of 500mm from the origin sensor. Refer to Figure 31, isometric view A or plan view B.



It is possible to make the distance between the marker and the sensor much greater than 500mm. However, if using the pedestrian opening facility, although the position of the marker will not affect the width of the pedestrian opening, it is preferable to have the marker mounted inside of the pedestrian opening point.

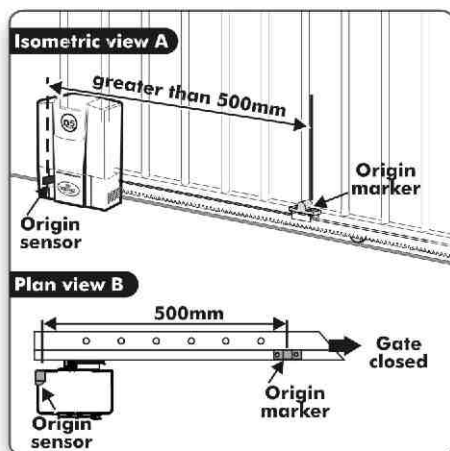

FIGURE 31

3. For steel rack mount the origin marker onto the rack using the bracket provided.
4. Weld the bracket to the rack.
5. Bolt the origin marker onto the bracket using the fasteners provided.

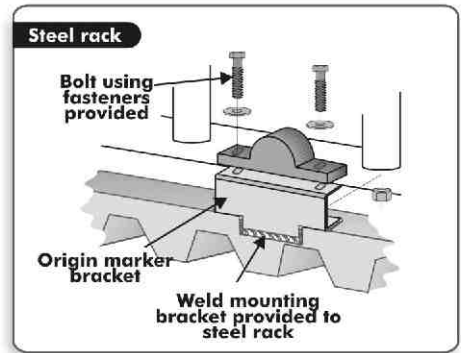

FIGURE 32

6. With the RAZ rack the origin marker mounts directly on top of the rack without a bracket.
7. Drill mounting holes directly into the rack and bolt into position.
8. File away the front lip of the rack if you need to move the origin marker closer to the operator as the gate slides past.

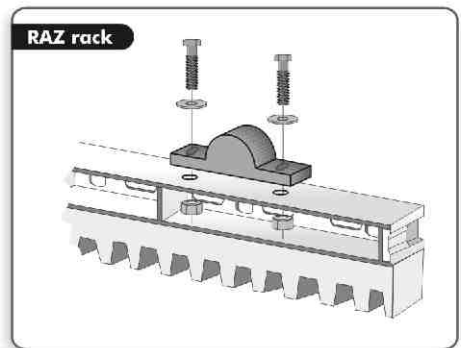

FIGURE 33

9. With nylon angle rack it is necessary to use the bracket provided.
10. It is preferable to use self-tapping fasteners to secure the bracket into the side of the nylon rack as shown.
11. Make a small tack weld to secure the back of the bracket onto the angle iron section of the rack.
12. Bolt the origin marker onto the bracket using the fasteners provided.

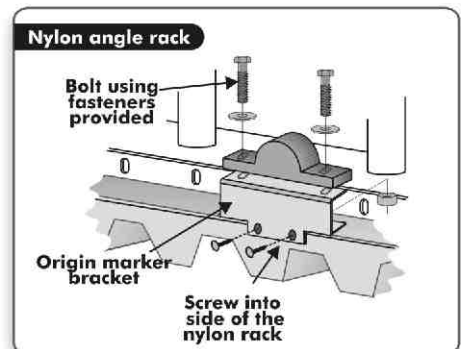

FIGURE 34

13. Note the orientation of the origin marker.

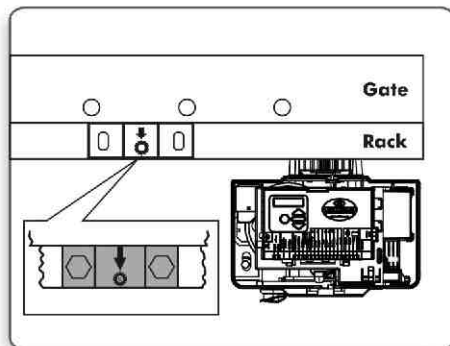

FIGURE 35

14. Manually slide the gate **open** until the origin marker is in line with the origin sensor.

15. Ensure distance between face of marker and front face of sensor is between 13 and 20mm.

16. Adjust distance by sliding the origin marker along the slotted mounting holes until the specified distance is achieved.

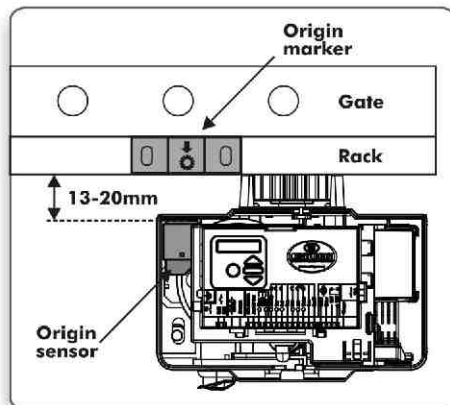

FIGURE 36



For best results, keep gap between marker and sensor as small as possible.

Apply warning decal

Apply the supplied warning decals to the gate as indicated on the reverse side of the decal.



11. Electrical setup

1. Always check that the circuit breaker in the electrical panel is in the OFF position, and that all high voltage circuits (more than 42.4V) are completely isolated from the mains supply before doing any work.
2. Ensure that all low voltage systems (less than 42.4V) are suitably protected from damage, by disconnecting all sources of power such as chargers and batteries before doing any work.
3. All electrical work must be carried out according to the requirements of all applicable local electrical codes. (It is recommended that a licensed electrical contractor perform such work.)



Connect all wiring

1. Connect all cables as required to the control card and battery charger, according to the wiring diagrams as shown in Sections 12 to 16 that follow.
2. Ensure that both the controller and the charger are effectively earthed for improved lightning protection. Refer to Section 17.
3. Check that the charger and battery are connected to the controller.



Ensure that the battery polarity is correct.

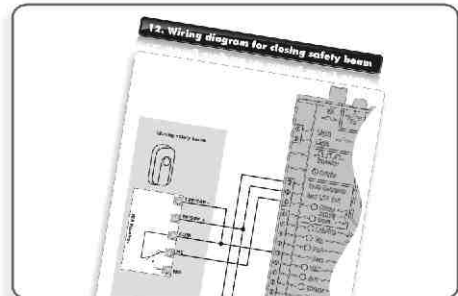

FIGURE 37

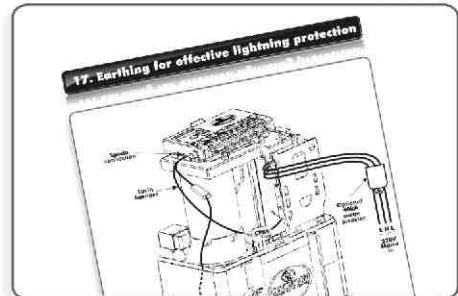

FIGURE 38

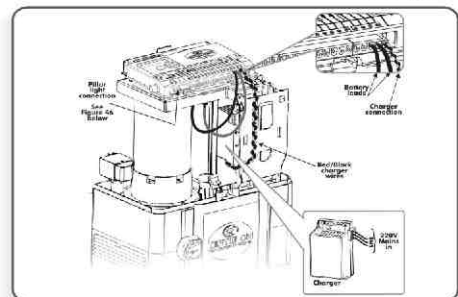

FIGURE 39

12. Wiring diagram for closing safety beam

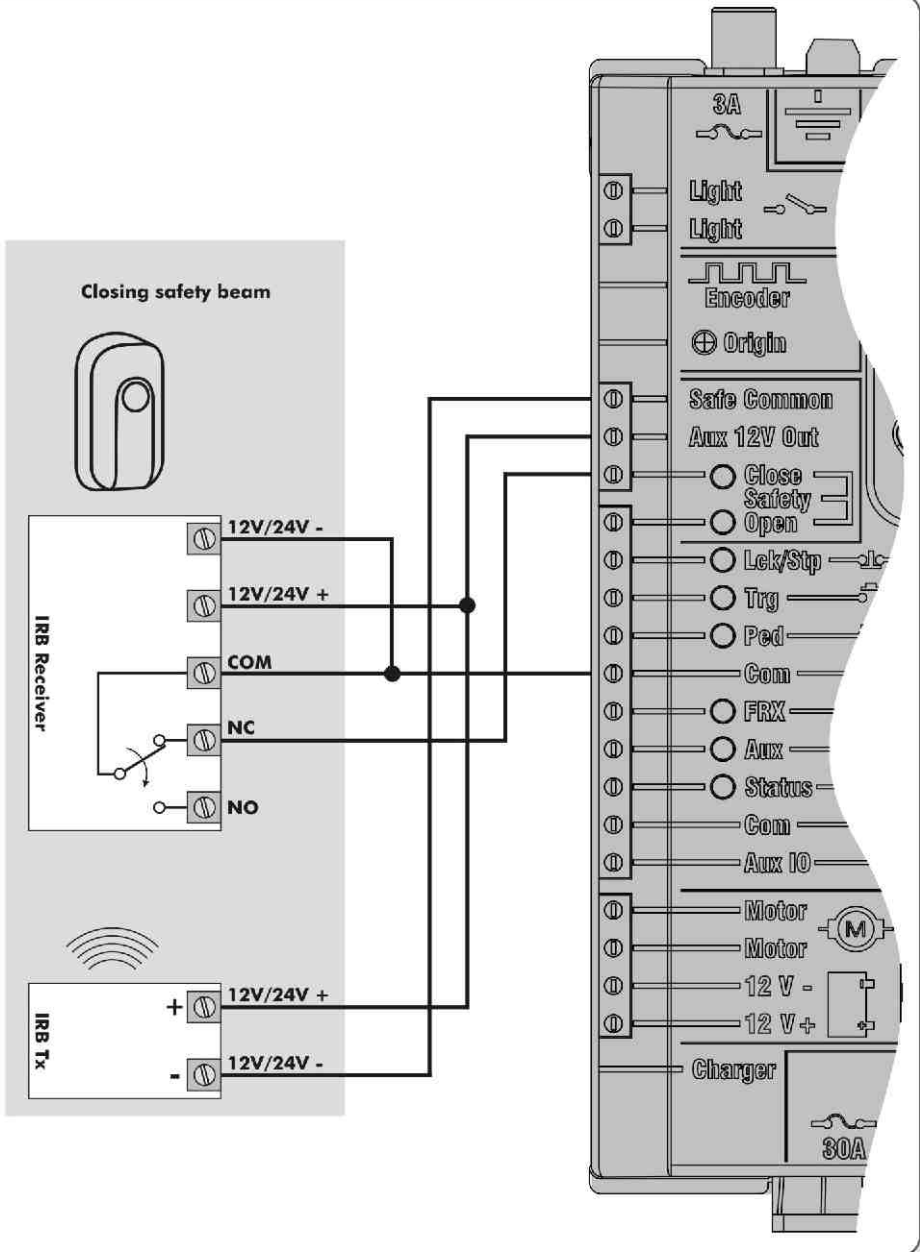

FIGURE 40

13. Wiring diagram for opening safety beam

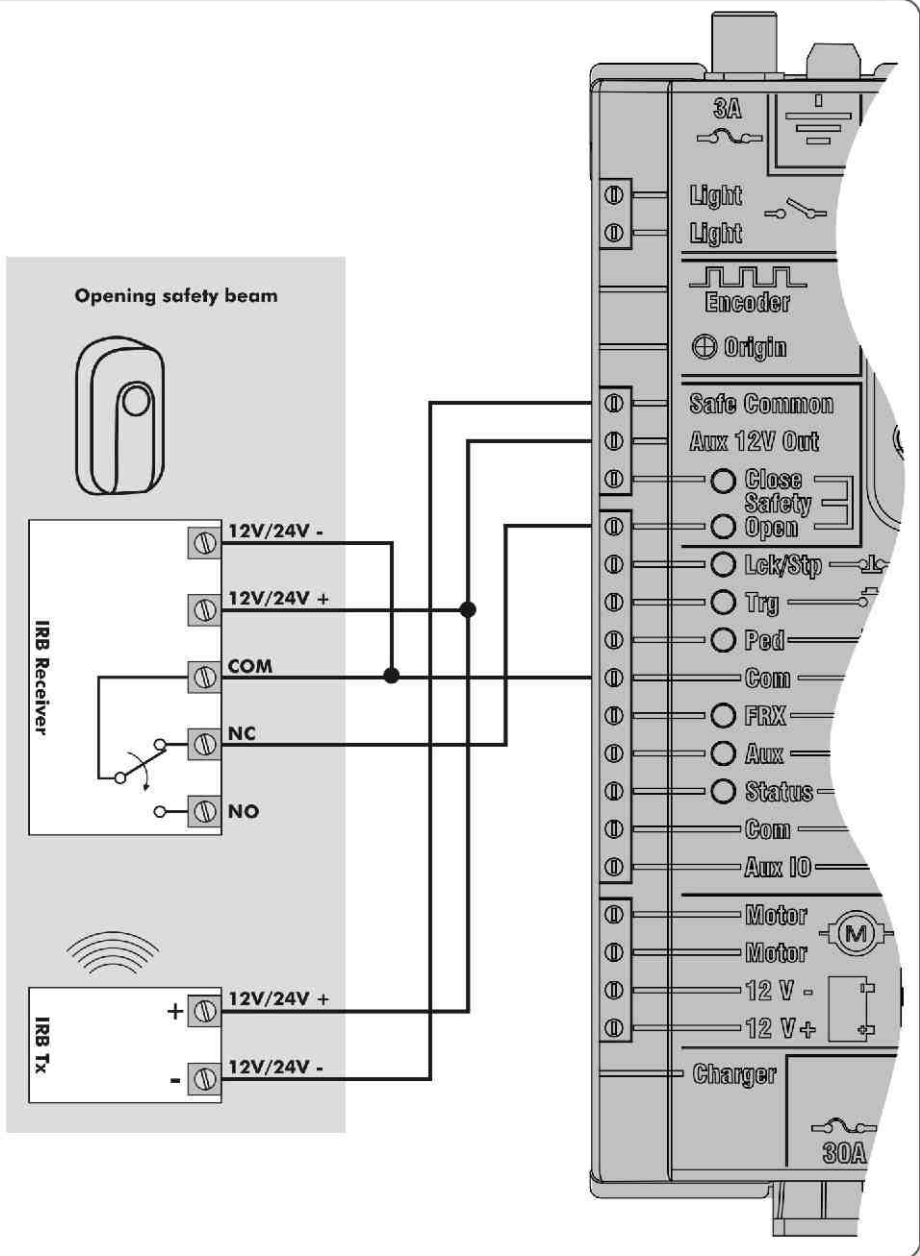
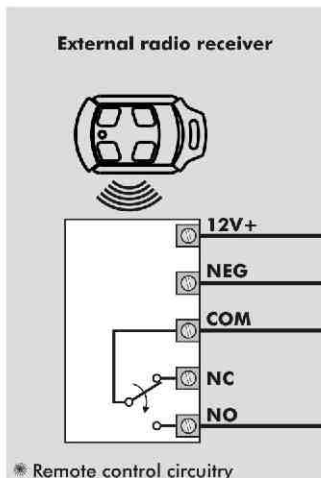
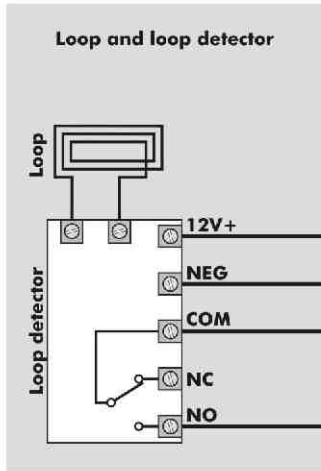
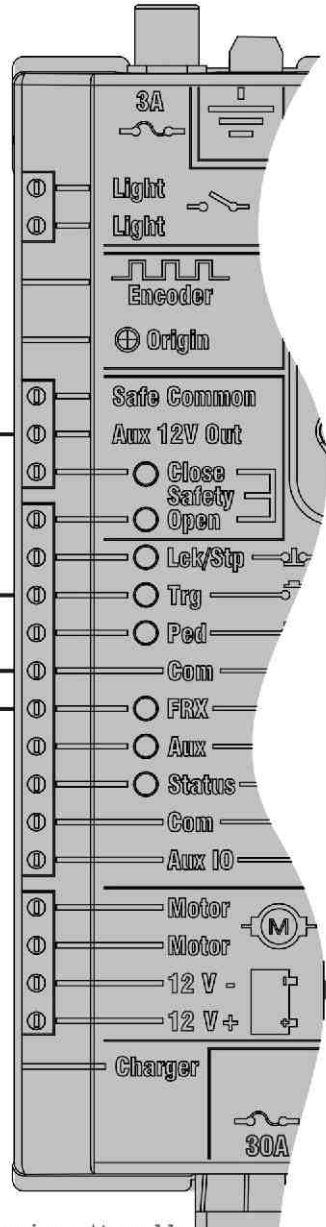

FIGURE 41

14. Wiring diagram for external radio receiver and loop detector



* Remote control circuitry



* Refer to diagram only if external receiver is being used and not the onboard receiver, disable onboard receiver - Menu 11

FIGURE 42

15. Wiring diagram for other inputs

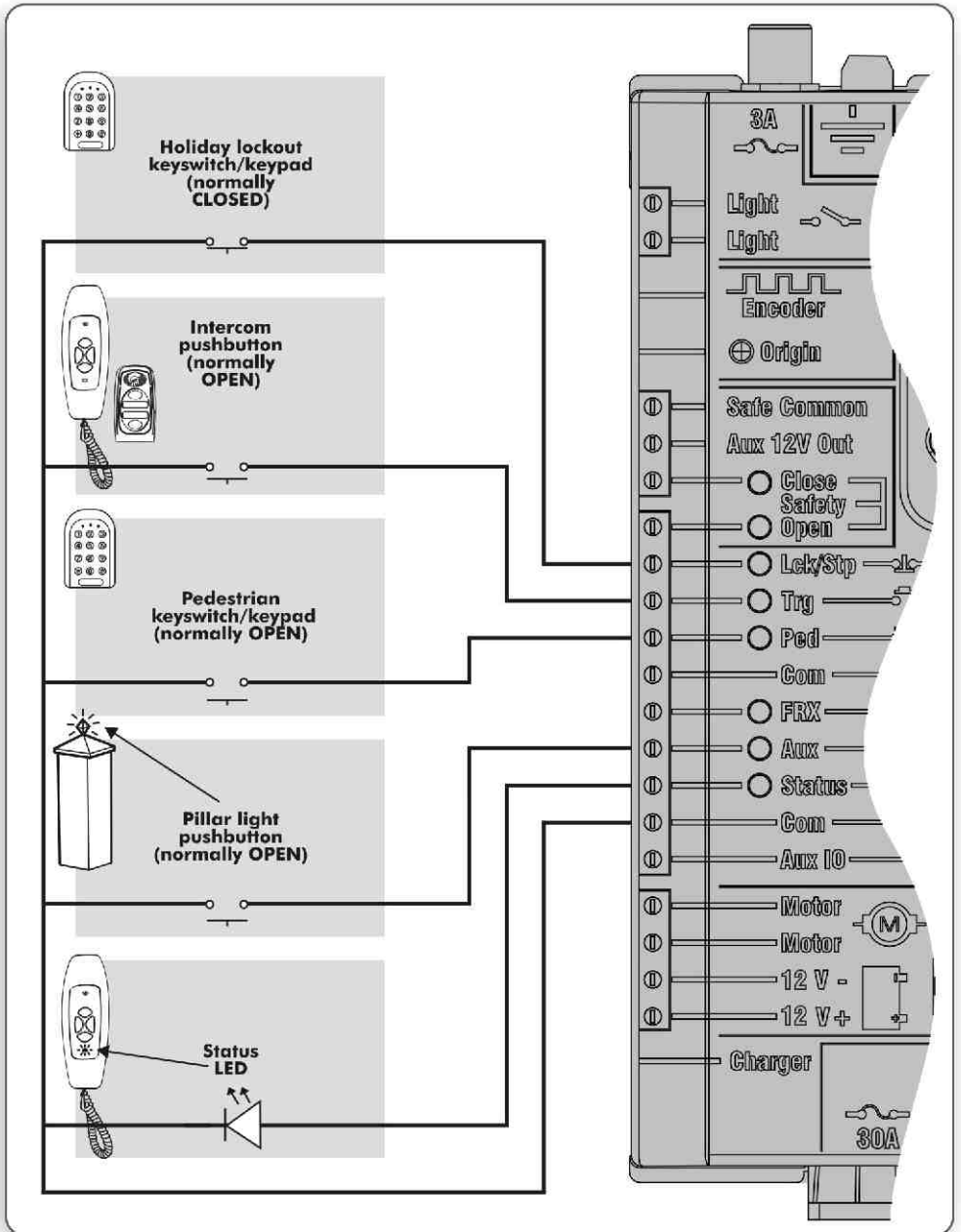

FIGURE 43

16. Mains supply, battery, charger and pillar light connections

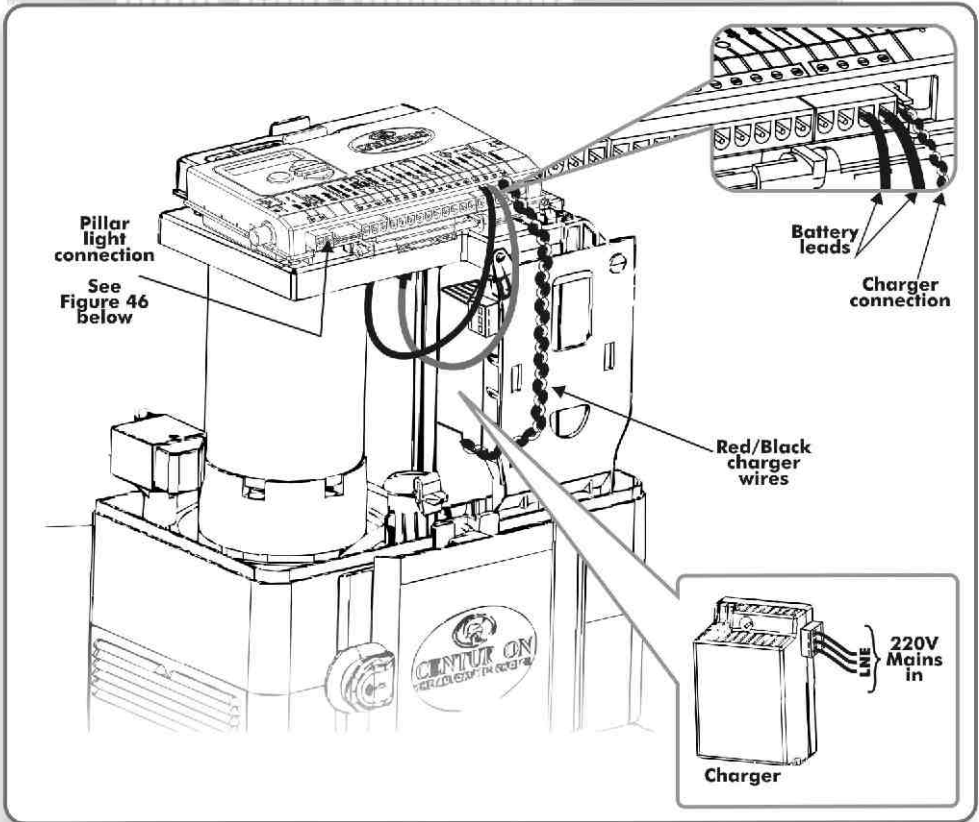

FIGURE 44

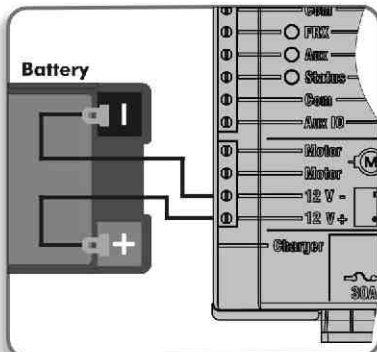

FIGURE 45. SCHEMATIC OF BATTERY CONNECTION

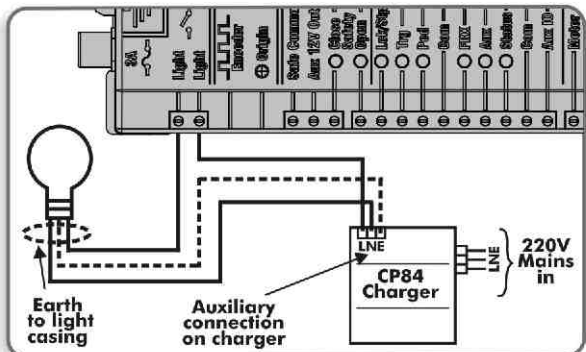

FIGURE 46. SCHEMATIC OF LIGHT CONNECTION

17. Earthing for effective lightning protection

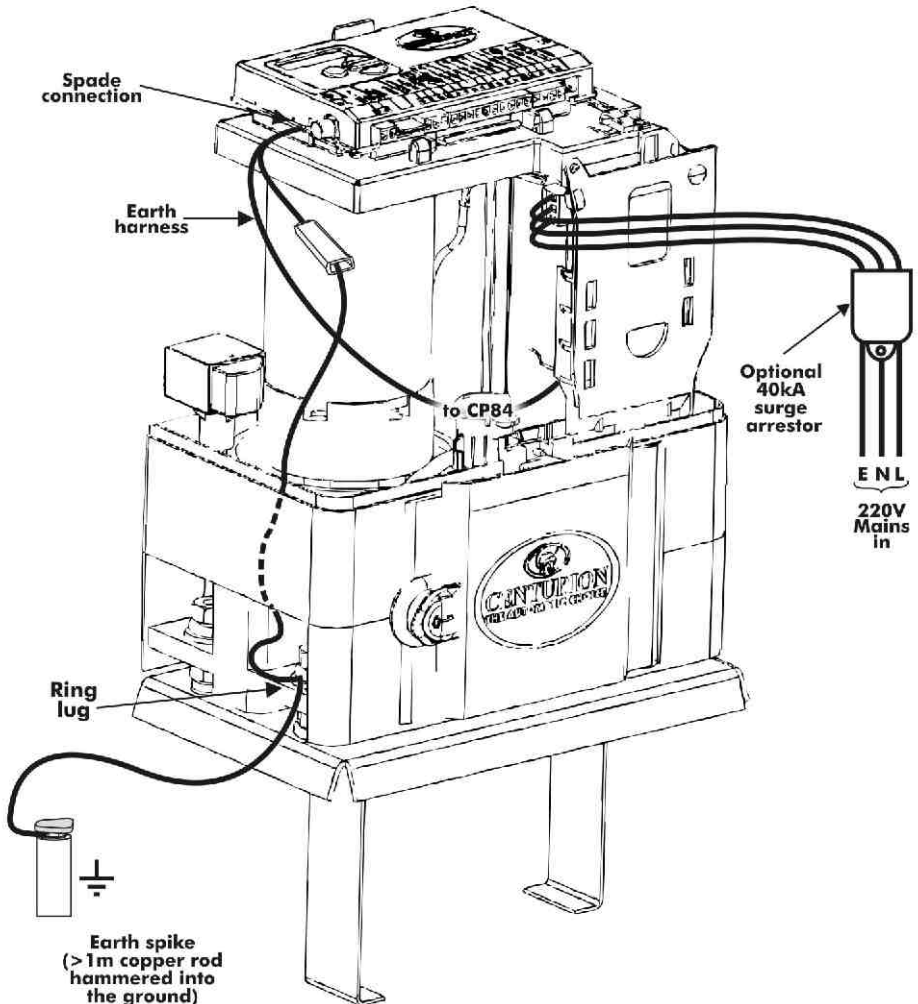

FIGURE 47

18. Commissioning the system

Setting the gate limits

1. Disengage the manual release lever, ensuring that the origin marker is correctly fitted.

Move the gate to the middle of travel and re-engage the manual release lever.

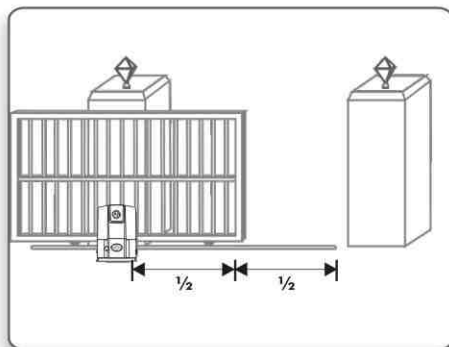



FIGURE 48

2. a) If powering up the system ex-factory, it will request for the operating **Profile*** (operating standard) to be set.
 - ZA: Standard profile for South Africa
 - CE: Standard profile for the European Union
 - UL325: Standard profile for the USAb) Select the **Profile** that will suit the specific region from the list. With this set, the system will automatically proceed to the limit setup menu. Follow the onscreen instructions to complete the setup procedure
- c) If powering up at any stage after this, push and hold the oblong **enter** button () for two seconds.

Select the "limits" menu by pressing the **enter** button (). Follow the onscreen instructions to complete the setup procedure.

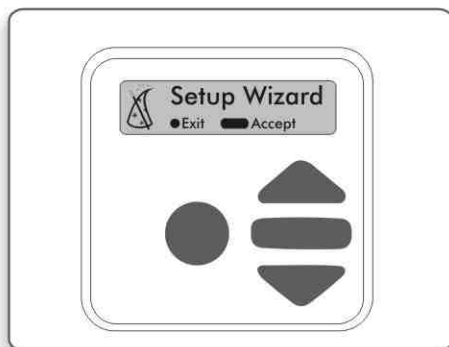

FIGURE 49



*For more details about the **Profile** (operating standard), refer to Section 22, Factory defaults schedule

19. How to set up additional features on the D5 - Evo controller

D5 - Evo controller

Section 20 provides the full menu of features that can be set up on the system. An explanation of each feature is provided in Section 21, Controller features

When setting up the D5 - Evo system via the LCD display, all the steps that have to be followed are clearly provided via the display. It is only necessary to note the following:

- To get into setup mode, press the **enter** () button for two seconds and follow the instructions provided from there
- The buttons provided on the controller for navigating the system are not marked because at each step during the setup, the function given to each button is provided on the display

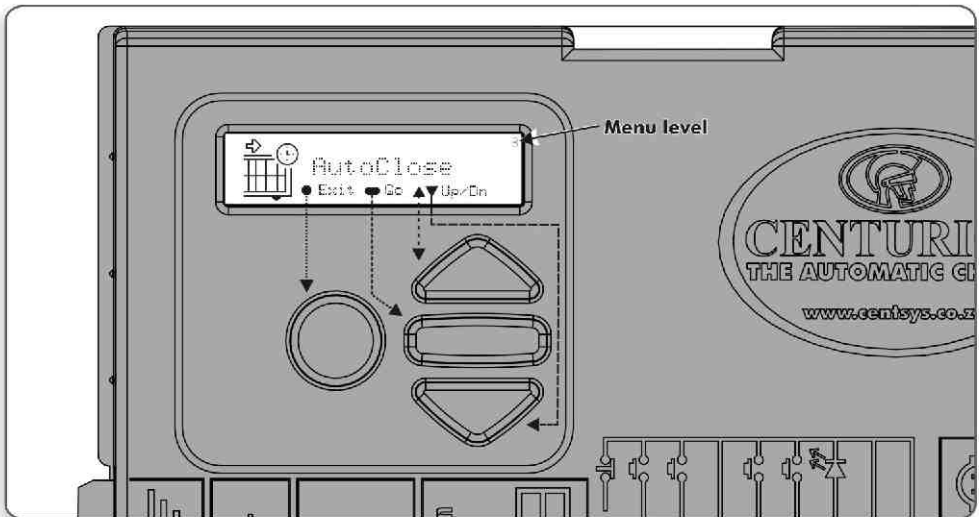



FIGURE 50

- When not in setup mode, i.e. normal mode, the () button is used as a **test** button for operating the system
- The triangular up or down () buttons are used to scroll through the diagnostic screens
- For each feature a factory default setting has been programmed into the controller. Referred to as an operating standard or profile, these defaults have been determined to suit the requirements of the specific region where the installation is being carried out. It is only necessary to change a feature where the default does not suit the installation. When selecting any feature in the menu, details of the current setting stored in the controller are displayed
- Refer to Section 22 for the Schedule of factory defaults for each feature

20. Menu navigation map



1. Setting limits



1.1. Setup wizard



2. Safety

- 2.1. Collision force 2.1.1. Opening collision force
2.1.2. Closing collision force
- 2.2. Collision count
- 2.3. Alarm output
- 2.4. LCK input as ESTOP



3. Autoclose

- 3.1. Autoclose status
- 3.2. Autoclose timer
- 3.3. Autoclose override
- 3.4. Autoclose advanced options 3.4.1. Autoclose fully open
3.4.2. Autoclose partly open
3.4.3. Autoclose partly closed



4. Modes of operation

- 4.1. Operating mode 4.1.1. Standard mode
4.1.2. Condominium mode
4.1.3. Reversing mode
4.1.4. PLC
4.1.5. Deadman Control mode



5. Run profile

- 5.1. Positive close 5.1.1. Positive close mode status
5.1.2. Positive close mode force
- 5.2. Pre-open delay
- 5.3. Pre-close delay
- 5.4. Opening speed
- 5.5. Closing speed
- 5.6. Ramp-up distance
- 5.7. Ramp-down distance
- 5.8. TRG stop distance
- 5.9. IRB stop distance
- 5.10. Crawl distance
- 5.11. Torque limit



6. Infrared beams

- 6.1. PIRAC control.....
 - 6.1.1. PIRAC status
 - 6.1.2. Stop on open.....
 - 6.1.2.1. Stop on open status
 - 6.1.2.2. Stopping distance
- 6.2. IR beam test.....
 - 6.2.1. Status
 - 6.2.2. Test beam
- 6.3. IRBO=IRBC on closing
- 6.4. IR beam alarms.....
 - 6.4.1. Ambush alarm.....
 - 6.4.1.1. Ambush alarm status
 - 6.4.1.2. Broken IRB time
 - 6.4.2. Break-in alarm status
 - 6.4.3. Alarm output



7. Pedestrian

- 7.1. Pedestrian open position
- 7.2. Pedestrian autoclose time
- 7.3. Pedestrian pre-open delay
- 7.4. Pedestrian pre-close delay



8. Courtesy light

- 8.1. Courtesy light timer
- 8.2. Light profile.....
 - 8.2.1. Courtesy light
 - 8.2.2. Pre-flash A
 - 8.2.3. Pre-flash B
 - 8.2.4. Pre-flash C



9. ChronoGuard

- 9.1. Time and date
- 9.2. Time periods.....
 - 9.2.1. Add time period.....
 - 9.2.1.1. Auto function
 - 9.2.1.2. Time-bar function
 - 9.2.2. Delete time period
 - 9.2.3. Edit review time periods
- 9.3. Exclusions.....
 - 9.3.1. Add exclusion.....
 - 9.3.1.1. Auto function
 - 9.3.1.2. Time-bar function
 - 9.3.2. Delete exclusion
 - 9.3.3. Edit review exclusions
- 9.4. Delete all time periods and exclusions



10. General settings

- 10.1. Operating standard
- 10.2. Reset options.....
 - 10.2.1. Factory defaults
 - 10.2.2. Delete all remotes
 - 10.2.3. Delete all time periods and exlusions
 - 10.2.4. Reset all
- 10.3. Diagnostic screen status
- 10.4. Test button disabled status
- 10.5. Backup eeprom
- 10.6. Restore eeprom



11. Remote controls



Press button of valid transmitter *(if menu locked)*

- 11.1. Add remotes
- 11.2. Delete remotes.....
 - 11.2.1. Delete remote by ID
 - 11.2.2. Delete remote button
 - 11.2.3. Delete remote by button
 - 11.2.4. Delete not present
 - 11.2.5. Delete all remotes
- 11.3. Edit remote button
- 11.4. Autolearn
- 11.5. Lock Tx menu
- 11.6. Onboard receiver enable/disable

21. Controller features



Menu 2 - Safety (collision force)

- **Collision force**

If the gate is obstructed, the internal collision circuitry will activate. The response of the system to a collision will vary, depending on the profile (operating standard, e.g. ZA,) selected. Responses can vary from the gate stopping, to the gate reversing. The collision force can be set from minimum to maximum in five discrete steps.

A sixth step will disable collision sensing entirely, allowing maximum force to be achieved. Under this condition, the motor will continue running until it stalls, at which point a collision will be detected.



This level should only be used if additional safety measures are taken. (e.g. infrared beams, sensitive edge, etc.). Collision force can be set independently per direction of travel.

- **Collision count**

A counter monitors the number of collisions that the gate experiences before it reaches the fully closed position. If the value exceeds the value set in the **multiple collision counter** the controller shuts down until the next valid trigger is received. As indication, the **status LED** will flash four times every two seconds. The **multiple collision** fault indication will continue to flash indefinitely or until a valid trigger has been received.

- **Alarm output**

After the preset collision count has been reached, an alarm is activated. The system can be configured to operate one of the following outputs provided on the controller:

- **Onboard buzzer** – emits a continuous tone
- **Pillar / Courtesy light contact** (potential-free normally open contact, fuse protected – 5A)
- **Aux IO** (this is an open collector drive, max current draw 3A, not fuse protected)
- **Safety beam common** (this is an open collector drive, max current draw 3A, not fuse protected)
- **Status LED output** (operate up to three LEDs in parallel or interface with multi-LED driver card, CP78)

- **LCK input as ESTOP**

Allows the Lck (Holiday Lockout) input to be configured as an emergency stop input. When activating the emergency stop it will prevent the gate from moving, and if it is moving, it will immediately stop.



Menu 3 - Autoclose

- **Autoclose status**

When turned on, the **autoclose** feature has the function of automatically closing the gate after a preset autoclose time. The **autoclose** feature is automatically turned on when the controller is set for **condominium** mode of operation.

- **Autoclose time**

The **autoclose** time can be set anywhere from 1 to 255 seconds.

- **Autoclose override**

It is possible for the user to temporarily turn off **autoclose** when the mode of operation is **standard** or **reversing**. To activate **autoclose override**, the Trg input must be activated and maintained for a period longer than the time set for the **autoclose override time**.

The gate response will be to start opening on the Trg trigger, and then to stop as soon as the **autoclose override** feature is activated. On clearing of the Trg input, the gate will continue opening until fully open. The **autoclose** feature is now off and the gate will remain open indefinitely.

The next signal received on Trg will clear the **autoclose override** feature, close the gate, and set the **autoclose** feature back to normal.

- **Autoclose advanced options**

The conditions under which the gate will automatically close can be set within the **Advanced autoclose** options menu:

- **Autoclose on open** - automatically close the gate if it has reached the fully open position
- **Autoclose on partly open** - automatically close the gate if it is stopped while opening, but before reaching the fully opened position
- **Autoclose on partly closed** - automatically close the gate if it is stopped while closing, but before reaching the fully closed position



More than one advanced option can be selected



Menu 4 - Modes of operation

It is possible to select the following modes of operation: **Standard, Condominium, Reversing, PLC** and **Deadman Control Mode (DMC)**. All modes are triggered by closing a normally open contact between the Trg input terminal and the Com terminal.

- **Standard mode**

When stationary, a trigger impulse on Trg will cause the gate to either open or close. On a moving gate, a trigger impulse on Trg will stop the gate. The next impulse on Trg will cause the gate to reverse its direction of travel, i.e. the action is **start-stop-reverse**.

- **Condominium mode**

A trigger impulse on Trg will open the gate under all conditions. If it were closing, it will stop and reverse to open. In this mode of operation, the only way to close the gate is with the **autoclose** feature, which is automatically activated when **Condominium** mode is selected.

- **Reversing mode**

A trigger impulse on Trg will reverse the direction of a moving gate. If it were closing, it will stop and immediately begin opening. If it were opening, it will stop and immediately begin closing.

- **PLC Mode**

- A trigger impulse on FRX (NO) will cause the gate to open. A trigger impulse on the Trg (NO) will cause the gate to close
- A trigger impulse on the Lck/Stop (NC) will cause the gate to stop

- **Deadman Control Mode (DMC)**
 - A permanent trigger on FRX (NO) will cause the gate to open. Removing the trigger will cause the gate to stop
 - A permanent trigger on Trg (NO) will cause the gate to close. Removing the trigger will cause the gate to stop
 - A permanent trigger on Lck/Stp (NC) will stop a moving gate, and prevent a stationary gate from moving



Menu 5 - Run profile

- **Positive close mode (PCM)**
Setting positive close mode to **on** will allow the gate to drive up hard to the closed endstop without causing the collision circuitry to operate. This feature operates only during the last few millimeters of gate travel in closing mode.
- **PCM push force**
The amount of force applied by the motor when in PCM can be set as a percentage of full motor force.
- **Pre-open delay**
Allows a delay between a valid trigger signal being received and the gate commencing movement in the opening direction. A warning light can be set to activate during this delay. (Refer to pre-flash modes of the **pillar light** feature, for more details).
- **Pre-close delay**
Allows a delay between a valid trigger signal being received and the gate commencing movement in the closing direction. The delay will also occur if the gate is set to close automatically. A warning light can be set to activate during this delay. (Refer to pre-flash modes of the **pillar light** feature, for more details).
- **Opening speed**
Sets the maximum opening speed in metres per minute. This can be set from 10 to 22 metres per minute. Selecting maximum will move gate at maximum possible speed.
- **Closing speed**
Sets the maximum closing speed in metres per minute. This can be set from 10 to 22 metres per minute. Selecting maximum will move the gate at maximum possible speed.
- **Ramp-up distance**
Sets the ramp-up distance in centimetres of travel of the gate when starting. This can be set from 10 centimetres to 10 metres in 1 centimetre steps.
- **Ramp-down distance**
Sets the ramp-down distance in centimetres of travel of the gate when stopping. This can be set from 10 centimetres to 10 metres in 1 centimetre steps.
- **TRG stop distance**
Sets the distance over which a moving gate will stop after a Trg input is received. This can be set from 10 centimetres to 1 metre in 1 centimetre steps.
- **IRB stop distance**
Sets the distance over which a moving gate will stop after an **infrared safety beam** is broken. This can be set from 10 centimetres to 1 metre in 1 centimetre steps.

- **Crawl distance**
Sets the final crawl distance in centimetres of travel of the gate when reaching an endpoint. This can be set from 10 centimetres to 10 metres in 1 centimetre steps.
- **Torque limit**
Sets the maximum torque delivered by the motor. The maximum setting is a value of 15, while the minimum is four. This is useful in cases where limited push force is required.



Menu 6 - IR beams

- **PIRAC**
The **Passive-Infrared Autoclose** feature allows the gate to close automatically, as soon as a vehicle or pedestrian has passed through the closing beam. This security feature ensures that the gate stays open for the minimum amount of time possible. If the **autoclose** feature has been enabled, the system will react in the following way:
 - When the gate is triggered to open and nothing moves through or interrupts the closing beam, the gate will open fully and stay open for the period of time determined by the **autoclose** timer
 - However, if the closing beam is interrupted at any stage, while the gate is opening or open, the gate will close immediately after the closing beam is cleared



If the **autoclose** feature has **not** been enabled then the gate will remain open indefinitely. To close the gate the closing beam must be interrupted or the trigger button must be pressed.

- **Stop on open**
If **PIRAC** is enabled, and a vehicle breaks the closing safety beam, the gate will by default, continue to open. If the gate is required to stop at this point, the **stop on open** function must be enabled. The stopping distance setting then determines in centimetres how far the gate will run on after the beam has been broken. The minimum setting is zero, which will cause the gate to stop immediately after the closing beam has been broken. The maximum setting is determined by the length of the gate.
- **PIRAC override**
The **PIRAC** feature can be temporarily disabled in the following manner:
 - With the gate in the closed or partially closed position, press and hold the trigger button. The gate will begin to open and then stop. Continue holding the trigger button until the gate begins to open again
 - Release the trigger button
 - The gate is now in **PIRAC override**
 - To re-enable the **PIRAC** feature press the trigger button briefly
 - The time taken for the gate to come to a stop is equal to the **autoclose override time**, or a minimum of two seconds if the **autoclose override time** is **off**
 - The time taken for the gate to open again after it has come to a stop is approximately three seconds

Example:

- **Autoclose override** time set to five seconds: Total time to temporarily disable the PIRAC feature is approximately eight seconds (5s + 3s = 8 seconds)
- **Autoclose override** time set to **off**: Total time to temporarily disable the PIRAC feature is approximately three seconds

- **IR beam test**

Automatically tests the safety beams before each gate cycle. (e.g. as required by CE.) In order for this feature to work, the power supply negative of beam transmitter must be wired to the safe common terminal of the controller.

- **IRBO=IRBC**

Configures the opening beam to act as a closing beam while the gates are closing.

- **IR beam alarms**

While the gate is fully closed, this feature allows the following alarms:

- **Ambush alarm**

Activates an alarm if either the opening or closing beams have been continuously interrupted for a predefined time. The alarm will remain activated while the beams are interrupted.

For example, if a would-be intruder covers the beams so that when the gate is opened, the gate will stay open, the system will detect this beam override taking place and set off an alarm.

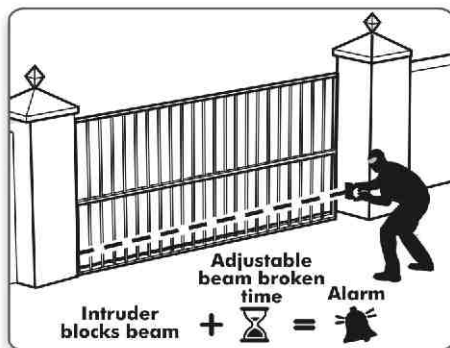

FIGURE 51

- **IR beam broken time**

The time that the beams must be interrupted before the alarm is activated.

- **Break-in alarm**

Activates an alarm if the closing beam on the outside of the property is interrupted. The alarm remains activated while the beam is broken, and for a period of 30 seconds thereafter. This time is fixed.



If this alarm is used, it is recommended that **TWO parallel closing beams** are used to reduce the chance of false triggering.

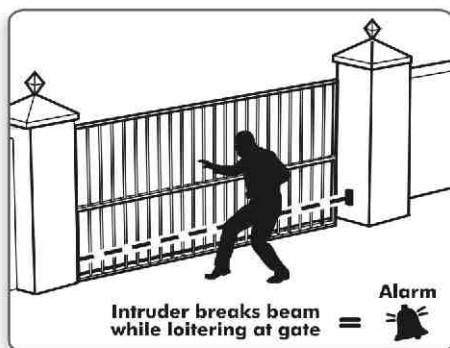

FIGURE 52

- **Alarm output**

The system can be configured to operate one of the following outputs provided on the controller:

- **Onboard buzzer** – emits a continuous tone
- **Pillar / Courtesy light contact** (potential-free normally open contact, fuse protected – 5A)
- **Aux IO** (this is an open collector drive, max current draw 3A, not fuse protected)
- **Safety beam common** (this is an open collector drive, max current draw 3A, not fuse protected)
- **Status LED output** (operate up to three LEDs in parallel or interface with multi-LED driver card, CP78)



Menu 7 - Pedestrian opening

This feature is associated with the Ped input on the controller. When activating this input, the system will open the gate to the pedestrian open position, and then automatically close after the pedestrian autoclose time lapses. If the Ped connection to Com is maintained, then the gate will remain open, and when the connection is broken, it will close after the pedestrian autoclose time has expired.

The time taken for the gate to open to pedestrian is dependent on the pedestrian pre-open delay and the time required for the gate to close from the pedestrian position is dependent on the pedestrian pre-close delay.

- **Pedestrian open position**

Sets the maximum opening of the pedestrian gate in metres, in one centimetre steps.

- **Pedestrian autoclose time**

Sets the autoclose time in seconds after a pedestrian opening. This time can be set from zero seconds to four minutes in one second steps.

- **Pedestrian pre-open delay**

Sets the time delay between the pedestrian input being activated, and the gate actually opening. This enhances safety in cases where the pedestrian has to reach through the gate in order to activate the pedestrian input. A warning light* would typically be active during this delay. This delay can be set from zero seconds to four minutes in one second steps.

- **Pedestrian pre-close delay**

Sets the time delay between the pedestrian autoclose timer expiring, and the gate actually closing. A warning light* would typically be active during this delay. This delay can be set from zero seconds to four minutes in one second steps.



*The warning light is any light wired to the courtesy (pillar) light contacts, as described in Menu 8, which follows.



Menu 8 - Courtesy (pillar) light

This feature is associated with the **light** connections on the controller. Refer to Section 16 of the manual for details on how to connect a pillar or security light to the controller.

The pillar light circuit has multiple functions:

- It operates as a courtesy light and switches on for a selectable time period every time the gate is activated
- The courtesy light can also be turned on for the same time period by momentarily connecting the Aux terminal to the Com terminal via a pushbutton
- The courtesy light can also be turned on permanently by connecting the Aux terminal to the Com terminal via a pushbutton, for three seconds. A short pulse thereafter will switch the lights off. The status LED will flash once every two seconds to indicate that the courtesy light is on permanently. The abovementioned facility can also be achieved via a remote learned to the system and mapped to the courtesy light function from within the remotes menu



The gate will not open when using the **Aux** trigger input.

- When the Ped input is triggered, the courtesy light flashes for an adjustable (1 to 255 seconds) pre-flash time, before the pedestrian gate opens
- The courtesy light can also be controlled via the **Auto activation** function, or the light time-bar function as described in the Chronoguard (Time periods) menu - Menu 9

- **Courtesy light time**

The time that the courtesy light will remain activated can be set from four seconds to ten hours in one second increments.

- **Light profile**

- The courtesy light can be selected to operate according to one of the following:

- **Courtesy light** as explained earlier

- **Pre-flashing mode**

- If pre-flashing Mode A, B or C is selected, the behaviour of the courtesy light will be as follows:

- **Mode A** will turn on the courtesy light only while the gate is moving

- **Mode B** will flash the courtesy light during the pre-opening and pre-closing delays, as well as while the gate is moving

- **Mode C** will turn on the courtesy light during the pre-opening and pre-closing delays, as well as while the gate is moving

In these pre-flashing modes, the timed courtesy light functionality is not available



Menu 9 - ChronoGuard (Time periods)

- **ChronoGuard™** (patent pending) is a powerful feature which has been added to the new generation CENTURION controllers. An integral **Real Time Clock (RTC)** is used to provide time-based functionality, including the automatic activation or time-barring of specific controller inputs, and the time-barring of specified remote control buttons used together with the onboard NOVA rolling code (Keeloq™ encryption) receiver.

- The RTC will keep time for a minimum of one hour without any power

- **Time Periods**

A time period is defined by a start and end date and time. Up to 100 time periods can be defined. A time period can be a once off event, or can be set to repeat on a weekly or annual basis. The weekly repeat can be chosen to occur on every day of the week, weekdays only, weekends only, or any specific day. The minimum duration of a time period is one minute. **Once off** time periods have the highest precedence, followed by **annual** and then **weekly**. When appropriate, a "Tp" icon will appear on the display to indicate that a **time period** is active.

- **Autoactivations (Auto function)**

The following controller **inputs** can be set to activate automatically during a time period:

- Free-exit (FRX)
- Pedestrian opening (Ped)
- Holiday Lockout (Lck)
- Closing beam (IRBC)
- Courtesy light control (Aux)

During the relevant time period, the selected input will be activated. Where appropriate, the diagnostic LED of the relevant input will illuminate.

The following controller **output** can be set to activate automatically during a time period:

- Auxiliary output (Aux IO)

- **Time-barring**

Time-barring of **inputs** is divided into physical inputs and RF inputs (inputs mapped to a NOVA rolling code (Keeloq™ encryption) transmitter button).

The following **physical inputs** can be **time-barred** (prevented from operating) during a time period:

- Trigger (Trg)
- Pedestrian opening (Ped)
- Free-exit (FRX)
- Holiday Lock (Lck)
- Courtesy light control (Aux)

The following physical **outputs** can be **time-barred** (prevented from operating) during a time period:

- Courtesy (pillar) light relay (Light)
- Auxiliary output (Aux IO)

The following **RF inputs** can be **time-barred** (prevented from operating) during a time period:

- Trigger (Trg)
- Pedestrian opening (Ped)
- Free-exit (FRX)
- Holiday Lock (Lck)
- Courtesy light control (Aux)



Time-barring of a NOVA rolling code (Keeloq™ encryption) transmitter is specified at the time of coding the transmitter into the system. Once an RF input is defined as time-barred, any **time-barred** transmitter associated with that input will be time-barred during the relevant **time period**.

If a physical or RF input is currently **time-barred**, any attempt to activate it will be acknowledged by a short beep of the onboard buzzer. The input, however, will not activate.

- **Exclusions**

Exclusions are used to prevent scheduled time periods from occurring at specific times (eg: public holidays). While **time-barring** can be used to achieve a similar end, exclusions can also be used to exclude **time-barring** itself. Each exclusion consumes one time period. Exclusions have the highest precedence, followed by **time-barring** and then **autoactivations** (auto function).



Menu 10 - General features

- **Operating standard**

Regional operating standards can be set. Applying this setting will automatically configure the controller settings to conform to the specific regions standard (e.g. UL325 or CE)

- **Reset options**

The controller settings can be reset through the **reset options** menu. Various reset options are available:

- **Factory defaults** – All settings will be restored to the default values dictated by the operating standard/profile that is currently selected. All remote controls and gate limits will not be affected.
- **Delete all remotes** - Delete all the remotes stored in the system, no settings affected
- **Delete all time periods** - All auto
- activation (auto function) and time-bar functions are deleted or removed
- **Reset all** – Clears and defaults the system completely. Unit will be reset to the factory default settings in addition to clearing all remotes and time periods

- **Diagnostic screen**

Allows a diagnostic screen to be displayed. This can be useful when troubleshooting, but requires some technical knowledge.

- **Round test button**

Allows the round test button on the controller to be disabled, in cases where higher security is required.

- **Backup EEPROM**

Allows all controller settings, remote controls and time period functions to be backed up. Requires a backup module, obtainable from CENTURION.

- **Restore EEPROM**

Allows all controller settings, remote controls and time period functions that have previously been backed up, to be restored. Requires a backup module, obtainable from CENTURION.



If the backup module is used to restore the settings of a different D10 operator, then the gate limits setup procedure must be performed again.



Menu 11 - Remote controls

The controller is capable of learning up to 125 CENTURION NOVA rolling code (Keeloq™ encryption) remote controls buttons. Each transmitter can have up to four buttons.

- It is possible to artificially increase the number of buttons of a multi-button transmitter by using a two button combination
- One of the buttons is used as a **shift button** to allow the other buttons to be used again in combination with this button. In other words the user will press and hold the shift button, before pressing one of the other buttons to create a **new** button
- The shift button cannot be used as a button on its own, it must always be used in combination with the other buttons



Benefits of the shift button system:

- Use of the **shift button system** allows a three button transmitter to gain an extra button and operate four functions and likewise a four button transmitter gains two extra buttons and can operate six functions
- Another benefit of using the shift button system is that **it requires both hands to operate the two button combination**. This prevents the user from accidentally enabling sensitive functions such as holiday lockout on the controller



Each transmitter learned into the system is assigned a unique transmitter ID.

• Press valid button

If the **remote controls menu** has been locked as discussed later, only by pressing a button of a transmitter learned into the system, can the **remote controls menu** be accessed.

• Add remote

Any button can be set to control the trigger, pedestrian, free-exit, holiday lockout or courtesy light control (Aux) inputs. When adding transmitters, it is recommended that a record be kept of the ID number allocated by the system to each respective transmitter and the person to whom the transmitter is given. This is necessary should selective deletion be required at a later stage.

• Delete remote

Transmitters can be deleted at any stage according to one of the following methods:

• Delete remote by ID

Each transmitter can be deleted individually according to its unique ID. To facilitate this, a record of the ID and the person to whom the ID has been assigned must have been made at the time of learning the transmitter into the system. The transmitter is not required for this operation.

- **Delete remote button**
The operation of a button of a particular transmitter can be cleared. For example, it allows the **holiday lockout** function set on one remote button of a transmitter to be cleared, without affecting the other operations that the same transmitter performs. The transmitter is required for this operation.
- **Delete remote by button**
Use this procedure to remove the transmitter from the system. All button functionality will be removed. The transmitter is required for this operation.
- **Delete not present**
Allows for transmitters that have not been used within a selectable time period to be removed from the system. The time period can be set from one hour to seven days, in one hour increments.
- **Delete all remotes**
Clears the entire memory. All transmitters will be removed.
- **Edit remote button**
Change the function of one button to perform another function. For example, button one's function is to open the gate completely. To change this, use the **edit remote button**, select Ped, and button one of the same remote will now only open the gate to pedestrian.
- **Autolearn**
Allows a selectable time period to be set, during which any specific button, when pressed, will be learned to a specific function. The function itself will also be activated when the button is pressed. After the time period has expired autolearn is disabled, and no further buttons will be learned. The time period can be set from one hour to seven days in one hour increments.
- **Tx menu locked**
Allows the **remote controls menu** to be locked, preventing the unauthorized addition of new transmitters to the system. Once enabled, the **remote controls menu** can only be accessed by pressing a valid transmitter button.
- **Onboard receiver**
The onboard NOVA rolling code (Keeloq™ encryption) receiver can be disabled in the unlikely event that it causes interference with an existing external receiver.

22. Factory defaults schedule

South African standard profile - ZA

Parameter Description	Unit	Minimum	Default	Maximum
Menu 1 - not applicable				
Menu 2				
Opening collision force	Level	1	3	Max
Closing collision force	Level	1	3	Max
Collision count	Collisions	1	4	255
Alarm output	B, CL, SC, XIO, LED		B	
LCK as ESTOP	Yes or No		No	
Menu 3				
Autoclose status	On/Off		Off	
Autoclose timer	mm:ss	00m:00s	00m:15s	04m:00s
Autoclose override time	mm:ss	00m:00s	00m:03s	04m:00s
Autoclose from fully open	On/Off		On	
Autoclose from partly open	On/Off		On	
Autoclose from partly closed	On/Off		Off	
Menu 4				
Modes of operation	S, C, R, P, D		S	
Menu 5				
PCM status	On/Off		Off	
PCM force	%	10%	30%	100%
Pre-open delay time	mm:ss	00m:00s	00m:00s	01m:05s
Pre-close delay time	mm:ss	00m:00s	00m:00s	01m:05s
Opening speed	m/min	10m/min	Max	Max
Closing speed	m/min	10m/min	Max	Max
Ramp-up distance	m	0.1m	0.2m	10m
Ramp-down distance	m	0.1m	0.2m	10m
TRG stop distance	m	0.1m	0.25m	1m
IRB stop distance	m	0.1m	0.17m	1m
Crawl distance	m	0.01m	0.03m	1m
Torque limit	A	4A	15A	15A
Menu 6				
PIRAC control	On/Off		Off	
Stop on open	On/Off		Off	
Stopping distance	m	0m	0.1m	9.99m
IR beam test	On/Off		Off	
Test beam	IRBC/IRBO/both		IRBC	
IRBO=IRBC	On/Off		Off	



Parameter Description	Unit	Minimum	Default	Maximum
Menu 6 (continued)				
Ambush alarm	On/Off		Off	
Ambush time	hh:mm	00h:01m	00h:01m	04h:00m
Break-in alarm	On/Off		Off	
Alarm output	B, CL, SC, XIO, LED		B	
Menu 7				
PED opening	m	0.05m	1m	see note*
PED autoclose	mm:ss	00m:00s	00m:05s	04m:25s
PED pre-open delay	mm:ss	00m:00s	00m:02s	04m:00s
PED pre-close delay	mm:ss	00m:00s	00m:00s	04m:00s
Menu 8				
Light timer	h:mm:ss	0h:00m:04s	0h:02m:00s	9h:59m:59s
Light profile	CL, PFA, PFB, PFC		CL	
Menu 9 - not applicable				
Menu 10				
Diagnostic screen	On/Off		Off	
Round test button	On/Off		On	
Menu 11				
Delete not present	On/Off		Off	
Autolearn	On/Off		Off	
Tx Menu lock	On/Off		Off	
Onboard receiver	On/Off		On	

*Limited by gate length

Legend

B	Onboard buzzer	PFA	Pre-flashing mode A
C	Condominium mode	PFB	Pre-flashing mode B
CL	Courtesy light	PFC	Pre-flashing mode C
D	Deadman Control Mode	R	Reversing Mode
IRBC	Closing safety beams	S	Standard Mode
IRBO	Opening safety beams	SC	Safety common
LED	Status LED	Tx	Transmitter
P	PLC mode	XIO	Auxiliary input/output

23. Description of terminal functions

12V +	Positive battery connection.  Battery terminal normally indicated as + or red (right hand battery)
12V -	Negative battery connection.  Battery terminal normally indicated as - or black (left hand battery)
Motor	Motor output – connects to the thick blue motor wire
Motor	Motor output – connects to the thick black motor wire
Aux IO	The Aux IO terminal provides an open collector output which can be used for alarm or auto function purposes. If the collision alarm output or the IRB alarm output has been configured to Aux IO , then the negative of the alarm device must be connected to this terminal. The positive of the alarm device must be connected to the Aux 12V Out terminal. Similarly, if Aux IO is autoactivated via a ChronoGuard auto function time period, the device being switched (typically a 12V relay) must be powered from the Aux 12V Out terminal, and have its negative switched by Aux IO . If the Aux IO has not been selected as either an alarm indicator output or autoactivated output, the Aux IO terminal will behave as a Com termination point. All trigger signals, etc., have their return path to one of the Com terminals.
Com	The common termination point. All trigger signals, etc. have their return path to one of the Com terminals.
Status	External gate status indicator. (A low current output signal.) An output terminal which provides a low current, drive (approx. 4,5V DC, 20mA) to a LED which can be used to indicate the gate status remotely. If more than three LEDs are required it is necessary to fit the CP78 multi-LED driver card. For more details on the feedback about the status of the gate provided by the status LED refer to Section 24.
Aux	Activates the pillar light relay. (A normally-open potential-free input). Momentarily connecting this input to Com will cause the light relay to energize for a period of time as set in the courtesy light timer menu. If the connection is made for a period exceeding three seconds the pillar light relay will latch and remain latched indefinitely until a new momentary connection to Com is given.
FRX	Free-exit input. (A normally-open potential-free input). Momentarily connecting this input to Com will cause a gate which is closed, or closing, to open or re-open. If the gate is open, or opening, the signal has no effect other than to reset the autoclose timer (if selected). Free-exit (FRX) never initiates a closing cycle. The only way to close a gate, if only the FRX input is used, is to activate the autoclose feature on the controller.
Com	The common termination point. All trigger signals, etc. have their return path to one of the Com terminals.

Ped **Pedestrian opening input.** (A normally-open potential-free input). Momentarily connecting this input to Com will cause the gate to open to the pedestrian open position. For more information refer to the pedestrian feature in Section 21.

Trg **Trigger input.** (A normally-open potential-free input.) Momentarily connecting this input to Com will cause the gate to open, close or stop, depending on the operating mode selected. For more information see the autoclose feature and modes of operation.

Lck/Stp **Holiday Lockout or gate stop input.** (A normally-closed potential-free input). For as long as a connection between this input and Com is maintained the controller will behave normally, but when this connection to Com is broken all inputs are inhibited.



- If this input is enabled while the gate is moving or in the open position, it will only activate and inhibit operation of all the inputs when the gate is back in the closed position
- This input can be configured as an emergency stop input. Refer to Section 21, Menu 2 for details



If the Lck function is not required a link must be fitted between Lck and Com*(refer to note on page 55)

Safety Open **Opening beam safety input.** (A normally-closed potential-free input). As long as a connection between this input and Safe Common is maintained the controller will behave normally. When this connection is broken it will prevent the gate from opening if it is stationary, and will stop and close the gate if it is opening. This input has no effect if the gate is closing.



If the Safety Open and reverse functions are not required a link must be fitted between Safety Open and Safe Common for the controller to operate normally* (refer to note on page 55)

Safety Close **Closing beam safety input.** (A normally-closed potential-free input). As long as a connection between this input and Safe Common is maintained the controller will behave normally. When this connection is broken it will prevent the gate from closing if it is stationary, and will stop and open the gate if it is closing. This input has no effect if the gate is opening.



If the Safety Close function is not required a link must be fitted between Safety Close and Safe Common for the controller to operate normally* (refer to note on page 55)

Aux 12V Out **Auxiliary power connection.** Provides +12V DC supply for auxiliary equipment such as a radio receiver, photo cells, etc. It is electronically limited to 300mA.

Safe Common **Used for switching the power supply to the safety beams.** If automatic beam testing is required, the negative power supply connection of the beam transmitter only must be wired to this point. In addition, the beam test circuit must be switched on via Menu 6. See Section 21.

Light/light **Pillar light connection.** These two terminals provide a normally open potential-free contact which is generally used to switch on a pillar light (courtesy light). This contact is fuse protected – refer to Section 3 for fuse specifications.



- * When setting up the controller for the first time or after a full reset back to factory default has been performed, the system will electronically override the Safety Inputs and allow the system to function without the links.

However, if safeties are connected to either or both inputs thereafter, there must be a normally closed circuit maintained for the system to operate correctly.

i.e. if beams are fitted and then removed, the circuit which is affected must be replaced with a wire link to create the normally closed circuit.

24. Diagnostics

Diagnostic LEDs

The D5 - Evo controller has a series of diagnostic LEDs which indicate the state of the inputs.

Normally open inputs are indicated by a **red** LED, and normally closed inputs by a **green** LED. An illuminated **red** LED indicates that the signal is present (e.g. intercom button pressed), while a non-illuminated **green** LED indicates that the signal is absent (e.g. IRB broken).

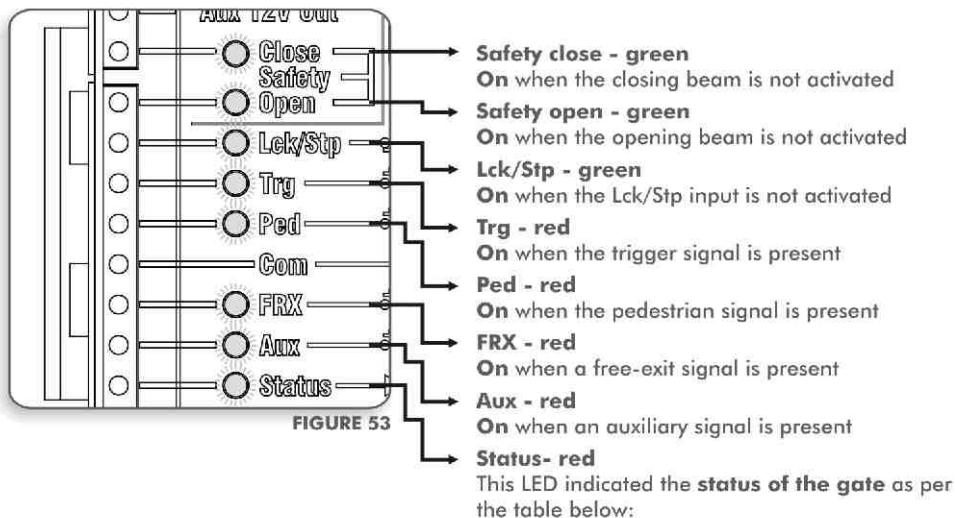

Gate status LED

Off	Gate is closed
On	Gate is partially or fully open
Continuous slow flash	Gate is opening
Continuous fast flash	Gate is closing
One flash every two seconds	Pillar light override is activated
Two flashes every two seconds	No mains present
Three flashes every two seconds	Battery voltage is low
Four flashes every two seconds	Multiple collisions have occurred

LCD display

The LCD display shows useful information regarding the status of the system.

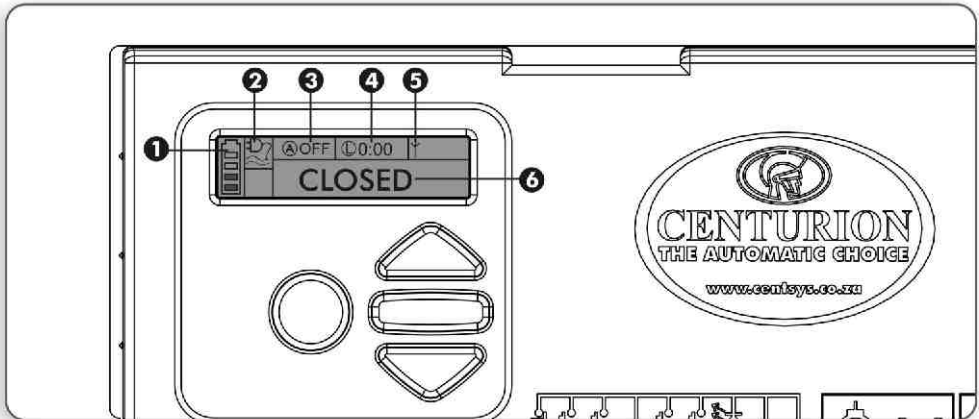

FIGURE 54

1. Battery icon

Indicates the state of charge of the battery.

- Four solid bars = full capacity
- Two solid bars = 50% capacity
- No solid bars, with the icon flashing = battery empty

2. Mains icon

Displays the presence/absence of mains voltage:

- Plug solid = mains present and battery charging
- Plug hollow and flashing = No mains present and battery not charging

3. Autoclose information

- Displays the state of the autoclose function
- Displays off if autoclose is not selected
- OVR if autoclose is overridden, and the remaining autoclose time if autoclose is active
- POVR indicates that the PIRAC option is overridden

4. Pillar light information

- Displays the remaining light time if courtesy light mode is selected
- Pre-flashing mode is displayed if pre-flash is selected
- LIT will be indicated if the pillar light has been turned on permanently

5. Onboard receiver information

Displays the current input being activated by the onboard receiver.

6. Status information

Displays useful information regarding the status of the gate.

Buzzer feedback

A warning buzzer will sound (where applicable) as per the table below:

Inhibitor name	Priority	Number of beeps	Fault type	Gate continues to operate	User can correct error
Break-in alarm	1	Continuous tone for 30 seconds	Alarm	N/A	N/A
Ambush alarm	2	Continuous tone until IRBs are cleared	Alarm	N/A	N/A
Battery low	4	3 beeps periodically for 30 seconds	Power system fault	Yes*	Yes
Multiple collision	3	Periodic until condition is cleared by user (500/500ms)	Collision	No	Yes
Auxiliary overload	5	5 beeps periodically for 30 seconds	Hardware	No	No
Holiday Lockout	6	1 beep periodically for 30 seconds	User	No	Yes
Emergency stop	7	1 beep periodically for 30 seconds	User	No	Yes
Time-barring	8	1 beep periodically for 5 seconds	User	No	Yes
No limits set	9	3 short beeps for 5 seconds	Lost	No	Yes
Mains failure	10	2 beeps periodically for 30 seconds	Power system fault	Yes	Yes
Beams broken (any)	11	1 beep periodically for 30 seconds	User	No	Yes
Beams failure	12	5 beeps periodically for 30 seconds	Hardware	No	No
DOSS disconnected	13	5 beeps periodically for 30 seconds	Hardware	No	No
Fuse blown	14	5 beeps periodically for 30 seconds	Hardware	No	Yes
Motor disconnected	15	5 beeps periodically for 30 seconds	Hardware	No	Yes
Bridge damaged	16	5 beeps periodically for 30 seconds	Hardware	No	No
Gate stalled	17	4 beeps periodically for 10 seconds	Collision	No	Yes
No magnet detected	18	Periodic while gate runs (500/500ms)	Lost	Yes	Yes

* Gate will close fully and then shutdown for two minutes

25. Fault-finders guide

Problem

Possible faults

Gate does not move



- Fuse is blown – Check 30A ATO fuse, and replace if necessary
- Lck (Holiday lockout) input activated. Green Lck light should be **on**
- IRBC/IRBO (IR beams) inputs activated
- IRBC - gate will not close once open; IRBO - gate will not open once closed
- Green IRBC/IRBO lights should be **on** - check cabling and Aux 12V Out
- Latching input on Trg or FRX



Both Trg and FRX lights must be off for gate to operate.

- Check for an autoactivation (auto function) on FRX and Trg inputs. Refer to diagnostic screen with matrix showing different autoactivations (auto function) and time-barring functions on the different inputs
- Check the battery condition with procedure A: Low battery voltage condition, later in this section
- If status light flashes four times or there is a “Max Collisions” indication on the LCD display, then the operator is in Multiple Collision Mode. If required, check with procedure B: False collision detection, later in this section

Gate moves a short distance, and then stops

- Check the battery condition with procedure A: Low battery voltage condition, especially if the status light flashes three times or there is a “Battery Low” indication on the LCD display
- Check for false collisions with procedure B: False collision detection, later in this section (status light could also flash four times if the number of detected collisions exceeded the Collision counter feature value) and LCD indicates “Max Collisions”
- Intermittent IRBC/IRBO signals. Check that the voltage applied to the beams is appropriate
- Spurious trigger. Intermittent short due to possible moisture on the FRX or Trg inputs. Monitor FRX or Trg LED's
- If the problem is still not solved, the main controller might be faulty

Gate starts closing, then stops and re-opens

- Check collision sensitivity and other causes with procedure B: False collision detection

Problem

Possible faults

Gate repeatedly overrides its end-of-travel limits	<ul style="list-style-type: none">• Besides a faulty controller, which will be considered last, the only components that could cause this symptom are a missing origin, or and most unlikely, a faulty DOSS sensor• However, initially before the gate overrides its limits, if the origin is not detected, the controller will automatically start beeping when the gate is running, but it will allow normal operation <p>Check for the following:</p> <ul style="list-style-type: none">• Check that the origin marker is correctly positioned as shown on pages 26 to 27• Check if the gate origin has accidentally moved. If so, reset the limits as directed on page 35• Check that the DOSS sensor harness is properly plugged into the magnetic origin switch, the DOSS sensor and the controller• Carefully check the condition of the harness - look out for any bad crimp joints between the wires and the connectors on the harness• Check that the magnetic origin switch is mechanically switching. While in manual mode, slide the gate backwards and forwards so that the magnet passes the switch each time. Listen out for a distinctive click as the switch operates. Also confirm the direction of the magnet using the relevant diagnostic screen (e.g. magnet on the left or magnet on the right)• Check that the magnetic origin switch is securely clipped into the housing• Unclip and lift out the DOSS sensor and check that there is no evidence of oil on the sensor eyes or ant/dirt ingress• If the problem is not solved, the main controller might be faulty
Unreliable autoclose	<ul style="list-style-type: none">• Latching receiver on Trg would activate the autoclose override feature• Long pulse on Trg would activate the autoclose override feature.• Faulty IRBC Beam signal• Intermittent power loss, check for low voltages with procedure A: Low battery voltage condition• If the problem is still not solved, the main controller might be faulty
Gate opens to pedestrian and closes	<ul style="list-style-type: none">• Intermittent fault on Ped (Pedestrian) input. Check wiring, and keyswitch/keypad operation• Check Procedure B: False collision detection• If the problem is still not solved, the main controller might be faulty
Gate takes a few seconds before it opens to pedestrian	<ul style="list-style-type: none">• By default the motor would delay opening to pedestrian for two seconds. This time can be changed by altering the value of the Pedestrian pre-open delay feature - refer to Section 21, Menu 7.3

Problem

Possible faults

Gate opens to pedestrian and stays open

- There is a continuous Ped signal, the Ped light will be on continuously. (The Ped light and signal must turn on momentarily for the gate to close after a pedestrian signal)
- The Pedestrian feature operated via the onboard receiver could have been inadvertently set to be latching. Refer to the remotes diagnostic screen for assistance
- If an external receiver is operating the Pedestrian input, check for an accidental latching contact, or a faulty keyswitch/keypad
- If the problem is still not solved, the main controller might be faulty

Gate opens from the intercom, but not via remote control

- The fault is with the receiver
 - Internal receiver could be locked
 - Check remotes are correctly learned to the receiver. Refer to remotes diagnostic screen for verification
- The onboard receiver could be faulty
- If an external receiver is used, check:
 - the wiring between the receiver and control card
 - that the receiver has power
 - that the receiver is not faulty
 - that the remotes are learned correctly to receiver

Procedure A - Low battery voltage condition

Status light flashes three times – LCD indicates "Battery Low"

If the battery voltage is less than 13.5V, the motor would not operate at all. For any other voltage, the battery could still be the cause of the problem. Is the battery being properly charged?

- Check the "mains present" icon on the main diagnostic screen or switch to the battery charger diagnostic screen and check the charger voltage – right hand value. This should indicate xV
- Check that the mains power is turned on (measure 220V AC on the mains connector)
- Check that the red LED on the side of the charger is lit
- Check the charger's supply fuse (D5 - Evo charger – 3A)
- Check that the white battery charger connector is making proper contact
- Check the condition of the battery leads, terminals and connectors. Look for and correct all loose connections and signs of corrosion
- The battery might be discharged. Measure the battery voltage with the charger connected, if the voltage is below 13.5V then the battery is discharged. The number of opening cycles per hour may be excessive, thus discharging the battery. Refer to the Trip Counter diagnostic screen for assistance. Charge the battery if required
- Charger might be faulty. Disconnect the battery, and measure the voltage on the battery leads. It must be between 13.6V and 13.8V, if not replace the charger
- Battery might be old, and might have to be replaced. If in doubt test as follows:
 - Check that the battery is charged, by ensuring that the battery voltage is above 13.5V with the charger connected. (If the battery is in a good condition it would probably pass the test without being fully charged)

- Disconnect the charger from the battery
- Remove the DC Motor leads from the DC Controller
- Apply the DC motor leads directly to the battery, while measuring the battery voltage



First make sure that the moving gate will not pose any danger

- If the battery voltage drops to below 13.5V then the battery must be replaced



Before replacing the battery, measure the charging voltage on the battery leads with the battery disconnected. Voltage must be between 13.6V and 13.8V. If not, replace the charger

Procedure B - False collision detection

Status light flashes four times to indicate that number of collisions have exceeded the Collision Counter feature value. LCD screen indicates "Max Collisions"

With the operator in manual mode, check the following and correct if necessary:

- Badly running gate, or something physically obstructing the gate. Check along the entire travel of the gate
- Rack is not pressing down on to pinion
- Bad rack joints
- Wheels are not seized or running badly
- Top guide rollers are not restricting the gate
- No dirt on rail
- No physical damage to the rail
- Wheel catching side of pinion

With the operator in normal mode, check the following and correct if necessary:

- Gate is not hitting the endstop

Do a general inspection of system, check the following and correct if necessary:

- No ants, dirt, oil or water in and around the DOSS sensor
- DC motor wires for loose connections
- DOSS sensor wire harness is securely plugged into controller
- DOSS sensor is securely clipped into the housing
- If the problem is not solved replace the DOSS sensor and main controller



Red/black/orange wire = Origin switch, and
Red/black/purple wire = DOSS sensor

26. Manual operation

Disengage gearbox/drive

1. Use key to open access door to manual override.



Do not remove the thumbwheel. Removal of the thumbwheel may result in water entering the gearbox and the warranty will be void.

2. Rotate thumbwheel clockwise until gearbox releases and gate can be moved manually.
3. If the gearbox must be left in manual mode for an extended period of time for whatever reason, it is recommended that the access door is locked. This secures the cover and prevents access to the inside of the unit, which contains high voltages. It also prevents theft of any components and provides full protection from the elements.

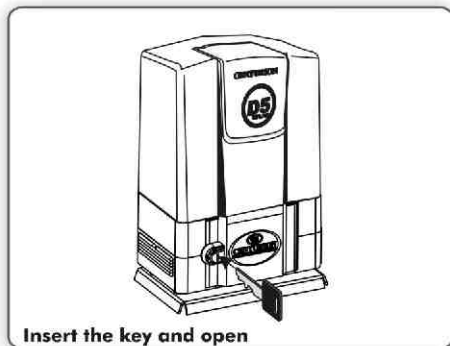

Insert the key and open

FIGURE 55

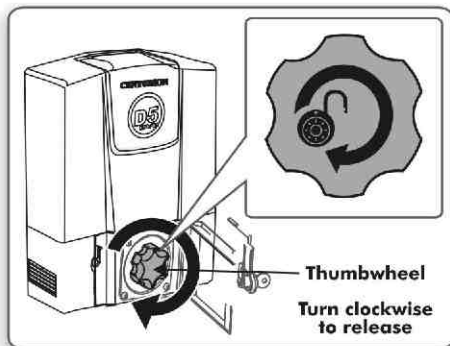

FIGURE 56

Re-engage gearbox/drive

1. Rotate thumbwheel anti-clockwise until thumbwheel feels loose in the hand. Make sure that the manual override access door can be closed.
2. Slide gate until gearbox/drive engages.



Do not remove the thumbwheel. Removal of the thumbwheel may result in water entering the gearbox and the warranty will be void.

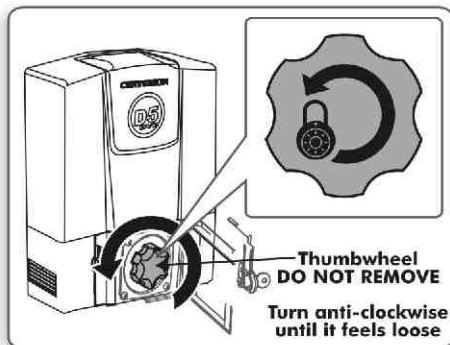

FIGURE 57

27. Installation handover

Once the installation has been successfully completed and tested, it is important for the installer to explain the operation and safety requirements of the system.

NEVER ASSUME THE USER KNOWS HOW TO SAFELY OPERATE AN AUTOMATED GATE!

Even if the user has used one before, it does not mean he knows how to SAFELY operate it. Make sure that the user fully understands the following safety requirements before finally handing over the site.

The following needs to be understood by the user:

- How to operate the manual release mechanism. **(Show them how by demonstration)**
- How the obstruction detection and all other safety features work. **(Show them how by demonstration)**
- All the features and benefits of the operator, i.e. Safety beams, Chronoguard, etc.
- **All the safety considerations associated with operating an automated gate. The user should be able to pass this knowledge on to all other users of the automated system and must be made aware of this responsibility.**



- **Do not activate the gate operator unless you can see it and can determine that its area of travel is clear of people, pets, or other obstructions**
- **NO ONE MAY CROSS THE PATH OF A MOVING GATE.** Always keep people and objects away from the gate and its area of travel
- **NEVER LET CHILDREN OPERATE OR PLAY WITH THE GATE CONTROLS, and do not allow children or pets near the gate area**
- **Be careful with moving parts and avoid close proximity to areas where fingers or hands could be pinched**
- **Secure all easily accessed gate operator controls in order to prevent unauthorized use of the gate**
- **Keep the automated gate system properly maintained, and ensure that all working areas are free of debris and other objects that could affect the gate operation and safety**
- **On a monthly basis, check the obstruction detection system and safety devices for correct operation**
- **All repair and service work to this product must be done by a suitably qualified person**

This product was designed and built strictly for the use indicated in this documentation. Any other use, not expressly indicated here, could compromise the good condition/operation of the product and/or be a source of danger!



CENTURION SYSTEMS (Pty) Ltd does not accept any liability caused by improper use, of the product, or for use other than that for which the automated system was designed.

Ensure that the customer is in possession of the User Guide and that you have completed the installation details in the back of the User Guide.



Sharecall number **0860-CENTURION**

(Please note that this number is only applicable if dialed from within South Africa)

Please visit **www.centsys.co.za**

for more information on the world-class products manufactured by Centurion Systems, as well as for details of your nearest agent

Centurion Systems (Pty) Ltd Head Office

Unit 13 Northlands Production Park
Epsom Avenue,
Johannesburg
Northriding
2196

PO Box 506
Cramerview
2060
South Africa

Tel: +27 (0)11 699 2400

Fax +27 (0)11 704 3412 or (0)11 462 6669

(Please omit the 0 when dialing from outside South Africa)

South African Branches and Regional Distributors

Bloemfontein	(0)51 430 0870
Cape Town	(0)21 552 9425
Durban	(0)31 701 9583
East London	(0)43 743 4923
Johannesburg Central/West Rand	(0)11 699 2400
Johannesburg East Rand	(0)11 397 6401
Kimberly	(0)53 832 3231
Nelspruit	(0)13 752 8074/5
Port Elizabeth	(0)41 581 6994/5
Pretoria	(0)12 349 1745
Vereeniging	(0)16 422 5667

