

ITEM NO.	Sales copy/QTY.	Title	drwnum	partnum
1	1	Universal Keytag V2 - Bo Type	0000.M.09.21_3	GTKEYTAG02
2	1	Lock Assembly	1050.M.09.01_4.expl	PCCL19-19
3	1	O-Ring, ID14 x 2	-	BB/OR-14 x 2
4	1	Camlock Logo Spacer	1050.M.01.09.28_6	1050M10928
5	1	Tilt Adaptor Pin Assy	1050.M.04.00_1	1050M04000
6	1	Tilt adaptor	1050.M.23_9	DOMCEN0068
7	1	Grommet	1050.M.01.50_3	DOMCEN0064
8	1	O-Ring, ID7 x 4	-	BB/OR-07X4
9	3	M6 Domed Nut (SS)	-	NDOMEM0600
10	1	Rear Housing (Powdercoated)	1050.M.01.44.drill_3	1050M144P0
11	1	Motor & Brake Assy V2	1050.M.01.02.00_9	1050M12000V2
12	1	Vector origin Collar Kit V1	-	1050M0161KIT
13	1	Piston Cap & Filter Assy	1050.M.01.47/8	----
14	1	DOSS Assy	1050.M.01.06.00_4	PCA10502V1
15	1	Wire harness assy	1050.M.01.07.00_9	WH1050M176
29	1	Body extrusion (cutting)	1050.M.01.40.cut_12	1050M01400

Material: See table
 - All dimensions in mm.
 - Deburr all sharp edges
 - General tolerances:
 Linear: ±0.125
 Shafts: -0.250 to 0
 Bores: 0 to 0.250
 Angular: ±2°
Corrosion protection: None
Drng. mass: g
Drawn by:
Last mod: 2004/08/13
Scale: Not to any scale
Part No: VEC40000V1

CENTURION
 Tel: (011) 699-2400
 Fax: (011) 704-3412
Title: Main Assy Explode (Sales)
Drng. No. & Revision: 1050.M.01.00_5.Expl 3

THE INFORMATION CONTAINED IN THIS DRAWING IS THE SOLE PROPERTY OF CENTURION SYSTEMS ANY REPRODUCTION IN PART OR WHOLE WITHOUT THE WRITTEN PERMISSION OF CENTURION SYSTEMS IS PROHIBITED

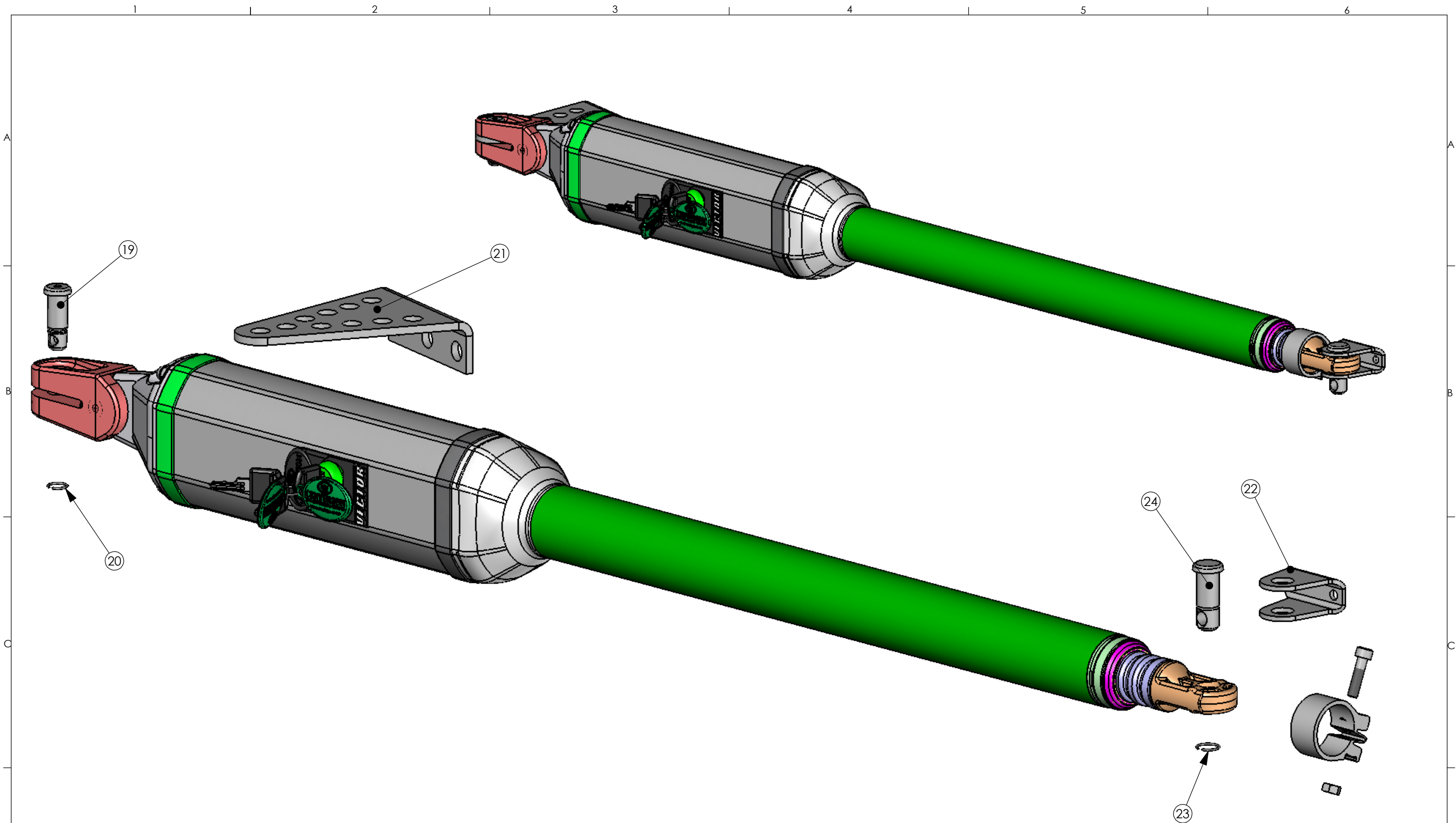

MOUNTING COMPONENTS

ITEM NO.	With wall brackets/QTY.	Title	drwnum	partnum
19	1	Wall bracket pin	1050.M.28_4	DOMCEN0071
20	1	Shaft snap ring 12mm, plated BN825	-	F1200SNAPR
21	1	Wall bracket (Standard)	1050.M.20_3	1050M20000
22	1	Gate bracket	1050.M.27_5	1050M27000
23	1	Shaft snap ring 14mm, plated BN825	-	F1400SNAPR
24	1	Gate bracket pin (High security)	1050.M.26_5	1050M26002
36	1	Body extrusion (cutting)	1050.M.01.40.cut_12	1050M01400

Material: See sheet 1	- All dimensions in mm. - Deburr all sharp edges - General tolerances: Linear: ± 0.125 Shafts: -0.250 to 0 Bores: 0 to 0.250 Angular: $\pm 2^\circ$	Drg. mass: 6215.0995414 Drawn by: TB/ GR Last mod: See sheet 1 Scale: Not to any scale Part No: VEC4000V1
---------------------------------	---	--

 CENTURION Tel: (011) 699-2400 Fax: (011) 704-3412	Title: SALES ref. Sheet 2 of 2 Linear Main Assembly with Peripherals Drg. No. & Revision: 1050.M.01.00_5.Exp11
---	--

THE INFORMATION CONTAINED IN THIS DRAWING IS THE SOLE PROPERTY OF CENTURION SYSTEMS ANY REPRODUCTION IN PART OR WHOLE WITHOUT THE WRITTEN PERMISSION OF CENTURION SYSTEMS IS PROHIBITED