



CENTURION
THE AUTOMATIC CHOICE

www.centsys.co.za



XTrac™

**XTrac sectional and tip-up
Garage Door Opener**

Installation Manual



**GARAGE DOOR
OPERATORS**



**SWING GATE
OPERATORS**



**SLIDING GATE
OPERATORS**



**REMOTE
CONTROLS**



INTERCOMS



SAFETY BEAMS



KEYPADS



Established 1986

Company Profile



1986



1990



1995



1999



Centurion Systems
Today

**In-house
R & D
development
team**



**Manufacture to
international
quality standard
ISO 9001:2008**



**100%
testing of
products**



**Competent
after-sales
technical support**



**Sales and support throughout
Southern Africa and over
50 countries worldwide**

CENTURION SYSTEMS (Pty) Ltd. reserves the right to make changes to the products described in this manual without notice and without obligation of CENTURION SYSTEMS (Pty) Ltd. to notify any persons of any such revisions or changes. Additionally, CENTURION SYSTEMS (Pty) Ltd. makes no representations or warranties with respect to this manual. No part of this document may be copied, stored in a retrieval system or transmitted in any form or by any means electronic, mechanical, optical or photographic, without the express prior written consent of CENTURION SYSTEMS (Pty) Ltd.



Contents



IMPORTANT SAFETY INSTRUCTIONS

1

1	Product warranty and exclusions	5
2	Assembly instructions	6
2.1	Identify Garage Door type	6
2.2	Identify installation method	6
2.3	Assembly	7
3	Installation instructions	10
3.1	Header bracket mounting	10
3.2	Towing bracket mounting	11
3.3	Attaching Drive Rail to header bracket	11
3.4	Mounting Drive Rail Assembly to ceiling	11
3.5	Attaching Bent Towing Arm	13
3.6	Connecting to Power Supply	13
3.7	Engaging / Disengaging	13
4	Settings and adjustments	15
4.1	Door travel adjustment	15
4.2	Safety obstruction force adjustment	16
4.2.1	Adaptive Mode	16
4.2.2	Manual Mode	18
5	Options and Features	20
5.1	Accessory Connections	20
5.2	Auto Close	20
5.3	Back Jump	21
5.4	Dual Power	21
5.5	Control Box	22
5.6	Courtesy Lamp	24
5.7	Dip Switches	24
5.8	Door Service Monitor	25
5.9	Remote controls	25
5.10	Wireless wall switch	26
5.11	Learn Button	26
5.12	LED Indicator	26
5.13	Run button	27
5.14	Safety beams	27
5.15	Safety reverse	28
5.16	Soft start	28

5.17	Soft stop	28
5.18	Speed control	28
5.19	Holiday lock-out mode	29
5.20	Maintenance	29
6	Technical specifications	30
7	Trouble shooting guide	31



IMPORTANT Safety Instructions

ATTENTION

To ensure the safety of people, it is important that you read all the following instructions. Incorrect installation or incorrect use of the product could cause serious harm to people. 

The installer, being either professional or DIY, is the last person on the site who can ensure that the operator is safely installed, and that the whole system can be operated safely.

- PLEASE READ CAREFULLY AND ADHERE TO ALL SAFETY AND INSTALLATION RECOMMENDATIONS**
- The installation of your new Automatic Garage Door Opener (herein after referred to as "XTrac") must be carried out by a technically qualified or licensed person. Attempting to install or repair the XTrac without suitable technical qualification may result in severe personal injury, death and / or property damage.
- The XTrac must only be installed on a properly balanced well functioning garage door. An improperly balanced or malfunctioning garage door could cause serious personal injury, death and / or property damage. Have a qualified person check and if required, make repairs to your garage door before installing the XTrac. The garage door is deemed to be well balanced and aligned if;
 - requires an equivalent amount of applied force to either manually open or a more than 150N (15kg) of applied force to either manually open or close, and
 - does not rise or fall more than 100mm when released at any point between fully open or fully closed positions, and
 - does not rub on or incorrectly make contact with any supporting or surrounding structures, and
 - the horizontal tracks have been installed level, and
 - the door panels have been installed level, and
 - the vertical tracks have been installed plumb, and
 - the junction between the curved horizontal track and the vertical track does not cause the door to "jump"
- The counter balance springs on sectional type garage doors must be properly lubricated between all of the coils with heavy automotive bearing grease.



Failure to adequately lubricate the springs may result in one or more of the following symptoms:

- a. Counter balance springs may become rusty over time resulting in additional operating friction between the coils which may cause the XTrac to malfunction.
 - b. Seasonal temperature changes may cause the garage door springs to expand and / or contract. The resultant increase and / or decrease in operating friction may cause the XTrac to malfunction. Properly lubricating the springs will help to minimize changes in operating friction due to the effects of seasonal temperature change.
5. Remove or render inoperative all existing locks and ropes prior to installation of the XTrac.
 6. Repairs to the garage door must be carried out by technically qualified persons. Attempting to repair the garage door without suitable technical qualification may result in severe personal injury, death and / or property damage.
 7. Where possible, install the XTrac at least two meters or more above the ground. Adjust the Engage / Disengage Cord so that it hangs approximately 1.8 meters from the ground.
 8. The Header Bracket carries ALL of the opening and closing thrust of the XTrac and as such must be securely fastened to a rigid, structural member of the garage wall or ceiling. It is entirely up to the installer to determine the fixing method and the structural suitability of the fixing points.
 9. The ceiling structure must be adequate to support the weight of the XTrac. It is entirely up to the installer to determine the structural suitability of the fixing points.
 10. The Engage / Disengage Instruction Tag must remain attached to the Engage / Disengage Cord.
 11. Locate the Wall Switch;
 - a. within site of the garage door, and
 - b. at a minimum height of 1.5 meters above the ground so that it remains out of the reach of small children, and
 - c. away from all moving parts of the garage door
 12. The Entrapment Warning Label must be secured in a prominent position adjacent to the wall switch.
 13. The XTrac must be connected to a properly earthed general purpose 220VAC power outlet which has been installed by a qualified electrical contractor.
 14. Do not connect the XTrac to the power outlet until this manual instructs you to do so.

15. Subsequent to installation and adjustment, the XTrac the garage door must stop and reverse direction when it comes into contact with a 35mm high solid object placed on the floor under the garage door.
16. The correct function of the Safety Obstruction Force System should be checked on a monthly basis.
17. Never use the XTrac unless the garage door is in full view and free from any object which may impede the movement of the garage door such as cars, children and / or adults.
18. Never allow children to operate the Xtrac.
19. Never operate the XTrac when any persons are under or near the path of the garage door. Children must be supervised at all times when near the garage door and when the XTrac is in use.
20. Never attempt to disengage the XTrac to manual operation when there are children / persons and / or solid objects including motor vehicles under or near the path of the garage door as the garage door may fall sharply upon Manual Release from the Xtrac.
21. Never attempt to open or close the garage door by pulling on the Engage / Disengage Cord.
22. Never attempt to make any repairs or remove covers from the XTrac without first disconnecting the power supply cord from main power supply.
23. Removal of the XTrac's protective covers must only be performed by a technically qualified person. Attempting to remove the protective covers or repair the XTrac without suitable technical qualification may result in severe personal injury, death and / or property damage.
24. For additional safety we strongly recommend the inclusion of Safety Beams. Although the XTrac incorporates a pressure sensitive Safety Obstruction Force system the addition of Safety Beams will greatly enhance the operating safety of an automatic garage door and provide additional peace of mind. In some countries it is a mandate of law to fit Safety Beams. It is the sole responsibility of the owner / installer to fit Safety Beams in those countries that so require.
25. Always ensure that the garage door is fully open & stationary before driving in or out of the garage.
26. Always ensure the garage door is fully closed and stationary before moving out of its view.
27. Adjustments to the Safety Stop / Reverse Force settings must only be carried out by a technically qualified person. Attempting to adjust the settings without uitable technical qualification may result in severe personal injury, death and / or property damage.
28. Keep hands and loose clothing clear of the XTrac and garage door at all times.



29. In order for the Safety Obstruction Force system to function it must first encounter an obstruction in the form of an object / person on to which some force MUST be exerted. As a result the object / person / garage door may suffer DAMAGE AND / OR INJURY.
30. The Safety Obstruction System is designed to work on STATIONARY objects only. Serious personal injury, death and / or property damage may occur if the garage door comes into contact with a moving object during an open or close cycle.

WARNING! WARNING! WARNING! WARNING! WARNING!



**KEEP CLEAR!
GATE MAY MOVE AT ANY TIME!**

**MOVING GATE CAN CAUSE SERIOUS INJURY OR DEATH!
KEEP CLEAR! GATE MAY MOVE AT ANY TIME!
DO NOT ALLOW CHILDREN TO PLAY IN AREA
OR OPERATE GATE.**

1. Product warranty and exclusions

All CENTURION products are manufactured with extreme care, thoroughly inspected and tested. All CENTURION products are warranted against faulty materials and workmanship for a period of 24 months from the date of invoice. However, it is expressly noted that batteries carry a six month warranty due to the nature of these products being such that they are subject to possible misuse which is beyond the control of Centurion Systems.

The warranty will cover the repair or replacement, at the discretion of Centurion Systems, of such faulty materials or parts free of charge provided that the equipment is returned to our workshop. The workmanship of the installation of the products carried out by any third party is specifically not covered under this warranty (please consult with your installer about their workmanship warranty terms and conditions). For equipment not of CENTURION's manufacture the warranty as supplied by the original manufacturer will apply.

No claims whatsoever will be recognised under the terms of this warranty which pertain to damage, injury, cost or expense, suffered by persons and / or to property, which either directly or indirectly arise out of any one of the following occurrences:

- a. Failure to install the product in accordance with the installation instructions provided by Centurion Systems.
- b. Failure to abide by the safety instructions provided by Centurion Systems.

This warranty will not apply to any equipment which:

- a. Has not been installed in accordance with the installation instructions provided.
- b. Has been subject to misuse or which has been used for any purpose other than that designed for by the manufacturers.
- c. Has damage caused as a result of handling during transit, atmospheric conditions (including lightning), corrosion of metal parts, insect infestation, power surges or other forces outside of the control of Centurion Systems.
- d. Has been repaired by any workshop and / or person NOT previously authorised by Centurion Systems.
- e. Has been repaired with components not previously tested, passed or authorised by Centurion Systems.

2. Assembly instructions

2.1 Identify Garage Door type

Identify the garage door type and then select the preferred installation method (Sec.2.2) and assembly type (Sec.2.3) that is best suited to the application.

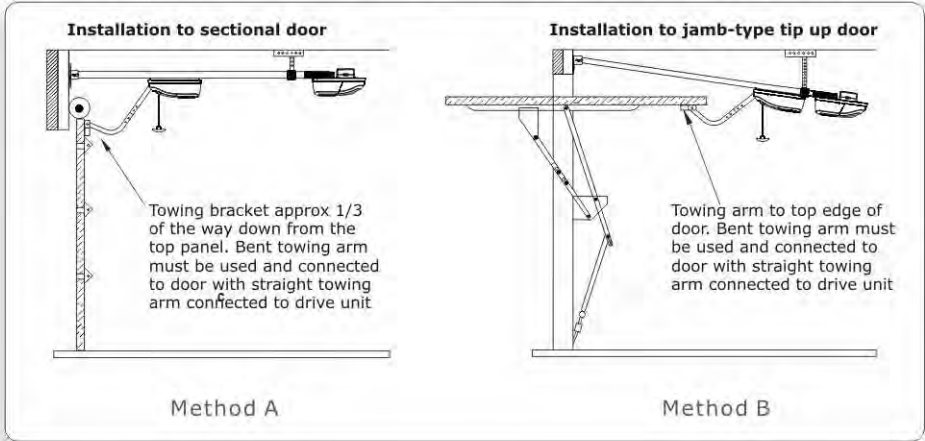

2.2 Identify installation method

Method A -(Sectional door)

- Use 3000mm long one piece or 3000mm three piece Drive Rail
- The standard 3000mm Drive Rail will lift a door up to 2440mm high. (optional Drive Rail extension kit is available for doors over 2440mm high)
- XTrac is supported by the Drive Rail Hanger which is hung from the ceiling by appropriate hanging material
- Header Bracket may be mounted on front wall of garage or on ceiling adjacent to the front wall

Method B -(Jamb type Tip-Up door)

- Use 2000mm single piece rail or make up using two rail sections from the three piece rail kit
- XTrac is supported by the Drive Rail Hanger which is hung from the ceiling by appropriate hanging material
- Drive Rail must be angled as shown depicted in "Method B" so that the underside of the Drive Unit is in line with underside of the garage door when the garage doors in the fully open (horizontal) position
- Header Bracket may be mounted on front wall of garage or on the ceiling adjacent to the front wall

2.3 Assembly

2.3.1 General assembly

- Open the packing carton and expose the XTrac components as depicted in Fig.1
- Orientate the Drive Rail (Fig.1-A) so that the Terminal Bracket (Fig.1-G) faces towards the garage door
- Locate the Drive Unit (Fig.1-C) and slide it into the Drive Rail and at the same time insert the Drive Chain (Fig.1-B) into the Drive Unit. Slide the Drive Unit at least 500mm in from the end of the Drive Rail
- Note: Before attempting to insert the Drive Chain into the Drive Unit ensure that the Drive Unit is disengaged (Refer Sec.10)
- Locate the Close Limit Prong (Fig.1-D) and slide it into the Drive Rail
- Locate the Drive Rail Hanger (Fig.1-E) and slide it around the outside of the Drive Rail. Make sure that the M8 dome head mounting bolts have been fitted to the Drive Rail Hanger
- Insert the Control Box (Fig.1-F) into the Drive Rail
- Insert the Drive Chain into the Tensioning Block (Fig.1A-F1) and then "Twist and Lock" the Drive Chain into place (Fig.1A-F2)
- Use a 12 mm socket wrench to tighten the Drive Chain Tensioner Bolt to the point where the underside of the Bolt Head aligns with the Indicator Arrow on the Terminal Bracket.(Fig.1B-G1)

Independent mounting of Control Box

With either of the methods A or B the Control Box may be mounted independently of the Drive Rail.

An optional instruction sheet and fitting kit;

- i. "FKA" is available for mounting the Control Box on the ceiling adjacent to the Drive Rail.
- ii. "FKB" is available for mounting the Control Box on a side wall of the garage.

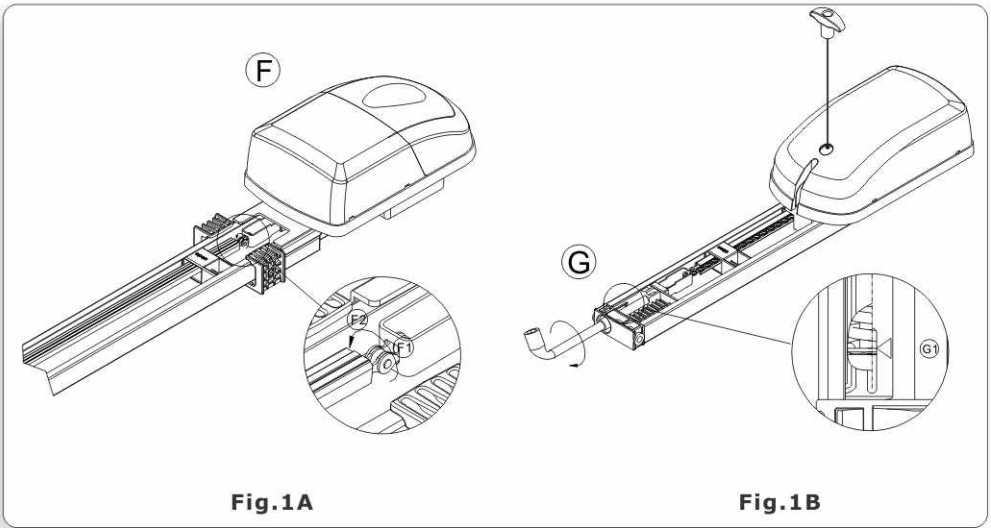
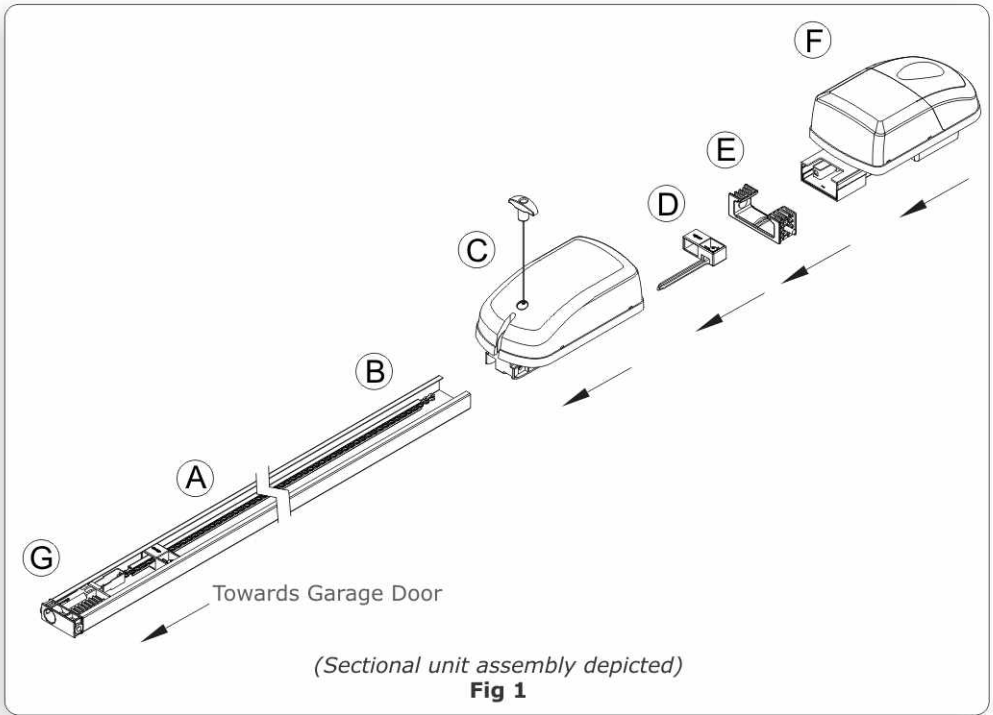

2.3.2 Attaching Straight Towing Arm

- Remove the Drive Unit cover (Fig.2) by pulling outwards and upwards, on both sides, at the location marked by the arrow.
- Insert the Straight Towing Arm through the slot in the cover (Fig.2A)

Note: use the end of the arm which has only one single hole.

- Attach the arm to the Drive Unit using the short clevis pin and spring clip provided (Fig.2A) and then replace the cover.

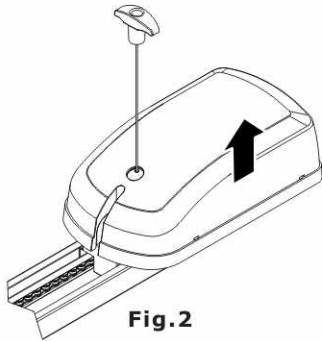

Fig.2

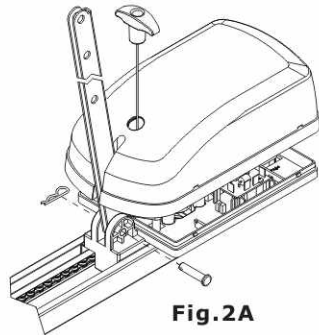

Fig.2A

2.3.3 Options selection

- Refer to Sec.5.7 – Dip switches and the sub section “functionality” and select the required dip switch functionality as required. Detailed explanation of the different functions is provided under “Options and Features” Sec 5.1 – 5.19.
- Refer to Sec.5.1 – Accessory Connections to determine the external accessory wiring that is required
- To access the Dip Switches and Accessory Connectors remove the Control Box cover (Fig.3) by first removing the fixing screw, located under the light cover and then pulling outwards and upwards, on both sides of the cover, at the location marked by the arrow
- Once functionality selection and wire connection has been completed replace the cover
- The XTrac is now fully assembled and ready for installation

Remove cover
fixing screw
under light
cover

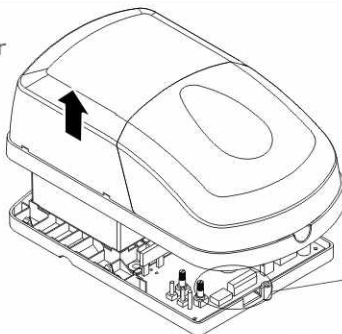
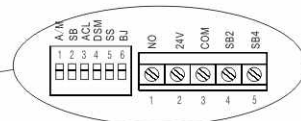

Fig.3



3. Installation instructions

3.1 Header bracket mounting

Important Note: Before commencing the installation ensure that you have carefully read and understood the Safety Recommendations outlined in pages 1 to 4 of this manual. In particular, ensure that the installation of the garage door complies with the requirements specified in points 3, 4 and 5. Make any necessary adjustments to the garage door **BEFORE** commencing the installation!

- Determine the highest arcing point of the garage door and mark this as a horizontal line on the header above the top edge of the garage door. (Figs.4 & 5)
- Determine the Garage Door Centre Line and mark a vertical line on the header above the door. (Fig.5)
- Place the Header Bracket on the wall as depicted in Fig.5 and ensure that the bottom edge of the bracket is no more than 50mm above the Highest Arcing Point. Mark the location of the two outer most screw holes
- Drill two screw holes and use screws of at least 8mm diameter. x 50mm long to secure Header Bracket to Header

Important notes:

- The Header Bracket carries ALL of the opening and closing thrust of the XTrac and as such must be securely fastened to a rigid, structural member of the garage. It is entirely up to the installer to determine the fixing method and the structural suitability of the fixing points.**
- Mounting the Drive Rail more than 50mm above the Highest Arcing Point of the garage door may cause the Drive Rail to flex excessively. Always ensure that the bottom edge of the Drive Rail is located within 50mm of the top edge of the top panel of the garage door. (Fig.7)**

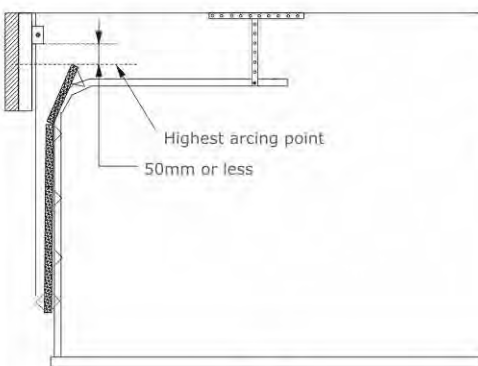

Fig 4

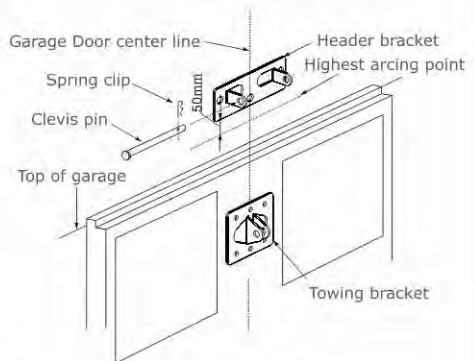

Fig 5

3.2 Towing bracket mounting

- Determine the Garage Door Centre Line (Fig.5) and affix the Towing Bracket to a structural member of the garage door. The Towing Bracket should be mounted with reference to the top edge of the garage door in accordance with the appropriate diagram as depicted in Sec.2.1 Method A or B
- Mark the location of the holes. (four holes if using self drilling screws – two holes if using screws with nuts)
- Drill the screw holes with an appropriate drill and securely mount the Towing Bracket to the garage door using screws of at least 6mm dia

Important notes:

- a. It is recommended to use fixing screws and nuts rather than self drilling screws.**
- b. For a sectional type garage door the pivot point of the Towing Bracket should be located approx one third of the way down from the top edge of the top panel. For a tip-up type garage door the pivot point should be as close to the top edge of the garage door as possible.**

3.3 Attaching Drive Rail to Header bracket

- With the garage door in the fully closed position - lay the assembled XTrac on the garage floor in line with the centreline of the garage door so that the Control Box is furthest from the garage door
- Important Note: avoid scratches and potential damage to the XTrac plastic covers by placing the Control Box and Drive Unit on cardboard or foam
- Raise the Drive Rail up to the Header Bracket so that the Drive Rail sits in between the ears of the Header Bracket. (Fig.6)
- Align the mounting holes of the Header Bracket and Terminal Bracket and fully insert the long clevis pin and secure it with the spring clip

3.4 Mounting Drive Rail assembly to ceiling

- Raise the Drive Rail assembly off the floor and rest it on a support high enough that the Drive Rail runs parallel to the ground. (Fig.7) depicts typical sectional type garage door installation)
- Important Note: Do not lift the XTrac by the Control Box or damage may occur. Always lift the XTrac via the Drive Rail
- Carefully open the garage door and ensure that no part of it comes into contact with the Drive Rail or the Control Box during its entire movement
- Align the Drive Rail with the centreline of the garage door.
- Slide the Drive Rail Hanger along the drive rail (up to max 600mm from the Control Box) in order to align it with a structural member of the garage. Securely fasten the Drive Rail Hanger to the structural member of the garage using two lengths of appropriate hanging material. (Fig.7)
- Once the Drive Rail is hung it should sit parallel to the floor along both planes. (For sectional doors only. For jamb-type tilt door refer page 6 Method B)

Important notes:

- a. With the garage door in the fully open position the underside of the Drive Rail should be no more than 50mm above the highest arcing point for its entire length. Mounting the Drive Rail more than 50mm above the Highest Arcing Point of the garage door may cause the Drive Rail to flex excessively. (Fig. 7)
- b. The ceiling structure must be adequate to support the weight of the XTrac. It is entirely up to the installer to determine the structural suitability of the fixing points.

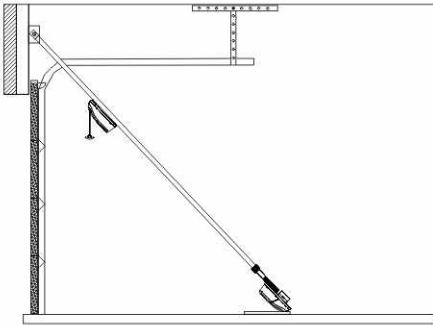

Fig. 6

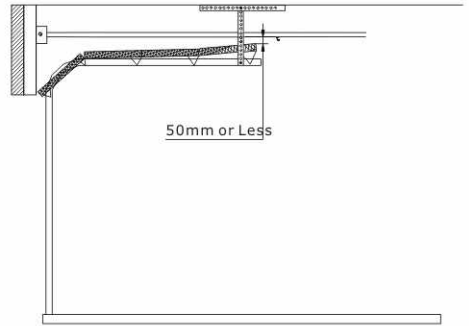

Fig. 7

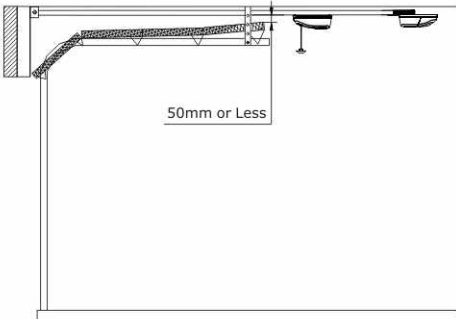

Fig. 8

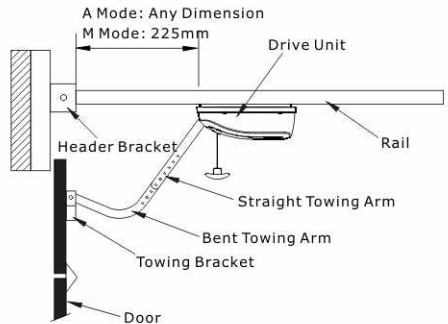

Fig. 9

3.5 Attaching Bent Towing Arm

- Close the garage door.
- Attach the Bent Towing Arm to the Towing Bracket (use the end of the arm which has only one hole)
- With the Drive Unit disengaged (Fig.10) position the Drive Unit in either one of the following ways;
 - i. Adaptive mode ~ any distance from the end of the Drive Rail.(Fig.9)
 - ii. Manual Mode ~ 225mm from the end of the rail to the front of the Drive Unit. (Fig.9)

Note: For explanation of adaptive and manual modes refer to section on obstruction force on page 16.

- Bring the Straight and Bent Towing Arms together and align the two furthest apart sets of holes

Important Note: The two arms should be connected in a way that makes them as long as possible.

- Securely fix the arms together using two 8mm screws and nuts

3.6 Connecting to power supply

- Plug the XTrac into a properly earthed 220 ~ 240 VAC power outlet
- Ensure that no excess power cord hangs below the Control Box

3.7 Engaging / Disengaging

- The unique engage / disengage mechanism provides the following features:
 - a. Positive garage door locking even during power outages.
 - b. Re-engagement in any position without the need to line up chain and carriage components.

Functionality

- TO DISENGAGE - pull down on the release handle (Fig.10) until a click is "felt" and then release the handle
- TO ENGAGE - pull down on the release handle once again until a click is "felt" and then release the handle

Important notes:

- a. Never attempt to open or close the garage door by pulling on the release handle. Doing so may result in **SERIOUS PERSONAL INJURY** and / or **PROPERTY DAMAGE**.
- b. Always disengage the XTrac with the garage door in the fully closed position.
- c. If attempting to disengage the XTrac from any position other than with the garage door fully closed ensure that there are no persons and / or property near or directly under the path of the door.

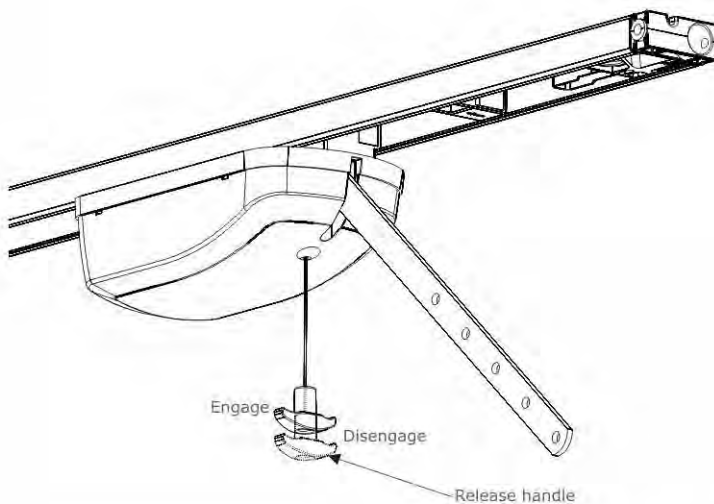

Fig 10

4. Settings and adjustments

4.1 Door travel adjustment

- The Drive Rail mounted Limit Prongs provide a one to one ratio between Limit Prong movement and garage door movement thereby ensuring 100% accuracy and ease of adjustment. Garage door fully open and fully closed positions can be easily adjusted by moving the Limit Prong to the desired location in order to increase or decrease garage door travel

Door travel adjustment – Close direction

- Locate the Close Direction Limit Prong within the Drive Rail - nearest to front wall of garage (Fig.11)
- Loosen the Limit Prong Lock Screw by half a turn and slide the Limit Prong towards the front wall of the garage to increase garage door travel and away from the front wall to decrease garage door travel
- Re-tighten the Limit Prong Lock Screw once correct adjustment has been attained
- Note: The Limit Prongs work on a one to one ratio with the garage door, meaning that if the Limit Prong is moved by 10 mm then the garage door will also move by 10 mm

Door travel adjustment – Open direction

- Locate the Open Direction Limit Prong within the Drive Rail – nearest to Control Box. (Fig.11)
- Loosen the Limit Prong Lock Screw by half a turn and slide the Prong towards the Control Box to increase garage door travel and away from the Control Box to decrease travel
- Re-tighten the Limit Prong Lock Screw once correct adjustment has been attained

Note: The Limit Prongs work on a one to one ratio with the garage door - meaning that if the Limit Prong is moved by 10 mm then the garage door will also move by 10 mm.

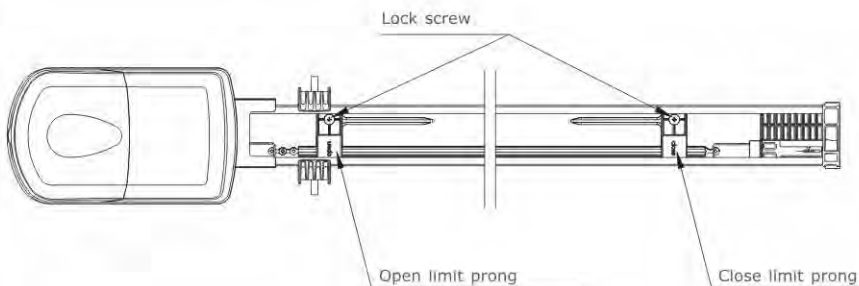

Fig.11

4.2. Safety obstruction force adjustment

- Dual Safety Obstruction Force Adjustment modes ensure that the XTrac can be optimized to suit virtually any sectional or tip-up type garage door
- **Adaptive mode** – constantly monitors incremental drive force value changes that occur due to seasonal conditions and / or garage door aging. Adaptive Mode compensates for these variables by automatically adjusting Safety Obstruction Force values during every complete cycle, resulting in enhanced safety and minimized chances of garage door *ghosting. (Refer Sec.4.2.1 for set-up details)
- *Ghosting is defined as a Safety Stop or Safety Reverse without the garage door actually encountering an obstruction
- **Manual mode** – features conventional one time Safety Obstruction Force value adjustment and is more suited for use on badly worn or improperly balanced garage doors. (Refer Sec.4.2.2 for set-up details)

4.2.1 Adaptive (A) mode

Enabling

- If Manual Mode is your desired selection then skip to Sec.4.2.2
- If Adaptive Mode is already enabled then skip to the next section titled "Functionality"
- To enable Adaptive Mode carry out the following procedure;
 - i. switch off power at power supply.
 - ii. remove the Courtesy Lamp and Control Box Covers to expose the Control Board (Refer Sec.5.6 for removal and replacement details).
 - iii. select Dip switch No.1 to the "ON" position (Fig.15).
 - iv. replace the Control Box and Lamp Covers.
 - v. switch power on at power supply.

Functionality

- In order to learn the required run time and drive force values the XTrac will be required to complete five (manually activated) uninterrupted open and close cycles.(commencing from the Close Limit Point)
- During the course of the cycles the LED Indicator will quick flash and the operating parameters will be learned in the following order;
 - i. Open Stroke 1 – Alignment stroke.
 - ii. Close Stroke 1 – Learn run time between Open Limit Point and Close Limit Point (during Close Cycle 1 the XTrac will not Slow Stop).
 - iii. Open Stroke 2 – Learn run time between Close Limit Point and Open Limit Poi.nt (during Open Cycle 1 the XTrac will not Slow Stop)
 - iv. Close Stroke 2 – Learn Drive Force Values between Open Limit Point and Close Limit Point.
 - v. Open Stroke 3 – Learn Drive Force Values between Close Limit Point and Open Limit Point.
- Once Learning has been successfully completed, the LED Indicator will commence to slow flash

Important note: During initial power-up learning, the Safety Obstruction Force values of the XTrac default to a maximum setting. Encounter a solid obstruction during the course of the initial learning cycles may result in garage door damage. It is recommended that initial learning cycles be carefully supervised in order to prevent the possibility of the garage door hitting an obstruction causing personal and / or property damage.

Safety Obstruction Force Adjustment

- Hinge open the Courtesy Lamp Cover (Fig.17) to expose the adjustment controls
- Rotate the (green) "Offset" Adjustment Pin (Fig.17-G) in a clockwise direction to increase Safety Obstruction Offset Value and in an anti clockwise direction to decrease the value
- The Safety Obstruction Offset Value may be adjusted within a range of 30N (3kg) ~ 100N (10kg)
- The selected value remains identical for both open and close direction travel

Testing open direction safety obstruction force value

- With the garage door in the fully closed position – stand in the middle of the garage doorway and just behind the path of the garage door
- Activate the XTrac so that the garage door begins to open
- When the garage door has opened to approx 450mm from the ground apply some firm downward force to one of the structural members of the garage door
- If the Safety Obstruction Force Value is correct the XTrac will stop (Safety Stop) the garage door upon sensing the applied force. If too little or too much force is required to make the XTrac stop - turn the (green) "Offset" Adjustment Pin (Fig.17 - G) five degrees in the appropriate direction - clockwise to increase force - anti-clockwise to decrease force - and then repeat the previous testing steps

Testing close direction safety obstruction force value

- With the garage door in the fully open position - stand in the middle of the garage doorway and just behind the path of the garage door
- Ensure that the Close Limit Travel Adjustment (Sec.4.1) has been set so that bottom of the garage door is resting firmly against the ground
- Place a 32mm thick block of wood under the line of the garage door (approx at the midpoint of the garage door) so that the garage door will close onto the block of wood
- Activate the XTrac so that the garage door begins to close
- If the Safety Obstruction Force Value is correct the XTrac will stop and reverse the direction of the garage door (Safety Reverse) upon encountering the block of wood.
- If too little or too much force is required to make the XTrac Safety Reverse - turn the (green) "Offset adjustment Pin (Fig.17-G) five degrees in the appropriate direction - clockwise to increase force - anti-clockwise to decrease force - and then repeat the previous testing steps

Forced learn

- A Forced Learn may be initiated by holding down the Learn" Button (Fig.17-D) for two seconds – LED Indicator will begin to quick flash
- Cycle the XTrac through five complete uninterrupted strokes (commencing from the close limit point) in order for it to complete the learning process
- The LED Indicator will cease to quick flash once learning has been completed

Important Note: During a Forced Learn the Safety Obstruction Force values default to a maximum setting. Encounter a solid obstruction during the course of the initial learning cycles may result in garage door and / or property damage. It is recommended that the learning cycles be carefully supervised during this time.

Automatic Re-Learn

- A re-learn of Drive Force and Run Time parameters will be automatically initiated immediately subsequent to either one of the following occurrences;
 - a. Run Time deviation becoming excessive
 - b. Safety Reversing on three consecutive occasions
 - c. Safety Stopping on three consecutive occasions
- During this period the LED Indicator will quick flash

4.2.2 Manual (M) mode

Enabling

- If Adaptive Mode is your desired selection, then refer to Sec.4.2.1 To enable Manual Mode;
 - i. switch off power at power supply
 - ii. remove the Courtesy Lamp and Control Box Covers to expose the Control Board (Refer Sec.18 for removal and replacement details)
 - iii. select Dip switch No.1 to the "OFF" position (Fig.15)
 - iv. replace the Control Box and Lamp Covers
 - v. switch power on at power supply

Entering safety obstruction force adjustment mode

- Hinge open the Courtesy Lamp Cover to expose the adjustment controls. (Fig.17)
- Press and hold down the "Learn" Button (Fig.17-D) for two seconds - LED Indicator will commence a paused double flash.
- Safety Obstruction Force adjustment can be carried out while LED Indicator is "paused double flashing"
- To close out Safety Obstruction Force Adjustment Mode momentarily press "Learn" Button

Note: Mode will close out automatically after 10 minutes if not closed out manually beforehand.

Safety Obstruction Force Adjustment – Open Direction

- Hinge open the Lamp Cover (Fig.17-A) to expose the adjustment controls
- With the garage door in the fully closed position - press the black "Run" Button (Fig.17-G) so that the garage door begins movement in the open direction
- As the garage door is opening slowly turn the (green) Open / Offset Adjustment Pin (Fig.17-G) in an anti-clockwise direction until the garage door stops
- Now turn the same pin clockwise five degrees.

Testing Safety Obstruction Force – Open direction

- With the garage door in the fully closed position - stand inside the garage just behind the path of the garage door close to its middle position
- Press the black "Run" Button (Fig.17-G) so that the garage door begins to open
- When the garage door has opened by approx 450mm apply some firm downward force to one of its structural members
- If the Safety Obstruction Force Adjustment is correct the XTrac will stop the garage door upon sensing the applied force
- If too little or too much force is required to make the XTrac stop - rotate the (green) Open / Offset Adjustment Pin five degrees in the appropriate direction (clockwise to increase force, anti-clockwise to decrease force) and then repeat the previous testing steps

Safety Obstruction Force Adjustment – Close direction

- With the garage door in the fully open position, press the black "Run" Button (Fig.17-F) so that the garage door begins to close
- As the garage door is closing - slowly turn the (red) Close / Speed Adjustment Pin (Fig.17-F) in an anti-clockwise direction until the garage door stops and begins to Safety Reverse
- Now turn the same pin clockwise five degrees

Testing Safety Obstruction Force – Close direction

- With the garage door in the fully open position stand inside the garage just behind the path of the garage door close to its middle position
- Ensure that the Close Limit Travel Adjustment (Sec.4.1) has been set so that bottom of the garage door is resting firmly against the ground
- Press the black "Run" Button so that the garage door begins to close
- Place a 32mm thick block of wood under the line of the garage door (approx at the midpoint of the garage door) so that the garage door will close onto the block of wood.
- If the Safety Obstruction Force Adjustment is correct the XTrac will stop and reverse the direction of the garage door upon sensing the block of wood
- If the XTrac stops but does not reverse then turn the (red) Close / Speed Adjustment Pin five degrees in an anti-clockwise direction. (Fig.17-F)

5. Options and features

5.1 Accessory connections

- Six Output Terminals are provided to support the connection of the most common external accessories
- The Output Terminals can be accessed by removing the Courtesy Lamp and Control Box Covers. (Refer Sec.5.6 for removal and replacement details)
- Connection Diagrams
 - a. XTrac two wire safety beam (Fig.12a)
 - b. CENTURION i5 or equivalent four wire Safety Beams (Fig.12b)
 - c. 24VDC universal receiver (Fig.13)
 - d. Normally open momentary contact Wall Switch (Fig.14)

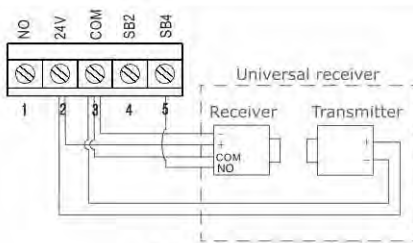

Fig 12a

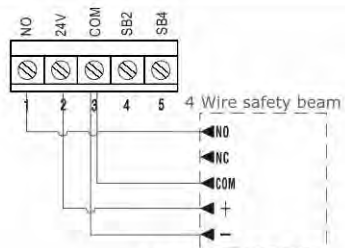

Fig 13

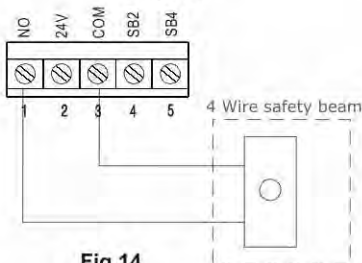

Fig 14

Important note: The max current draw with all accessories connected should not exceed 150mA

5.2 Autoclose

- Autoclose can enhance the security of your property by ensuring that your garage door is never unintentionally left open
- Autoclose will automatically close the garage door;
 - i. Three seconds after reaching the open limit point - provided that a person or object has passed through the Safety Beams during the open cycle, or
 - ii. upon expiry of the pre set 30 seconds delay time - provided that a person or car has not passed through the Safety Beams within the delay time.

Important note: Autoclose will only function when used in conjunction with Safety Beams.

Enabling

- i. Remove the Courtesy Lamp and Control Box Covers to expose the Control Board (Refer Sec.5.6 for removal and replacement details).
- ii. Select Dip Switch Nos.2 (SB) and 3 (AC) to the "ON" position. (Fig.14).
- iii. Replace the Control Box and Courtesy Lamp Covers once selection has been completed.

5.3 Back jump

- Back Jump will reverse the closed garage door by an incremental amount (1 ~ 5mm) in order to reduce motor gear lock up and ensure effortless disengagement in the event of power outage

Enabling

- Remove the Courtesy Lamp and Control Box Covers to expose the Control Board (Refer Sec.5.6 for removal and replacement details)
- Select Dip Switch No.6 (BJ) to the "ON" position. (Fig.15)
- Replace the Control Box and Courtesy Lamp Covers

5.4 Dual powered XTrac

- The Dual Powered XTrac has built-in batteries which provide back-up power in the event of a power outage
- The batteries can provide up to 30 complete cycles of operation while the power supply is not active

Important Note: Batteries will suffer permanent damage if not charged within a three month while remaining connected to the controller.

5.4.1 LED indicator

- Will display green when power supply is active (Fig.17-C)
- Will display red when power supply is not active
- Will extinguish when XTrac enters Shut-Down Mode

5.4.2 Shut-Down mode

- In the event of prolonged power outage the XTrac will automatically shut down (when battery voltage drops below 23 volts) in order to conserve remaining voltage - LED Indicator (Fig.17-C) will extinguish and the XTrac will cease to function

Automatic Shut-Down

- Shut-down will only occur when the power supply is not active
- Prior to shutting down a warning buzzer will;
 - a. Single "beep" every 30 seconds to indicate that power supply is not active.
 - b. Double "beep" every 30 seconds to indicate that the power supply is not active and that remaining battery voltage is low therefore Shut-Down is imminent.
 - c. Once the power supply becomes active the green LED Indicator will illuminate.

Manual Shut-Down

- To manually shut down the XTrac perform the procedure as follows;
 - i. press and hold Learn Button.
 - ii. whilst continuing to hold down the Learn Button, press and hold Run Button.
 - iii. XTrac will have entered Shut-Down Mode once the LED extinguishes.

5.4.3 Solar power

- An optional Solar Power kit is available. Contact Centurion Systems for further information

5.4.4 Warning buzzer

- An audible buzzer will;
 - a. Single “beep” every 30 seconds to indicate that the power supply is not active.
 - b. Double “beep” every 30 seconds to indicate that the power supply is not active and that remaining battery voltage is low therefore Shut-Down is imminent.

5.5 Control box

- The Control Box houses most of the controls from which the XTrac may be adjusted and functionality customized to suit individual requirements
- Most commonly used functionality controls are accessible from within the Courtesy Lamp Cover
- Less commonly used controls are accessible by removing both the Courtesy Lamp and Control Box Covers to expose the Control Board

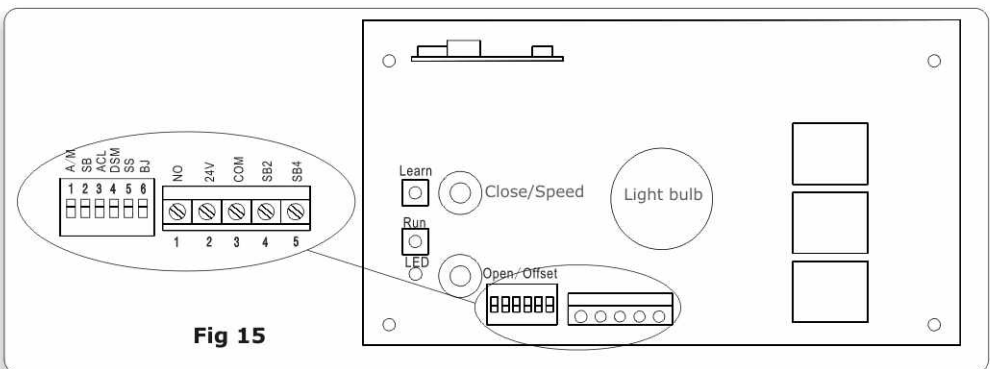

Fig 15

Removal and Replacement of Courtesy Lamp and Control Box Covers

Important Note: The control board and power supply contain high voltage components. Coming into contact with these components may cause severe injury or death. Always switch of the XTrac and unplug the power cord BEFORE removing the main Control Box cover. The Control Box cover should only be removed by a suitably qualified technician

- Remove Courtesy Lamp and Control Box covers as follows;
 - i. Switch off XTrac at power point and unplug the power cord.
 - ii. open the Courtesy Lamp cover by pulling it down at the finger recess point (Fig.16–A).

- iii. remove the Control Box cover Lock Screw point (Fig.17-B) Note: the Control Box Cover can be removed once the head of the screw is protruding by approx 5mm.
- iv. remove the Control Box cover by pulling first outwards and then downwards at the finger recess points (Fig.16-B & C).
- Replacement of all components is the reversal of removal. the delay time

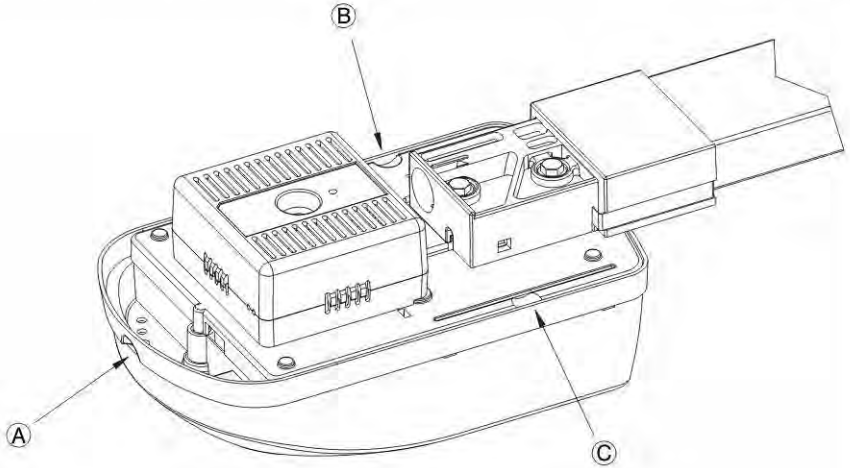

Fig 16

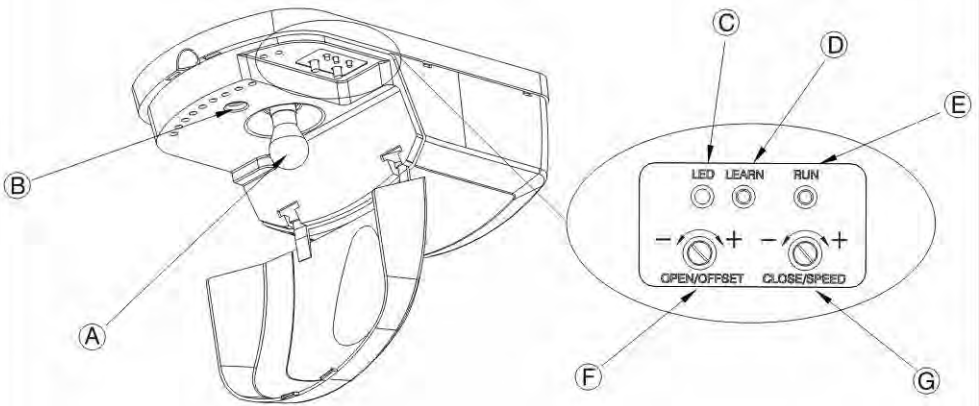

Fig 17

5.6 Courtesy lamp

- The in-built Courtesy Lamp will switch on each time the XTrac is activated and then switch off automatically 90 seconds after receiving the last Hand Transmitter or run signal.
- In order to conserve remaining battery power the Courtesy Light will not function once battery voltage falls below 24V

Bulb replacement

- Hinge open the Courtesy Lamp Cover to expose the bulb (Fig.17-A)
- Remove the bulb by first pushing-in and then turning anti clockwise (same as removing and replacing a household light bulb)
- Replace bulb with identical 24V 21W Incandescent
- Close the Courtesy Lamp cover

Important note: Replacing the bulb with 12V version will cause the transformer to overheat and may permanently damage the transformer and Control Board. Always ensure that replacement bulb is rated at 24V and no more than 20W.

5.7 Dip switches

- The Dip Switches located on the Control Board (Fig.16) enable or disable specific functionality
- The Dip Switches can be accessed by removing the Courtesy Lamp and Control Box Covers (Refer Sec.5.6 for removal and replacement details)
- Read through the following table and select the specific functionality best suited your specific personal or garage door requirements. nt of all components is the reversal of removal. the delay time

Functionality table

Function	Dip No.	Dip Position	Details
Adaptive Mode (A/M) – Enable	1	ON	Sec.4.2.1
Manual Mode (A/M) – Enable	1	OFF	Sec.4.2.2
Safety Beams (SB) - Enable	2	ON	Sec.5.14
Safety Beams (SB) – Disable	2	OFF	Sec.5.14
Autoclose (AC) - Enable	2 & 3	ON	Sec.5.2
Autoclose (AC) – Disable	3	OFF	Sec.5.2
Door Service Monitor (DSM) – Enable	4	ON	Sec.5.8
Door Service Monitor (DSM) – Disable	4	OFF	Sec.5.8
Soft Stop (SS) – Enable	5	ON	Sec.5.17
Soft Stop (SS) – Disable	5	OFF	Sec.5.17
Back Jump (BJ) – Enable	6	ON	Sec.5.3
Back Jump (BJ) – Disable	6	OFF	Sec.5.3

Enabling

- Remove the Courtesy Lamp and Control Box Covers to expose the Control Board (Refer Sec.5.6 for removal and replacement details)
- Select the Dip Switches as required to enable the desired functionality (Fig.15)
- Replace the Control Box and Courtesy Lamp Covers

5.8 Door Service Monitor (DSM)

- Door Service Monitor will monitor the spring balance of the garage door by logging the run time differential between open and close cycles.
- The Courtesy Lamp will triple flash once every 15 seconds once the run time differential exceeds three seconds. At this point the garage door should be serviced by a suitably qualified technician.

Important note: Door Service Monitor function is available only when Adaptive Mode has been selected.

Enabling

- Remove the Courtesy Lamp and Control Box Covers to expose the Control Board (Refer Sec.5.6 for removal and replacement details)
- Select Dip 4 (DBM) to the "ON" position, (Fig.15)
- Replace Control Box and Courtesy Lamp Covers

5.9 Remote controls

- The CENTURION rolling code (Keeloq™ encryption) remote control provides state of the art security by providing up to 1.2 billion possible code combinations. A new digital code is generated each time the remote control is pressed thereby ensuring the total security of your garage and its contents from potential coded scanning devices. Up to 22 individual remote control buttons codes may be stored.

Code learning

- Remote controls may be coded as follows;
 - i. hinge open the Courtesy Lamp Cover to expose the "Learn" Button (Fig.17).
 - ii. locate one of the remote controls supplied with the XTrac.
 - iii. momentarily press the "Learn" Button (Fig.17-D) – LED Indicator will glow solid (Fig.17-C).
 - iv. momentarily press the remote control button – LED Indicator will extinguish.
 - v. momentarily press the remote control button again – LED Indicator will begin to quick flash rapidly - programming is completed once the LED Indicator ceases to quick flash.
 - vi. close the Courtesy Lamp Cover.

Code deleting

- All remote control codes may be deleted as follows;
 - i. hinge open the Courtesy Lamp Cover to expose the "Learn" Button (Fig.17).
 - ii. momentarily press the "Learn" Button (Fig.17-D) – LED Indicator (Fig.17-C) will glow solid.
 - iii. press and hold the black "Run" Button – LED indicator will begin to rapid flash.
 - iv. all remote control codes will have been deleted once the LED indicator ceases to flash.
 - v. close the Courtesy Lamp Cover.

Remote control battery replacement

- Refer to instruction leaflet provided with CENTURION remote control

5.10 Wireless wall switch

- The wireless wall switch provided with the XTrac kit provides ease of installation without the need for running hard wires to the switch. It can be mounted in a convenient location such as adjacent to a side entry door into the garage. The four buttons provided on the wall switch are for independently operating from one wall switch, the two openers of a double garage door installation. The buttons can be used for activating the various function provided by the system
- Door open and close
- Activate light
- Electronically lock the door
- Override the Autoclose function

Mounting

- The switch can be permanently screwed to the wall through the mounting holes provided or alternatively “hooked” on the wall, providing the convenience of easy demount ability, through the “hook” holes provided on the base plate
- Use the mounting template and mounting instructions provided with the switch
- The Wireless Wall Switch may be learned into the XTrac as per the procedure outlined on Sec.5.8 “Code Learning”

Important note: The wireless Wall Switch must be mounted within sight of the garage door and a reasonable distance away from moving parts. It should be mounted at least 1500mm above the ground and the Entrapment Warning Label provided, must be attached adjacent to the switch.

5.11 Learn Button

- The “Learn Button” (Fig. 17 - D) is located within the Lamp Cover adjacent to the “Learn LED” and serves to initiate the functions as described in the following table:

Function	Action
Learn remote control code	Formal Force Learning
Formal Force Learning	Press and hold for two seconds
Sleep Mode	Sleep Mode
	Press and hold in conjunction with “Run” Button

5.12 LED Indicator

- The LED Indicator (Fig.17-C) is located under the Courtesy Lamp Cover and serves to indicate the functions as described in the following tables;

LED Display

- Provides visual indication of functionality sequences as described in the following table;

Display	Indicator
Glow Solid	Reached close limit position.
Slow Flash	Reached open limit position.
Medium Flash	Learning or deleting remote control codes
Quick Flash (A Mode)	Learning new drive force parameters
Quick Flash (M Mode)	Force adjust mode activated
Sleep Mode	Intermittent Flash

LED Colour

- Provides visual indication of whether power supply is active or not;

Colour	Indicator
Green	Power supply active
Red	Power supply inactive

5.13 Run Button

The black "Run" Button (Fig.17-E) is located under the Lamp cover and serves to initiate the functions as described in the following table;

Function	Action
Activate XTrac	Momentary press
Safety Beam override	Press and hold until garage door is fully closed
Sleep Mode	Press and hold in conjunction with "Learn" Button

5.14 Safety Beams

- The CENTURION i5 or other four wire Safety Beams may be connected to the XTrac.
- The installation of Safety Beams greatly enhances safety by constantly monitoring for persons or objects which may pass within the path of the moving garage door.
- The XTrac will commence to Safety Reverse if the Safety Beams become momentarily or permanently interrupted during a Close Cycle

Mounting

- Mark the inside garage door framing so that the bottom edge of the i5 beam sits 125mm off the floor
- Using a small angle bracket fasten each beam to the wall so that they face each other across the garage door

Connection

- Follow Safety Beam instructions and connect to the Output Terminals depicted in Fig.12. Use the normally open contacts of the beam to connect to input SB4 on the XTrac (Fig 12)

Important note: XTrac provides 24VDC output and Normally Open input.

Alignment

- Adjust the Safety Beam module marked "Transmitter" (by turning the mounting bracket) so that it is aimed directly at the lens of the Safety Beam module marked "Receiver". A GREEN indicator lamp located on the "Receiver" will glow once the correct alignment has been achieved
- Test the Safety Beam alignment several times each time ensuring that when the Safety Beams are obstructed the green indicator lamp extinguishes and when unobstructed the indicator lamp glows solid
- Firmly tighten the Safety Beam mounting bracket fixing screws
- Installation of the Safety Beams is now complete

Enabling

- Remove the Courtesy Lamp and Control Box Covers to expose the Control Board (Refer Sec.5.6 for removal and replacement details)
- Select Dip 2 (SB) to the "ON" position (Fig.15)

Testing

- Initiate a close cycle. As the garage door is closing interrupt the Safety Beams by passing an object through the line of the Safety Beams. If the Safety Beams are functioning correctly the XTrac should stop and then immediately reverse direction
- If the garage door commences a close cycle but within one cycle and reverses, check that the Safety Beams are aligned correctly as outlined in "Alignment"

Override

- In the event of a Safety Beam malfunction the garage door can be closed by pressing and holding the black "Run" Button (Fig.17-E) until such time as the garage door is fully closed and has stopped
- Note: If the black "Run" Button is released prior to the garage door reaching the fully closed position the XTrac will Safety Reverse

5.15 Safety reverse

- Partial Safety Reverse ensures that the garage door does not open fully and thereby present an unwanted security risk
- In the event that the garage door encounters a sufficient obstruction during a close cycle the XTrac will immediately stop and then begin to reverse direction and then stop after three seconds. Upon receiving a Signal immediately subsequent to partial Safety Reverse, the XTrac will recommence movement in the open direction

5.16 Soft start

- When commencing movement from any stationary position, the XTrac will slowly ramp up to full speed. This is in order to minimize start-up load on the XTrac and garage door and provide smooth and quiet operation

5.17 Soft stop

- By intelligently reducing the speed of the garage door as it approaches a limit point, the XTrac ensures quieter garage door closing and enhanced XTrac and garage door life. (Standard function within Adaptive Mode only)
- Adaptive Mode is factory configured to provide soft stopping prior to reaching a limit point. However, for garage doors that are improperly balanced it may be necessary to disable the soft stop function in order for the garage door to fully close or fully open
- Soft Stop is available only when adaptive mode has been selected

Enabling / Disabling

- i. Remove the Courtesy Lamp and Control Box Covers to expose the Control Board (refer Sec.5.6 for removal and replacement details)
- ii. TO ENABLE – select Dip Switch No.7 (SS) to the "ON" position (Fig.15)
- iii. TO DISABLE – select Dip Switch No.7 (SS) to the "OFF" position (Fig.15)
- iv. Replace the Control Box and Courtesy Lamp Covers once selection has been completed.

5.18 Speed control

- Running speed may be adjusted within the range of 70 ~ 100% of maximum speed
- Note: Available only when Adaptive Mode has been selected

Adjustment

- To enter Speed Control adjustment mode;
 - i. Move the Drive Unit so that it is positioned mid way between the two Limit Adjust Prongs (Fig.11)
 - ii. Hinge open the Courtesy Lamp Cover to expose the adjustment controls

- iii. Press and hold the "Learn" Button (Fig. 17-D) for two seconds in order to initiate Forced Learn – LED Indicator will begin to quick flash
 - iv. Rotate the (red) "Speed" Adjustment Pin (Fig.17-F) in a clockwise direction to increase running speed and anti-clockwise to decrease running speed
 - v. Close the Courtesy Lamp cover once adjustment has been completed
- Running speed may only be adjusted while the Drive Unit is travelling between Limit Points.
 - Speed Control adjustment will close out automatically once the Drive Unit reaches either one of the Limit Adjust Prongs.

5.19 Holiday Lockout mode

- During Holiday Lockout mode all functionality is disabled and the XTrac will only function upon receiving a signal from a pre-learned remote control
- Holiday Lockout Mode will not function unless at least one remote control has been previously learned into the XTrac

Entering / Exiting

- i. Hinge open the Courtesy Lamp cover to expose the adjustment controls (Fig.17)
- ii. TO ENTER - press and hold down the "Learn" Button (Fig.17-D) and whilst continuing to hold down the "Learn" Button press the black "Run" Button. (Fig.17-E)
- iii. TO EXIT - activate the XTrac with one of the pre-learned remote control

5.20 Maintenance

- Once every six months;
 - i. spray the inside of the Drive Rail (Fig.3 Item A) along its entire length with a light coating of WD40 or silicone spray lubricant.
 - ii. disengage the XTrac from the door (Fig.10) and then test the door to ensure that it meets with the requirements detailed on page 5 Items 3 and 4

6. Technical specifications

XTrac garage door operator (for sectional and tip-up doors)

Input voltage	180 – 270V AC @ 50/60Hz*
Motor voltage	24V DC
Motor power - rated	120W DC
Motor supply	Dual power – 250VA max. mains power supply, with 2 x 1.5Ah 24V battery backup supply
Max door width	6500mm
Max door area	12m ²
Max lifting capacity	1200N
Operations in standby mode	12 to 30 depending on the door size / weight / height / duration of power failure
Operator travel speed	Adjustable – between 90 – 125mm/sec
Door travel adjustment	Manually adjustable limits with 1 to 1 adjustment ratio
Safety obstruction force system	Selectable Manual / Adaptive
Light	Bayonet 24V 21W
Autoclose◊	Dip switch selectable
Infrared safety beams	Optional, but recommended
Radio receiver	CENTURION rolling code (Keeloq™ encryption) 433MHz
Receiver code storage capacity	22 transmitter buttons

* Can operate off a solar supply, consult **Centurion Systems** for assistance

◊ Requires infrared safety beams to be fitted

Specifications subject to change without prior notice

7. Trouble shooting guide

Symptom	Suggested Remedies/Reasons	Reference	
		Page	Sec.
• XTrac will not function at all	• Check that power chord is plugged-in and turned on	~	~
	• Check power point by plugging-in an alternate appliance	~	~
	• Check that XTrac is engaged to door	10	1.3
	• No LED display indicates that XTrac has entered Shut-Down Mode due to low battery voltage - check power supply (battery version only)	21	5.4
	• Opener may have entered Holiday Lock-out Mode	29	5.19
• Xtrac runs very slowly	• Speed Control setting may be too low - increase speed setting	28	5.18
	• Batteries are running low - check that charger is charging	21	5.4
	• Garage door may be binding or out of balance	1	1.3
• Door stops before reaching fully open position	• Disengage XTrac from door and check for obstructions	10	1.3
	• Disengage XTrac from door and check for correct spring balance	1	1.3
	• Check for correct Safety Obstruction Force adjustment settings	16	4.2
	• Check for correct Open Limit adjustment	15	4.1
	• Door may be incorrectly balanced - disable soft stop	28	5.17
• Door stops & reverses before reaching fully closed position	• Disengage XTrac from door and check for obstructions	10	1.3
	• Disengage XTrac from door and check for correct spring balance	1	1.3
	• Check for correct Safety Obstruction Force adjustment settings	16	4.2
	• Check for correct Open Limit adjustment	15	4.1
	• Door may be incorrectly balanced - disable soft stop	28	5.17
• Door stops before reaching fully closed position	• Check for correct Close Limit adjustment	15	4.1
• Door will not Safety Reverse	• Check for correct Safety Obstruction Force adjustment settings	16	4.2
	• Battery voltage may be low - check that battery charger is active	21	5.4
• Door requires excessive force to Safety Reverse	• Check for correct Safety Obstruction Force adjustment settings	15	4.1
• Door requires excessive force to Safety Stop	• Check for correct Safety Obstruction Force adjustment settings	15	4.1
• Xtrac will not function from Hand Transmitter	• Check function of XTrac by operating from "Run" button	27	5.13
	• Check function of XTrac with substitute remote control	25	5.9
	• Re-learn remote control code into Xtrac	25	5.9
	• Replace remote control battery	25	5.9
• Hand Transmitter operating range is poor	• Replace Hand Transmitter battery	25	5.9
• Courtesy Lamp will not function	• Replace Courtesy Lamp bulb	24	5.6
	• Battery voltage has dropped below 24V	24	5.6
• Courtesy Lamp triple flashes every 15 sec	• Door balance is incorrect	1	1.3
	• Lubricate garage door springs and hinges	1	1.4
	• Call serviceman if lubricating springs does not correct problem	1	1.6
• LED Indicator glows solid	• XTrac has reached fully closed position	26	5.12
• LED Indicator slow flashes	• XTrac has reached fully open position	26	5.12
• LED Indicator quick flashes	• XTrac is learning new Safety Obstruction Force values	18	4.21
• LED Indicator glows red	• Battery charger is not charging - check battery charger	21	5.4.1
• Buzzer single beeps every 30 sec	• Battery charger is not charging - check battery charger	21	5.4.1
• Buzzer single beeps every 30 sec	• Battery is nearing fully depleted state - check battery charger	21	5.4.2
• Door will not Auto Close	• Check for Safety Beam damage	27	5.14
	• Check for correct Safety Beam alignment	27	5.14
	• Check that Dips 2 & 3 have been selected to the "ON" position	21	5.2
• Will not Safety Reverse when Safety Beams are interrupted	• Check that Dip 2 has been selected to the "ON" position	21	5.2
• XTrac makes "squeaking" sound	• Lubricate inside of Drive Rail with Silicone spray lubricant	30	5.20

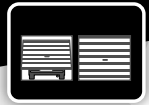

GARAGE DOOR
OPERATORS

Sharecall number **0860-CENTURION**

(Please note that this number is only applicable if dialed from within South Africa)

Please visit **www.centsys.co.za**

for more information on the world-class products manufactured by
Centurion Systems, as well as for details of your nearest agent

Centurion Systems (Pty) Ltd

Tel +27(0)11 699 2400 Fax +27(0)11 704 3412
(Please omit the (0) when dialing from outside South Africa)

Unit 13 Northlands Production Park
Intersection Epsom Avenue and New Market Street
Northriding JOHANNESBURG 2196

PO Box 506 Cramerview 2060 South Africa

sales@centsys.co.za
info@centsys.co.za

South African Branches and Regional Distributors

Bloemfontein	(0)51 430 0870
Cape Town	(0)21 510 0951
Durban	(0)31 701 9583
East London	(0)43 743 4923
Johannesburg Central/West Rand	(0)11 699 2400
Johannesburg East Rand	(0)11 397 6401
Kimberly	(0)53 832 3231
Nelspruit	(0)13 752 8074/5
Port Elizabeth	(0)41 367 1292
Pretoria	(0)12 349 1745
Vereeniging	(0)16 422 5667



DR: 1302.D.01.0001_2 RD:12.04.2011 MAP: 0000.D.01.0008_3 Product code: DOC1302D01

www.centsys.co.za © 2010 Centurion Systems (Pty) Ltd.

E&OE Centurion Systems (Pty) Ltd reserves the right to change any product without prior notice

