

# D-SERIES SMART+ INSTALLATION MANUAL



# Company Profile



1986

1990

1995

1999

Today

**In-house  
R&D  
development  
team**

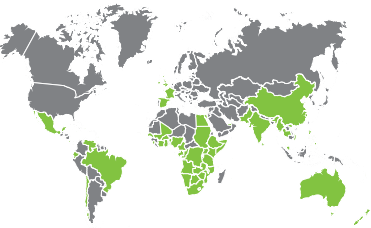
**Manufactures to  
international  
quality standard  
ISO 9001:2015**



**After-sales  
multi-language  
Technical Support**

**100%  
testing of  
products**

**Sales and technical support to Africa, Europe, Asia,  
the Americas, Australia and the Pacific**



**Technical Support  
Operating Times**








**Monday to Friday**  
08h00 to 16h30 GMT+2,

**Saturdays**  
08h00 to 14h00 GMT+2

**Centurion Systems (Pty) Ltd** reserves the right to make changes to the product described in this manual without notice and without obligation to notify any persons of any such revisions or changes. Additionally, **Centurion Systems (Pty) Ltd** makes no representations or warranties with respect to this manual. No part of this document may be copied, stored in a retrieval system or transmitted in any form or by any means electronic, mechanical, optical or photographic, without the express prior written consent of **Centurion Systems (Pty) Ltd**.



	<b>1. INTRODUCTION</b>	<b>PAGE 5</b>
	1.1. Important Safety Information	
	1.2. Safe Disposal of Batteries	
	1.3. Lightning Protection	
	1.4. Theft Protection	
	<b>2. PRODUCT SPECIFICATIONS</b>	<b>PAGE 8</b>
	2.1. Physical Dimensions	
	2.1.1. D3 SMART+, D4 SMART+ and D5-Evo SMART+	
	2.1.2. D6 SMART+	
	2.1.3. D10 SMART+, D10 Turbo SMART+, and D20 SMART+	
	2.2. Technical Specifications (12V Operators)	
	2.2.1. D3 SMART+ and D4 SMART+	
	2.2.2. D5-Evo SMART+	
	2.3. Technical Specifications (24V Operators)	
	2.3.1. D6 SMART+ and D10 SMART+	
	2.3.2. D10 Turbo SMART+ and D20 SMART+	
	2.4. Operations whilst in battery backup (standby) mode	
	2.5. General Technical Specifications	
	<b>3. PRODUCT IDENTIFICATION</b>	<b>PAGE 15</b>
	3.1. D3 SMART+, D4 SMART+ and D5-Evo SMART+	
	3.2. D6 SMART+	
	3.3. D10 SMART+, D10 TURBO SMART+ and D20 SMART+	
	<b>4. REQUIRED TOOLS AND EQUIPMENT</b>	<b>PAGE 18</b>
	<b>5. NEW SITE INSTALLATION PREPARATION</b>	<b>PAGE 19</b>
	5.1. General Considerations for the Installation	
	5.2. End-stops	
	5.3. Guide-rollers and Anti-lift Brackets	
	5.4. Starting and Running Forces	
	5.5. Cabling Requirements	
	<b>6. LUBRICATION</b>	<b>PAGE 22</b>
	<b>7. OPERATOR INSTALLATION</b>	<b>PAGE 23</b>
	7.1. New Site Installations	
	7.1.1. Locating an Initial Reference Point	
	7.1.2. Minimum Clearances - Sides	
	7.1.3. Minimum Clearances - Front	
	7.1.4. Locate the Operator's Position	
	7.1.5. Foundation Plate Installation	
	7.2. Retro-fit Installations (Existing Sites)	
	7.2.1. Retro-fitting if the Existing Foundation Plate is Unusable	
	7.3. Conduit and Cable Length	
	7.4. Preparing for Installation	
	7.4.1. Removing the Charger	
	7.4.2. Removing the Lower Battery Tray	
	7.4.3. Removing the Control Card	
	7.5. Mounting the Gearbox	
	7.6. Routing the Cables	
	7.7. Replacing the Cable Shield	
	7.8. Manual Override	
	7.9. Height Adjustment	
	7.10. Mounitng the Rack	
	7.10.1. Override Sensor	
	7.10.2. Routing the Override Sensor Harness	

	<b>7.11. Re-assembling the SMART+ Operator</b>	
	7.11.1. Override Sensor	
	7.11.2. Routing the Override Sensor Harness	
	7.11.3. Placing the Lower Battery Tray and Charger Back into Position	
	7.11.4. Placing the Control Card Back into Position	
	7.11.5. Reconnecting the Harnesses to the Control Card and Charger	
	<b>7.12. Installing the Origin Sensor</b>	
	<b>8. COMPLETING THE INSTALLATION</b>	<b>PAGE 66</b>
	8.1. Fitting the Battery	
	8.2. Wiring and Connecting the Earth and AC Mains Input	
	8.3. Accessory Installation and Storage	
	<b>9. LOW-VOLTAGE CHARGERS</b>	<b>PAGE 72</b>
	9.1. Isolating Transformer Safety Requirements	
	9.2. Introduction	
	9.3. Low-voltage Charger Technical Specifications	
	9.4. Low-voltage Charger Identification	
	<b>10. WIRING THE CONTROLLER ON DEFAULT SETTINGS</b>	<b>PAGE 74</b>
	10.1. Low-voltage Charger Wiring	
	10.2. Closing Infrared Beam Wiring (i5 Infrared Beams)	
	10.3. Closing Infrared Beam Wiring (Photon Infrared Beams)	
	10.4. Wireless Photon SMART Beams	
	10.5. External Radio Receiver and Loop Detector Wiring	
	10.6. Solar Panel Wiring	
	10.7. G-ULTRA	
	10.8. Earth Spike Installation	
	10.9. 12-24V Siren	
	10.10. GLX900 Gate Lock Wiring	
	10.11. Maglock Wiring	
	10.12. Synchronisation	
	10.13. Commissioning the System	
	10.14. Apply Warning Decal	
	<b>11. GENERAL MAINTENANCE</b>	<b>PAGE 89</b>
	11.1. Gate Maintenance	
	11.2. SMART+ Operator Maintenance	
	<b>12. PRODUCT ANCILLARIES</b>	<b>PAGE 90</b>
	<b>13. INSTALLATION HANDOVER CHECKLIST</b>	<b>PAGE 91</b>
	<b>14. WARRANTY INFORMATION</b>	<b>PAGE 93</b>



Images in this Installation Manual may vary depending on the **SMART+ Operator** chosen for installation.

#### Icons used in this manual



This icon indicates tips and other information that could be useful during the installation.



This icon denotes variations and other aspects that should be considered during installation.



**This icon indicates warning, caution or attention! Please take special note of critical aspects that MUST be adhered to in order to prevent injury.**



This icon indicates a clickable hyperlink.

# 1. Introduction

## FAST TRACK HYPERLINKS

### 1. INTRODUCTION

#### 1.1. Important Safety Information

#### 1.2. Safe Disposal of Batteries

#### 1.3. Lightning Protection

#### 1.4. Theft Protection

The **D-SERIES SMART+** Operators cater for residential through to industrial sites, designed to open and close sliding gates weighing between 300kg to 2000kg. Custom-designed gearboxes moulded from robust engineering materials, coupled to powerful DC motors, provides fast and reliable automation for entrances from homes to large industrial sites.

The system operates off a 12V 7Ah battery(ies) housed inside the operator using a switch-mode charger to maintain the batteries in a fully-charged state. The battery(ies) provide critical power failure protection.

A non-contact Hall Effect Sensor was selected to ensure reliability and positional accuracy. The Hall Effect Sensor is highly resistant to dust, oil, dirt or insect ingress, therefore ensuring that the **SMART+** Operator opens and closes gates reliably and accurately.

#### Advanced features of the SMART+ logic controllers include:

- Interactive graphic user interface via a Smartphone application
- Automated setup of gate end-points (limits)
- Independently-adjustable motor speed in both opening and closing directions
- Fail-safe collision detection and auto-reverse (adjustable sensitivity)
- Smooth, adjustable start/stop (ramp-up/ramp-down)
- Multiple operational modes
- Selectable, adjustable Autoclose
- Pedestrian (partial) opening
- Positive Close Mode
- Independent safety inputs for opening and closing beams
- Automatic beam test for both opening and closing beams<sup>1</sup>
- Advanced lightning/surge protection
- Onboard NOVA code-hopping radio receiver with full channel-mapping capability

1. Not applicable to the **D3 SMART+** Operator

### 1.1. Important Safety Information



#### ATTENTION!

To ensure the safety of people and possessions, it is important that you read all of the following instructions.

**Incorrect installation or incorrect use of the product could cause serious harm to people.**

**The installer is the last person on the site who can ensure that the operator is safely installed and that the whole system can be operated safely.**

### Warnings for the Installer

**CAREFULLY READ AND FOLLOW ALL INSTRUCTIONS** before installing the product.

This product is an automated mechanical and electrical system and must be installed, adjusted, and serviced by a competent person, as defined in applicable South African occupational health and safety legislation. Electrical connections must comply with SANS 10142 1 and the Electrical Installation Regulations. Installation requirements are aligned with applicable SANS IEC 60335 safety standards for automated doors and gates. Failure to comply may result in injury, death, property damage, and voiding of warranty.

- All installation, repair, and service work to this product must be carried out by a suitably qualified person
- This appliance is not intended for use by persons (including children) with reduced physical, sensory or mental capabilities, or lack of experience and knowledge, unless they have been given supervision or instruction concerning use of the appliance by a person responsible for their safety
- Do not activate your gate unless it is in view and you can determine that its area of travel is clear of people, pets, or other obstructions
- **NO ONE MAY CROSS THE PATH OF A MOVING GATE** — always keep people and objects away from the gate and its area of travel
- **NEVER LET CHILDREN OPERATE OR PLAY WITH THE GATE CONTROLS**
- Secure all easily-accessed gate opener controls in order to prevent unauthorised use of the gate
- Do not in any way modify the components of the automated system
- Do not install the equipment in an explosive atmosphere: the presence of flammable gases or fumes is a serious danger to safety
- Before attempting any work on the system, turn off electrical power to the operator and disconnect the batteries
- The Mains power supply of the automated system must be fitted with an all-pole switch with contact opening distance of 3mm or greater; use of a 5A hydraulic breaker with all-pole circuit break is recommended
- Make sure that an earth leakage circuit breaker with a threshold of 30mA is fitted upstream of the system
- Never short-circuit the Battery and do not attempt to recharge the batteries with power supply units other than that supplied with the product, or manufactured by **Centurion Systems (Pty) Ltd**
- Make sure that the earthing system is correctly constructed and that all metal parts of the system are suitably earthed
- Safety devices must be fitted to the installation to guard against mechanical movement risks such as crushing, dragging and shearing
- Always fit the warning signs visibly to the inside and outside of the gate
- The installer must explain and demonstrate the manual operation of the gate in case of an emergency and must hand over the User Guide/Warnings to the user
- The installer must explain these safety instructions to all persons authorised to use this gate, and be sure that they understand the hazards associated with automated gates
- Do not leave packing materials (plastic, polystyrene, etc.) within reach of children as such materials are potential sources of danger
- Dispose of all waste products like packing materials, worn-out batteries, etc., according to local regulations
- Always check the obstruction detection system, and safety devices for correct operation
- Neither **Centurion Systems (Pty) Ltd**, nor its subsidiaries, accepts any liability caused by improper use of the product, or for use other than that for which the automated system was intended
- This product was designed and built strictly for the use indicated in this documentation; any other use, not expressly indicated here, could compromise the service life/operation of the product and/or be a source of danger
- Everything not expressly specified in these instructions is not permitted

## 1.2. Safe Disposal of Batteries



### ATTENTION!

- Do not incinerate
- Do not short the Battery terminals
- Do not charge in a gas tight container
- Do not open
- Recharge after use
- Flush with water at once if contact is made with electrolyte (acid)



### 1.3. Lightning Protection

The electronic controller utilises the same proven surge protection philosophy that is used in all our products. While this does not guarantee that the unit will not be damaged in the event of a lightning strike or power surge, it greatly reduces the likelihood of such damage occurring. The earth return for the surge protection is provided via the mains power supply earth and/or earth spike located next to the operator.




**In order to ensure that the surge protection is effective, it is essential that the unit is properly earthed.**

### 1.4. Theft Protection

While care has been taken in the design of the **D-SERIES SMART+** Operators to prevent unauthorised removal (theft) of the unit, an optional steel theft-deterrent cage is also available for added peace of mind.



If a theft-deterrent cage is required, be sure to leave enough clearance from pillars, etc. (Section 7.1.2. - "Minimum Clearances" ).



## 2. Product Specifications

### FAST TRACK HYPERLINKS

#### 2.1. Physical Dimensions

2.1.1. [D3 SMART+, D4 SMART+ and D5-Evo SMART+](#)

2.1.2. [D6 SMART+](#)

2.1.3. [D10 SMART+, D10 Turbo SMART+ and D20 SMART+](#) 

#### 2.2. Technical Specifications (12V Operators)

2.2.1. [D3 SMART+ and D4 SMART+](#) 

2.2.2. [D5-Evo SMART+](#) 

#### 2.3. Technical Specifications (24V Operators)

2.3.1. [D6 SMART+ and D10 SMART+](#) 

2.3.2. [D10 Turbo SMART+ and D20 SMART+](#) 

2.4. [Operations whilst in Battery Backup \(Standby\) Mode](#) 

2.5. [General Technical Specifications](#) 

### 2.1. Physical Dimensions

2.1.1. [D3 SMART+, D4 SMART+ and D5-Evo SMART+](#)

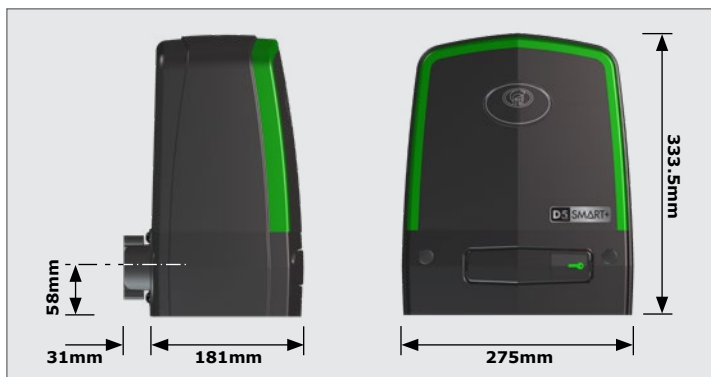


FIGURE 1. D3 SMART+, D4 SMART AND D5-EVO SMART+ PHYSICAL DIMENSIONS

2.1.2. [D6 SMART+](#)

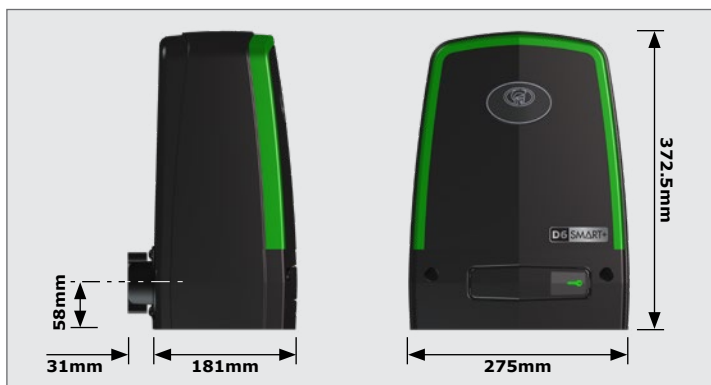


FIGURE 2. D6 SMART+ PHYSICAL DIMENSIONS

## 2.1.3. D10 SMART+, D10 TURBO SMART+ and D20 SMART+



FIGURE 3. D10 SMART+, D10 TURBO SMART+ AND D20 SMART+ PHYSICAL DIMENSIONS

## 2.2. Technical Specifications (12V Operators)

## 2.2.1. D3 SMART+ and D4 SMART+

	D3 SMART+		D4 SMART+	
Input voltage <sup>1,2</sup>	100V - 240V AC 50/60Hz			
Current consumption (mains)	320mA peak			
Battery Charger Current Output	1.8A @ 14.3V +/- 5% (28W)			
Maximum number of Operations per day	20 <sup>3,6</sup>		75 <sup>3,6</sup>	
Duty Cycle - Mains Present <sup>2,3</sup>	25%			
Motor Power Supply	Battery-driven (Standard Capacity - 1x12V <sup>5</sup> 7Ah)			
Current Consumption (Motor at Rated load)	11A		15A	
<b>Input/Output Sink Currents (Max. Accessory Current Draw)</b>				
I/O 1	na		100mA (12V)	
I/O 2	na		100mA (12V)	
<b>Fuse Protection</b>	<b>Type</b>	<b>Rating</b>	<b>Type</b>	<b>Rating</b>
Main Control Card	Serviceable	35A Mini ATO	Serviceable	35A Mini ATO
Aux. Supply	Resettable Fuse	12V 300mA MAX	Resettable Fuse	12V 300mA MAX
Charger (Mains Supply)	Non-serviceable	3A slow-blow	Non-serviceable	3A slow-blow
Motor Push Force - Starting	18kgf (Maximum)		18kgf	
Motor Push Force - Rated	12kgf (Maximum)		12kgf	
Gate Mass - Maximum	300kg		450kg	
Gate Length - Maximum	10m <sup>8</sup>		10m <sup>8</sup>	
Gate Speed (Varies with load) <sup>4</sup>	<b>Max:</b> Up to 24m/min <b>Rated:</b> Up to 21m/min		<b>Max:</b> Up to 28m/min <b>Rated:</b> Up to 24m/min	
Wireless Communication	BLE and Wi-Fi (2.4Ghz)			
Receiver Code Storage Capacity	1500 Remotes			

TABLE 1



This equipment is compliant with the radiated emissions requirements of EN 55032 / CISPR 32 for Class B devices, which intends to offer adequate protection to broadcast services within the residential environment.

## 2.2.2. D5-EVO SMART+

D5-Evo SMART+		
Input voltage <sup>1,2</sup>	100V - 240V AC 50/60Hz	
Current consumption (mains)	320mA peak	
Battery Charger Current Output	1.8A @ 14.3V +/- 5% (28W)	
Maximum number of Operations per day	150 <sup>3,6</sup>	
Duty Cycle - Mains Present <sup>2,3</sup>	50%	
Motor Power Supply	Battery-driven (Standard Capacity - 1x12V <sup>5</sup> 7Ah)	
Current Consumption (Motor at Rated load)	15A	
<b>Input/Output Sink Currents (Max. Accessory Current Draw)</b>		
I/O 4 and I/O 5	100mA (12V)	
O6	3A (12V) 10sec Pulse	
<b>Fuse Protection</b>	<b>Type</b>	<b>Rating</b>
Main Control Card	Serviceable	35A Mini ATO
Aux. Supply	Resettable Fuse	12V 3A (10sec Pulse)
Charger (Mains Supply)	Non-serviceable	3A slow-blow
Motor Push Force - Starting	30kgf	
Motor Push Force - Rated	17kgf	
Gate Mass - Maximum	500kg	
Gate Length - Maximum	20m <sup>8</sup>	
Gate Speed (Varies with load) <sup>4</sup>	<b>Maximum:</b> Up to 24m/min <b>Rated:</b> Up to 19m/min	
Wireless Communication	BLE and Wi-Fi (2.4Ghz)	
Receiver Code Storage Capacity	1500 Remotes	

TABLE 2



This equipment is compliant with the radiated emissions requirements of EN 55032 / CISPR 32 for Class B devices, which intends to offer adequate protection to broadcast services within the residential environment.

## 2.3. Technical Specifications (24V Operators)

### 2.3.1. D6 SMART+ and D10 SMART+

	D6 SMART+		D10 SMART+	
<b>Input Voltage<sup>1</sup></b>	100V - 240V AC 50/60Hz			
<b>Current Consumption (Mains)</b>	430mA		590mA	
<b>Battery Charger Current Output</b>	1.3A @ 27.6V +/- 5% (38W)		1.8A @ 27.6V +/- 5% (52W)	
<b>Maximum number of Operations per day</b>	150 <sup>3,6</sup>		750 <sup>3,6</sup>	
<b>Duty Cycle - Mains Present<sup>2,3</sup></b>	50%		45%	
<b>Motor Power Supply</b>	Battery-driven (Standard Capacity - 2x12V <sup>5</sup> 7Ah)			
<b>Current Consumption (Motor at Rated Load)</b>	13A		8A	
<b>Input/Output Sink Currents (Max. Accessory Current Draw)</b>				
I/O 1-4	100mA (24V)			
I/O 5 and 6	3A (24V) 10sec Pulse			
<b>Fuse Protection</b>	<b>Type</b>	<b>Rating</b>	<b>Type</b>	<b>Rating</b>
Main Control Card	Serviceable	35A Mini ATO	Serviceable	35A Mini ATO
Aux. Supply	Resettable Fuse	24V 3A	Resettable Fuse	24V 3A (10sec Pulse)
Charger (Mains Supply)	Non-serviceable	3A slow-blow	Non-serviceable	3A slow-blow
<b>Motor Push Force - Starting</b>	30kgf		40kgf	
<b>Motor Push Force - Rated</b>	17kgf (Maximum)		30kgf	
<b>Gate Mass - Maximum</b>	600kg		1000kg	
<b>Gate Length - Maximum</b>	100m <sup>8</sup>		50m <sup>8</sup>	
<b>Gate Speed (Varies with Load)<sup>4</sup></b>	<b>Max:</b> Up to 35m/min <b>Rated:</b> Up to 30m/min		<b>Max:</b> Up to 26m/min <b>Rated:</b> Up to 21m/min	
<b>Wireless Communication</b>	BLE and Wi-Fi (2.4Ghz)			
<b>Receiver Code Storage Capacity</b>	1500 Remotes			

TABLE 3



This equipment is compliant with Class A of CISPR 32 / EN 55032. In a residential environment, this equipment may cause interference.

## 2.3.2. D10 TURBO SMART+ and D20 SMART+

	D10 TURBO SMART+	D20 SMART+
<b>Input Voltage<sup>1</sup></b>	100V - 240V AC 50/60Hz	
<b>Current Consumption (Mains)</b>	590mA	
<b>Battery Charger Current Output</b>	1.8A @ 27.6V +/- 5% (52W)	
<b>Maximum number of operations per day</b>	750 <sup>3,6</sup>	
<b>Duty cycle - Mains present<sup>2,3</sup></b>	25%	45%
<b>Motor power supply</b>	Battery-driven (Standard Capacity - 2x12V <sup>5</sup> 7Ah)	
<b>Current consumption (motor at rated load)</b>	10A	9A
<b>Input / Output sink currents (Max. accessory current draw)</b>		
I/O 1-4	100mA (12/24V)	
I/O 5 and 6	3A (12/24V) 10sec Pulse	
<b>Fuse Protection</b>	<b>Type</b>	<b>Rating</b>
Main Control Card	Serviceable	35A Mini ATO
Aux. Supply	Resettable Fuse	24V 3A (10sec Pulse)
Charger (Mains Supply)	Non-serviceable	3A slow-blow
<b>Motor push force - starting</b>	24kgf	52kgf
<b>Motor push force - rated</b>	18kgf (maximum)	39kgf
<b>Gate mass - maximum</b>	250kg	2000kg
<b>Gate length - maximum</b>	100m <sup>8</sup>	50m <sup>8</sup>
<b>Gate speed (varies with load)<sup>4</sup></b>	<b>Max:</b> Up to 43m/min <b>Rated:</b> Up to 34m/min	<b>Max:</b> Up to 18m/min <b>Rated:</b> Up to 16m/min
<b>Wireless Communication</b>	BLE and Wi-Fi (2.4Ghz)	
<b>Receiver code storage capacity</b>	1500 Remotes	

TABLE 4



**This equipment is compliant with Class A of CISPR 32 / EN 55032. In a residential environment, this equipment may cause interference.**

1. Can operate off a solar supply, consult your local dealer for assistance.
2. Based on 25°C ambient temperature and unit not in direct sunlight.
3. Based on a motor push force of less than 50% of rated (Starting and Running forces).
4. Gate opening and closing speeds can be configured to run slower depending on the requirements of individual installations.
5. Can increase battery capacity for longer standby times.
6. Based on 4m gate, excluding all accessories.
7. Multiple buttons per remote can be used.
8. Dependent on push force.

 [BACK TO 2.2. TECHNICAL SPECIFICATIONS \(12V OPERATORS\)](#)

 [BACK TO 2.3. TECHNICAL SPECIFICATIONS \(24V OPERATORS\)](#)

## 2.4. Operations whilst in battery backup (standby) mode

Operations in standby (7.2Ah Battery)	D3 SMART+ Operating Mode			
	Up to 24m/min 7kgf		Up to 21m/min 12kgf	
Half day <sup>1,2,3</sup>	90		80	
Full day <sup>1,2,3</sup>	70		65	

Operations in standby (7.2Ah Battery)	D4 SMART+ Operating Mode			
	Up to 24m/min 7kgf		Up to 24m/min 12kgf	
Half day <sup>1,2,3</sup>	90		80	
Full day <sup>1,2,3</sup>	70		65	

Operations in standby (7.2Ah Battery)	D5-Evo SMART+ Operating Mode			
	Up to 24m/min 7kgf		Up to 18m/min 17kgf	
Half day <sup>1,2,3</sup>	90		44	
Full day <sup>1,2,3</sup>	70		35	

Operations in standby (7.2Ah Batteries)	D6 SMART+ Operating Modes			
	Power Saving 15m/min 7kgf	Power Saving 15m/min 17kgf	Normal 30m/min 7kgf	Normal 30m/min 17kgf
Half day <sup>1,2,3</sup>	209	96	102	70
Full day <sup>1,2,3</sup>	183	87	79	59

Operations in standby (7Ah - 28W Batteries)	D6 SMART+ Operating Modes			
	Power Saving 15m/min 7kgf	Power Saving 15m/min 17kgf	Normal 30m/min 7kgf	Normal 30m/min 17kgf
Half day <sup>1,2,3</sup>	197	87	70	42
Full day <sup>1,2,3</sup>	170	75	45	30

Operations in standby (7.2Ah Batteries)	D10 SMART+ Operating Modes			
	Power Saving 15m/min 15kgf		Normal 26m/min 15kgf	
Half day <sup>1,2,3</sup>	118		63	
Full day <sup>1,2,3</sup>	93		50	

Operations in standby (7.2Ah Batteries)	D10 TURBO SMART+ Operating Modes			
	Power Saving 15m/min 9kgf		Normal 45m/min 9kgf	
Half day <sup>1,2,3</sup>	189		130	
Full day <sup>1,2,3</sup>	150		104	

Operations in standby (7.2Ah Batteries)	D20 SMART+ Operating Modes			
	Power Saving 15m/min 20kgf		Normal 18m/min 20kgf	
Half day <sup>1,2,3</sup>	101		55	
Full day <sup>1,2,3</sup>	80		45	

TABLE 5

## 2.5. General Specifications

Manual Override	Lockable with key release
Collision Sensing	Electronic
Operating temperature range	-15°C to +50°C
Onboard receiver type	Code-hopping multichannel receiver with selective add and delete
Receiver frequency	433.92MHz
Degree of protection	<b>D3 SMART+, D4 SMART+ D5-Evo SMART+ and D6 SMART+:</b> IP55 <b>D10 SMART+, D10 TURBO SMART+ and D20 SMART+:</b> IP54

TABLE 6

INTRO

SPECS

PARTS

TOOLS

NEW SITES

OIL

INSTALL

FINISH

LOW-VOLT CHARGER

WIRING

SERVICE



EXTRAS

HAND OVER

WARRANTY

## 3. Product Identification

### FAST TRACK HYPERLINKS

- 3.1. **D3 SMART+, D4 SMART+ and D5-Evo SMART+**
- 3.2. **D6 SMART+** 
- 3.3. **D10 SMART+, D10 TURBO SMART+ and D20 SMART+** 

#### 3.1. D3 SMART+, D4 SMART+ and D5-Evo SMART+

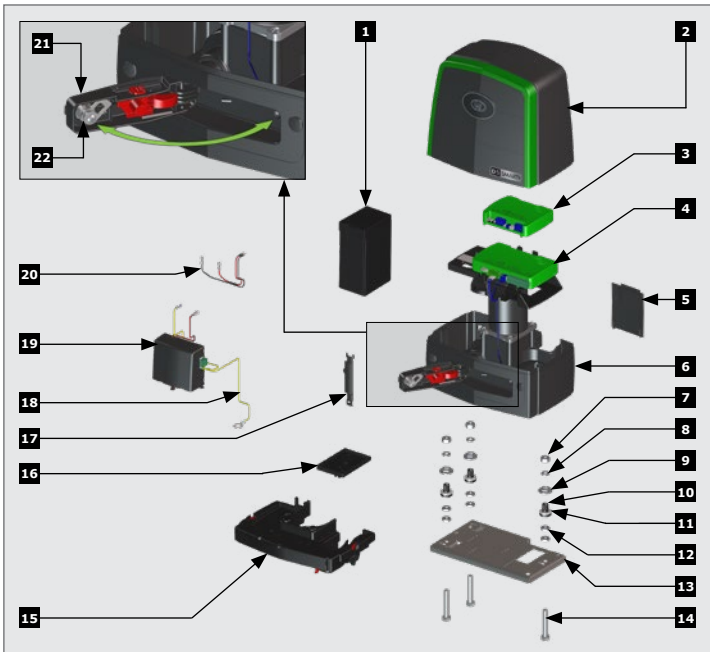


FIGURE 4. D3 SMART+, D4 SMART+ AND D5-EVO SMART+ PRODUCT IDENTIFICATION

- |                                      |                                   |
|--------------------------------------|-----------------------------------|
| 1. 12V Battery <sup>1</sup>          | 12. M10 Half-Nut                  |
| 2. <b>D3/D4/D5-Evo SMART+</b> Cover  | 13. Foundation Plate <sup>2</sup> |
| 3. <b>D3/D4 SMART+</b> Control Card  | 14. Mounting Bolt <sup>2</sup>    |
| 4. <b>D5-Evo SMART+</b> Control Card | 15. Lower Battery Tray            |
| 5. Cable Shield                      | 16. Cable Cover                   |
| 6. Gearbox                           | 17. Cable Trunking                |
| 7. M10 Nut (17mm Socket)             | 18. Earth Harness                 |
| 8. Spring Washer                     | 19. Switch-Mode 1.8A charger      |
| 9. Top Height Adjuster (19mm Socket) | 20. Battery Harness               |
| 10. Bottom Height Adjuster           | 21. Release Handle                |
| 11. Heavy Duty M12 Washer            | 22. Camlock                       |

1. Batteries are not supplied with these **SMART+ Operators**. These **SMART+ Operators** supports both 7Ah and 7.2Ah variants.
2. The Foundation Plate is not supplied with these **SMART+ Operators**. Contact Centurion Systems (Pty) Ltd for more information.

## 3.2. D6 SMART+

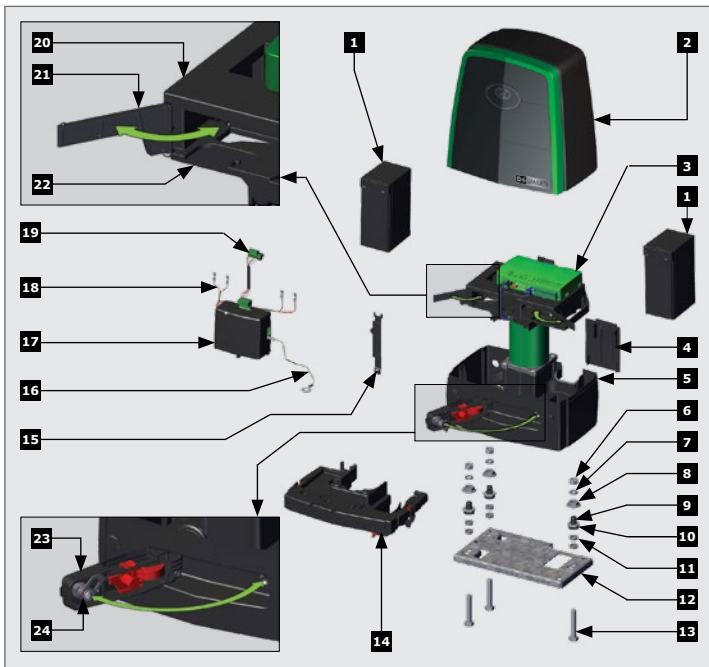


FIGURE 5. PRODUCT IDENTIFICATION

- |                                      |                              |
|--------------------------------------|------------------------------|
| 1. 12V Batteries <sup>1</sup>        | 14. Lower Battery Tray       |
| 2. <b>D6 SMART+</b> Cover            | 15. Cable Trunking           |
| 3. DX Control Card                   | 16. Earth Harness            |
| 4. Cable Shield                      | 17. Switch-Mode 1.3A charger |
| 5. Gearbox                           | 18. Battery Harness          |
| 6. M10 Nut (17mm Socket)             | 19. Power Supply Harness     |
| 7. Spring Washer                     | 20. Accessory Tray           |
| 8. Top Height Adjuster (19mm Socket) | 21. Accessory Retaining Door |
| 9. Bottom Height Adjuster            | 22. Top Battery Stabiliser   |
| 10. Heavy Duty M12 Washer            | 23. Release Handle           |
| 11. M10 Half-Nut                     | 24. Camlock                  |
| 12. Foundation Plate <sup>2</sup>    |                              |
| 13. Mounting Bolt <sup>2</sup>       |                              |

- Batteries are not supplied with this **SMART+ Operator**. This **SMART+ Operator** supports both 7Ah and 7.2Ah variants.
- The Foundation Plate is not supplied with this **SMART+ Operator**. Contact Centurion Systems (Pty) Ltd for more information.

## 3.3. D10 SMART+, D10 Turbo SMART+, and D20 SMART+

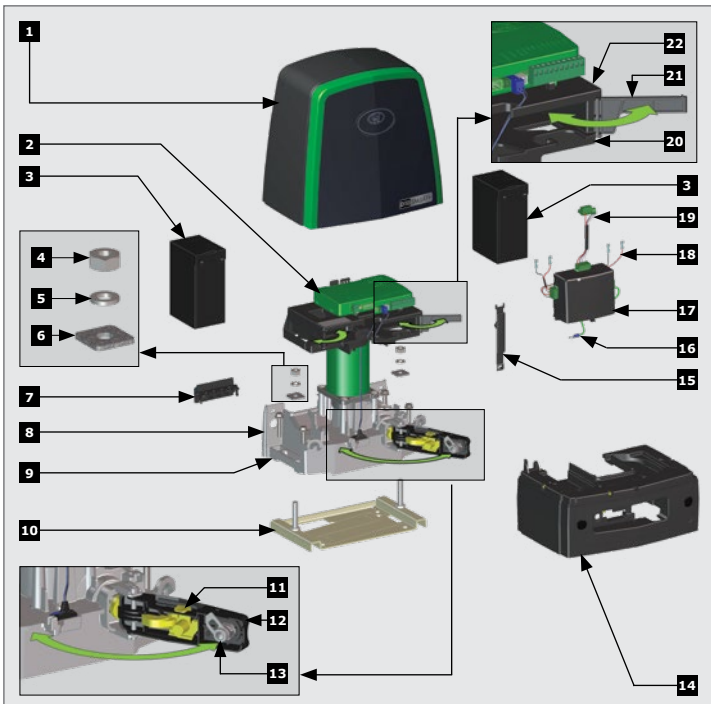


FIGURE 6. D10 SMART+, D10 TURBO SMART+, &amp; D20 SMART+ PRODUCT IDENTIFICATION

- |                                     |                                    |
|-------------------------------------|------------------------------------|
| 1. <b>SMART+ Operator</b> Cover     | 12. Release Handle                 |
| 2. <b>Dx</b> Control Card           | 13. Camlock                        |
| 3. 7.2Ah 12V Batteries <sup>1</sup> | 14. Gearbox Trim                   |
| 4. M10 Nut                          | 15. Cable Trunking                 |
| 5. Spring Washer                    | 16. Earth Harness                  |
| 6. Gearbox Mounting Washer          | 17. Switch-mode Charger 27.4V 1.8A |
| 7. Cable Shield                     | 18. Battery Harness                |
| 8. Hex Height Adjustment Bolt (x4)  | 19. Power Supply Harness           |
| 9. Die-cast Aluminium Gearbox       | 20. Top Battery Stabiliser         |
| 10. Foundation Plate <sup>2</sup>   | 21. Accessory Retaining Door       |
| 11. Override Cam                    | 22. Accessory Tray                 |

- Batteries are not supplied with these **SMART+ Operators**. These **SMART+ Operators** supports both 7Ah and 7.2Ah variants.
- The Foundation Plate is not supplied with these **SMART+ Operators**. Contact Centurion Systems (Pty) Ltd for more information.

## 4. Required Tools and Equipment

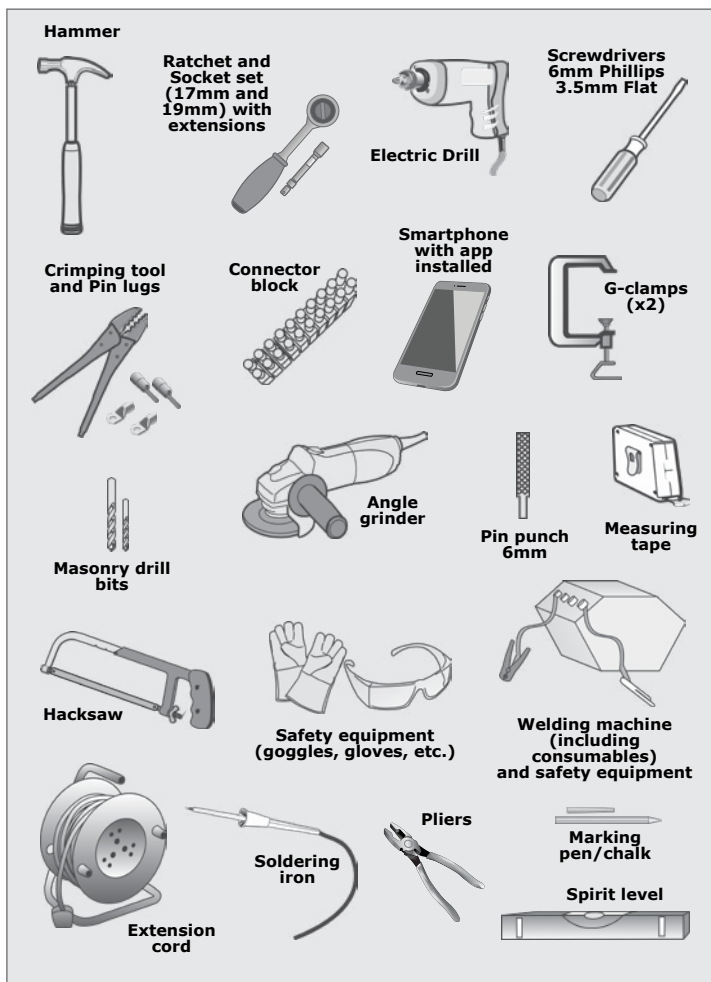




FIGURE 7. REQUIRED TOOLS AND EQUIPMENT

## 5. New Site Installation Preparation

### FAST TRACK HYPERLINKS

- 5.1. [General Considerations for the Installation](#)
- 5.2. [End-stops](#)
- 5.3. [Guide-rollers and Anti-lift Brackets](#) 
- 5.4. [Starting and Running Forces](#) 
- 5.5. [Cabling Requirements](#) 

### 5.1. General Considerations for the Installation

Always recommend the fitment of additional safety equipment such as safety edges and safety beams, for additional protection against entrapment or other mechanical risks.

Check that no pipes or electrical cables are in the way of the intended installation.

Check that enough space is available for the gate operator, specifically for the release handle (See Section 7.1.2. - "Minimum Clearances" ) .

Check for loose, sandy soil if installing a foundation, as the soil condition may require a larger foundation.

Never fit the operator on the outside of the gate, where the public have access to it.

#### Install the gate operator only if:

- It will not pose a hazard to the public
- There is sufficient clearance to a roadway and/or public thoroughfares
- The installation meets all municipal and/or local authority requirements once completed
- The gate mass and application are within the operator specifications
- The gate is in good working order, meaning:
  - that it opens and closes freely;
  - does not move on its own if left in any position;
  - it can be installed to have sufficient clearance between moving parts when opening and closing to reduce the risk of personal injury and entrapment;
- Pushbuttons or key-switches, when required, can be positioned so that the gate is in line-of-sight of the user

### 5.2. End-Stops

Fit opening and closing end-stops capable of stopping the gate at rated speed. Refer to the specifications at the beginning of this manual for the operating speed.

**Make  $H1 > H2$  to ensure gate will not jump over the endstop.**

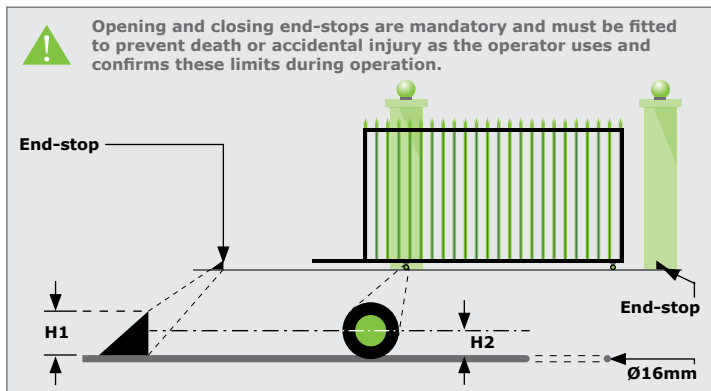


FIGURE 8. FITTING END-STOPS

### 5.3. Guide-rollers and Anti-lift Brackets

Guide-rollers must be installed to ensure that the gate is held vertical. For improved safety, fit additional support posts to prevent the gate from falling over should the guide-rollers fail.

To prevent unauthorised access, fit anti-lift brackets as shown. The gap between the anti-lift bracket and the gate must be less than 5mm.



Ensure that the gate cannot be lifted off the motor pinion with the anti-lift bracket fitted.

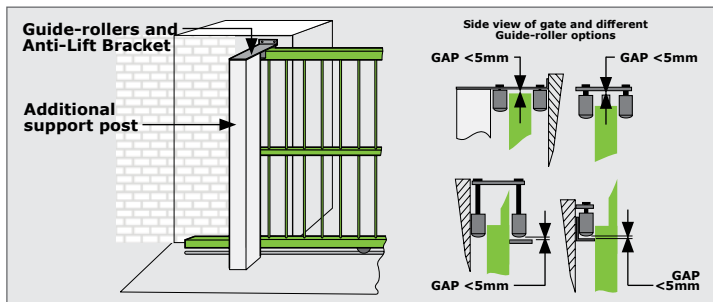


FIGURE 9. FITTING GUIDE-ROLLERS

### 5.4. Starting and Running Forces

Test the starting force of the gate as per the diagram. Use a pull scale in **both directions** to determine the maximum amount of pull force required to set the gate in motion.

Determine the running force of the gate by continuing to pull on the scale with just sufficient force to keep it running.

Read and note the maximum value in kgf (kilogram-force) shown on the scale.

Where possible, determine the gate mass.

Our warranty will be void if the pull force and / or gate mass exceeds the below operator specifications:

#### D3 SMART+

- Starting force - 18kgf - Maximum over the full length of gate travel
- Running (rated) force - 12kgf -Maximum over the full length of gate travel
- Maximum gate mass - 300kg

#### D4 SMART+

- Starting force - 18kgf - Maximum over the full length of gate travel
- Running (rated) force - 12kgf -Maximum over the full length of gate travel
- Maximum gate mass - 450kg

#### D5-Evo SMART+

- Starting force - 30kgf - Maximum over the full length of gate travel
- Running (rated) force - 17kgf - Maximum over the full length of gate travel
- Maximum gate mass - 500kg

#### D6 SMART+

- Starting force - 30kgf - Maximum over the full length of gate travel
- Running (rated) force - 17kgf - Maximum over the full length of gate travel
- Maximum gate mass - 600kg

#### D10 SMART+

- Starting force - 40kgf - Maximum over the full length of gate travel
- Running (rated) force - 30kgf - Maximum over the full length of gate travel
- Maximum gate mass - 1000kg

#### D10 Turbo SMART+

- Starting force - 24kgf - Maximum over the full length of gate travel
- Running (rated) force - 18kgf - Maximum over the full length of gate travel
- Maximum gate mass - 250kg

**D20 SMART+**

- Starting force - 52kgf - Maximum over the full length of gate travel
- Running (rated) force - 39kgf - Maximum over the full length of gate travel
- Maximum gate mass - 2000kg

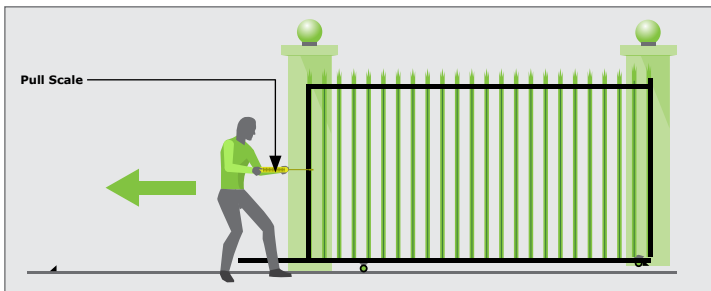


FIGURE 10. STARTING AND RUNNING FORCES

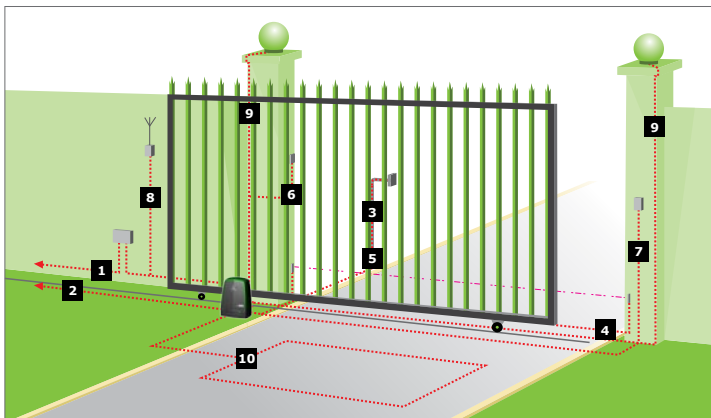
**5.5. Cabling Requirements**

FIGURE 11. CABLING REQUIREMENTS

1. **MAINS SUPPLY CABLE:** 90V - 240V AC mains cable via double-pole mains isolator-switch (3 core L.N.E. 1.5mm<sup>2</sup> SWA)<sup>1,2</sup>
2. Optional **intercom** cable from motor to dwelling (n1 + 6 core<sup>3</sup> 0.22mm<sup>2</sup> multi-strand shielded cable)
3. Optional **intercom** cable from motor to entry panel (n2 0.22mm<sup>2</sup> multi-strand shielded cable)
4. Optional but recommended **infrared safety beams** (3 core 0.22mm<sup>2</sup> multi-stranded)<sup>4</sup>
5. Optional **access control device** (3 core 0.22mm<sup>2</sup> multi-stranded)
6. Optional **pedestrian key-switch** (2 core 0.22mm<sup>2</sup> multi-stranded) OR
7. Optional **keypad** (3 core 0.22mm<sup>2</sup> multi-stranded)<sup>4</sup>
8. Optional **external radio receiver** (3 core 0.22mm<sup>2</sup> multi-stranded)<sup>5</sup>
9. Optional **pillar lights** (3 core LNE SWA, size according to power requirements)<sup>6,7</sup>
10. Optional **ground loop for free-exit** (1 core 0.5mm<sup>2</sup> multi-stranded – silicone coated)<sup>8</sup>

n1 means the number of cores required by an intercom

n2 means the number of cores required by an intercom

1. Possibly increase cable thickness if pillar lights are installed.

2. Type of cable must adhere to municipal bylaws but typically SWA (steel wire armoured) cable is recommended.

The armouring provides excellent screening, which gives better protection against lightning – earth one end of the screening).

3. Allows for all features such as pedestrian opening, status LED, etc., to be operated from the intercom handset inside the dwelling.

Number of cores and type of cable could vary depending on brand of access control system being used.

4. Wireless accessories are available. Please refer to [www.centsys.com](http://www.centsys.com) for further information.

5. For optimum range, an external receiver can be mounted on the wall.

6. Requires an external relay

7. Not applicable for **D3 SMART+**

8. Consult manufacturer of loop detector for specific details.

## 6. Lubrication

The internal gerset of the **SMART+** Operators is lubricated by means of an oil bath.



**The SMART+ Operators are supplied with oil in its Gearbox and do not require routine oil changes.**

INTRO

SPECS

PARTS

TOOLS

NEW  
SITES

OIL

INSTALL

FINISH

LOW-VOLT  
CHARGER

WIRING

SERVICE

EXTRAS

HAND  
OVER

WARRANTY

## 7. Operator Installation

### FAST TRACK HYPERLINKS

#### 7.1. New Site Installations

- 7.1.1. [Locating an Initial Reference Point](#)
- 7.1.2. [Minimum Clearances - Sides](#)
- 7.1.3. [Minimum Clearances - Front](#)
- 7.1.3.1. [Front - D3 SMART+, D4 SMART+, D5-Evo SMART+ and D6 SMART+](#)
- 7.1.3.2. [Front - D10 SMART+, D10 Turbo SMART+ and D20 SMART+](#)
- 7.1.4. [Locate the Operator's Position](#)
- 7.1.5. [Foundation Plate Installation](#)

#### 7.2. Retro-fit Installations (Existing Sites)

- 7.2.1. [Retro-fitting if the Existing Foundation Plate is Unusable](#)

#### 7.3. Conduit and Cable Length

#### 7.4. Preparing for Installation

- 7.4.1. [Removing the Charger](#)
- 7.4.2. [Removing the Lower Battery Tray / Gearbox Trim](#)
- 7.4.3. [Removing the Control Card](#)

#### 7.5. Mounting the Gearbox

- 7.5.1. [D3 SMART+, D4 SMART+, D5-Evo SMART+ and D6 SMART+](#)
- 7.5.2. [D10 SMART+, D10 Turbo SMART+ and D20 SMART+](#)

#### 7.6. Routing the Cables

- 7.6.1. [D3 SMART+, D4 SMART+, D5-Evo SMART+ and D6 SMART+](#)
- 7.6.2. [D10 SMART+, D10 Turbo SMART+ and D20 SMART+](#)

#### 7.7. Replacing the Cable Shields

#### 7.8. Manual Override

#### 7.9. Height Adjustment

#### 7.10. Mounting the Rack

- 7.10.1. [Fitting Different Types of Rack to the Gate](#)
- 7.10.2. [Finalising the Height Adjustment](#)

#### 7.11. Re-assembling the SMART+ OPERATOR

- 7.11.1. [D3 SMART+, D4 SMART+, D5-Evo SMART+ and D6 SMART+](#)
- 7.11.2. [D10 SMART+, D10 Turbo SMART+ and D20 SMART+](#)
- 7.11.3. [Placing the Charger Back into Position](#)
- 7.11.4. [Placing the Control Card Back into Position](#)
- 7.11.5. [Reconnecting the Harnesses to the Control Card and Charger](#)

#### 7.12. Installing the Origin Sensor and Marker

### 7.1. New Site Installations



When installing the **SMART+ Operator**, it is important to take note of the information found in Section 7.1.1. and Section 7.1.2. when determining the position of the Foundation Plate, and the height of the **SMART+ Operator** in relation to the gate that is to be automated.

#### 7.1.1. Locating an Initial Reference Point

Firstly, it is necessary to establish a reference point. To do this, manually open and close the gate so that it moves past a stationary point (i.e. a vertical spike), and determine which part of the gate (including its wheels) protrudes the furthest towards where the **SMART+ Operator** will be installed. Refer to the examples shown below.



Once the point which protrudes the furthest has been found, this will be the reference point to be used when finding the optimum position for the **SMART+ Operator**



Check for wheels, palisade, uprights, etc. that could potentially collide with the Pinion.

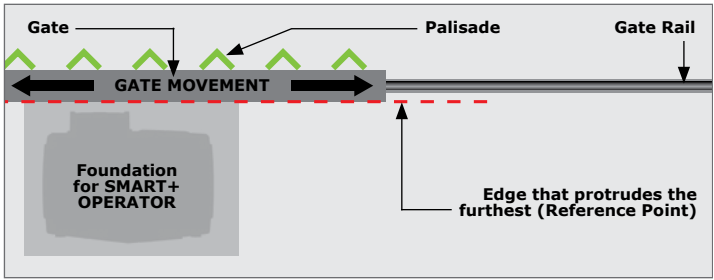


FIGURE 12

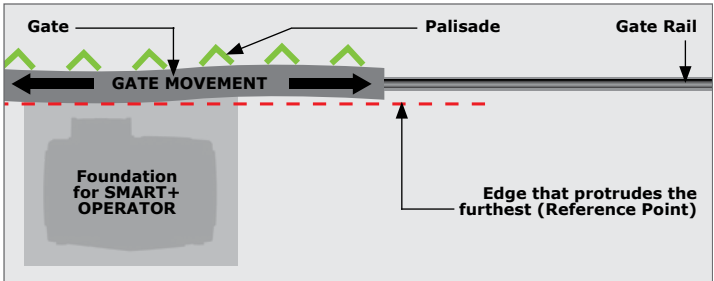


FIGURE 13

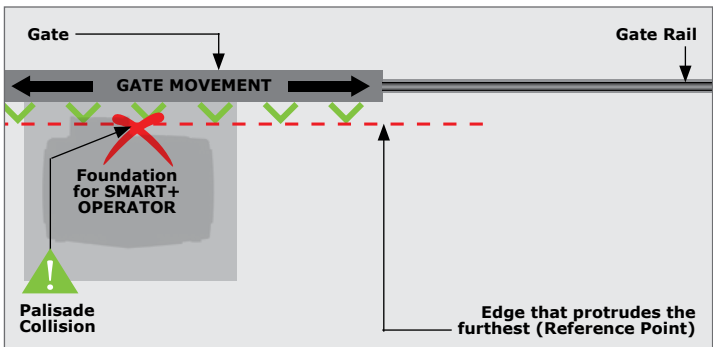


FIGURE 14

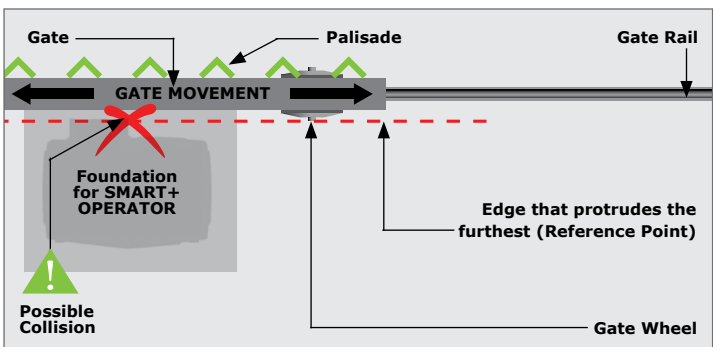


FIGURE 15

## 7.1.2. Minimum Clearances - Sides

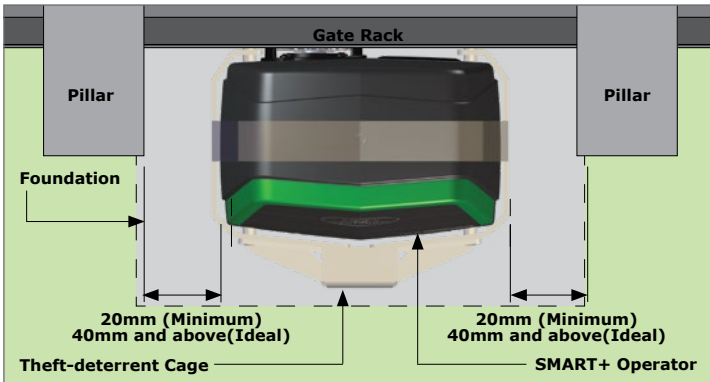


FIGURE 16. MINIMUM CLEARANCES - SIDES

## 7.1.3. Minimum Clearances - Front

## 7.1.3.1. D3 SMART+, D4 SMART+, D5-Evo SMART+, and D6 SMART+

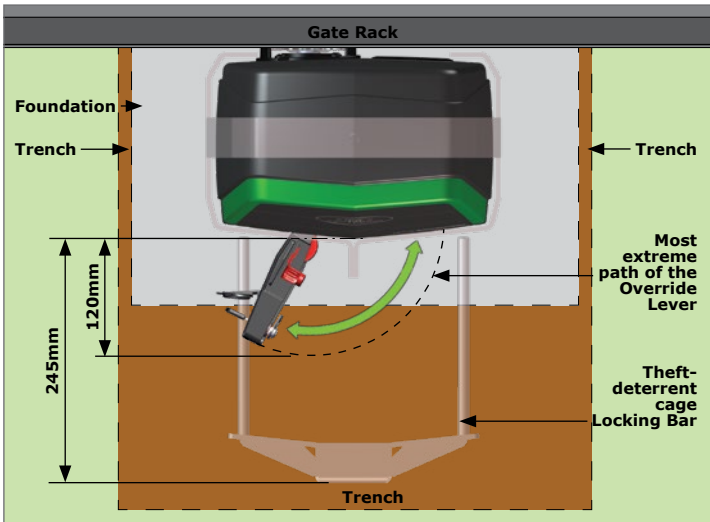


FIGURE 17. D3 SMART+, D4 SMART+, +D5-EVO SMART+, D6 SMART+

## 7.1.3.2. D10 SMART+, D10 TURBO SMART+, and D20 SMART+

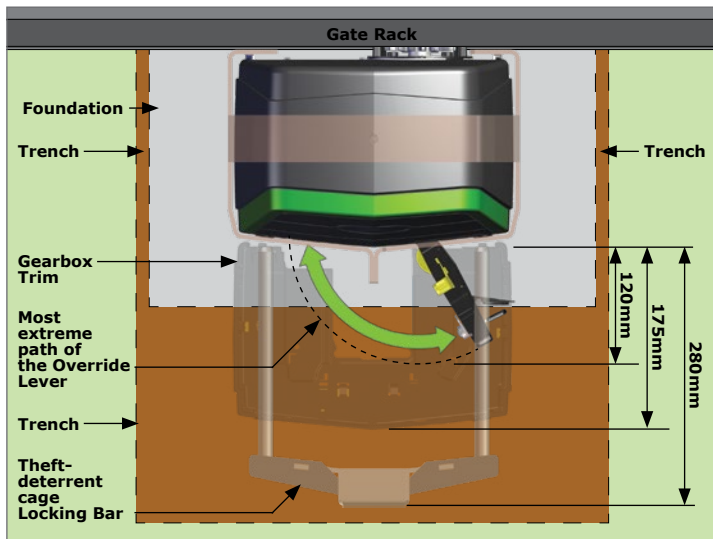


FIGURE 18. D10 SMART+, D10 TURBO SMART+, D20 SMART+

## 7.1.4. Locating the Operator's Position

To ensure that the operator does not protrude into the driveway, install the Foundation Plate at least flush with the driveway entrance.

It is typical to mount the rack above the pinion each type of rack considered. However, the rack mounted can be mounted underneath;

If there is space to mount the rack underneath without fouling the ground as the gate moves, the following are the pros and cons:

## Pros

- The rack is more hidden from view
- It provides a very effective anti-lift bracket
- It ensures that, since the gate beds in, the rack does not drop onto the pinion, loading the operator unnecessarily

## Cons

- Rack teeth face up vertically, potentially collecting dirt
- Could require the use of a custom bracket

The measurements given in Section 7.1.4.1. to Section 7.1.4.3. below are based on the three different racks supplied by Centurion Systems (Pty) Ltd and are to be used as guidelines only.

Quick Reference links;

**Steel Rack**

**D4 SMART+, D5-Evo SMART+, and D6 SMART+**

**D10 SMART+**

**D10 TURBO SMART+**

**D20 SMART+**

**RAZ Rack**

**D3 SMART+, D4 SMART+, D5-Evo SMART+, and D6 SMART+**

**Nylon Angle Rack**

**D3 SMART+, D4 SMART+, D5-Evo SMART+, and D6 SMART+**

[BACK TO SECTION INDEX](#)

[BACK TO CONTENTS](#)

## 7.1.4.1. Steel Rack



**Do not use a steel rack with the D3 SMART+ as this may cause damage to the pinion.**



The principles of installation on a Steel rack is to position in the middle of the output pinion with the operator fully forward on the slots.

## STEEL RACK - D4 SMART+, D5-EVO SMART+ and D6 SMART+

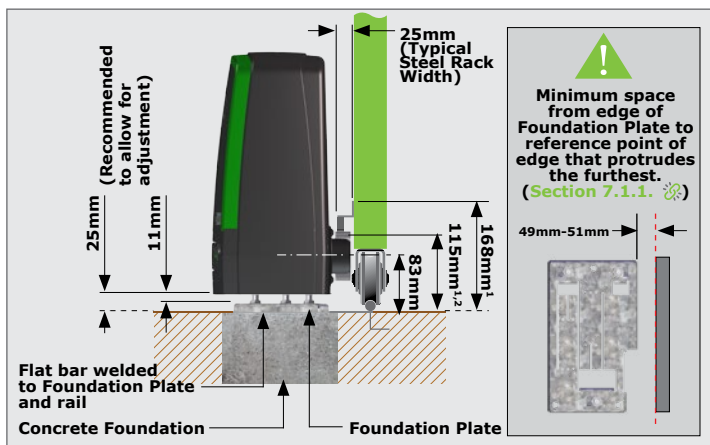


FIGURE 19. STEEL RACK ABOVE PINION - D4 SMART+, D5-EVO SMART+, D6 SMART+

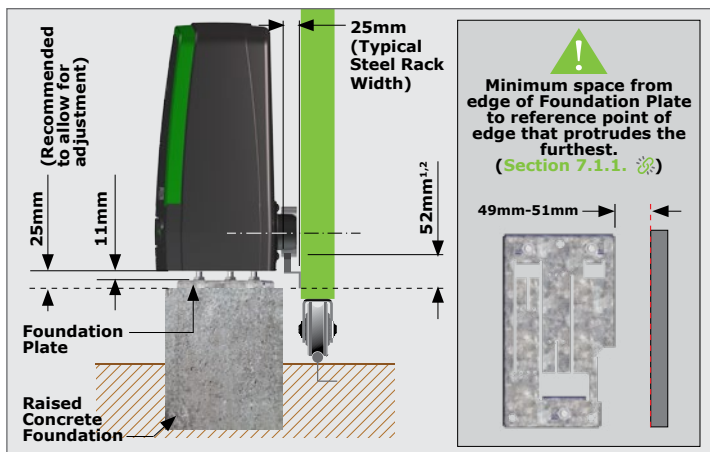


FIGURE 20. STEEL RACK BELOW PINION - D4 SMART+, D5-EVO SMART+, D6 SMART+

1. Includes 3mm clearance required between rack and pinion
2. Distance between bottom of the Foundation Plate and bottom edge of the Rack Tooth.

**BACK TO "SECTION 7.1.4. LOCATING THE OPERATOR'S POSITION"**

## STEEL RACK - D10 SMART+

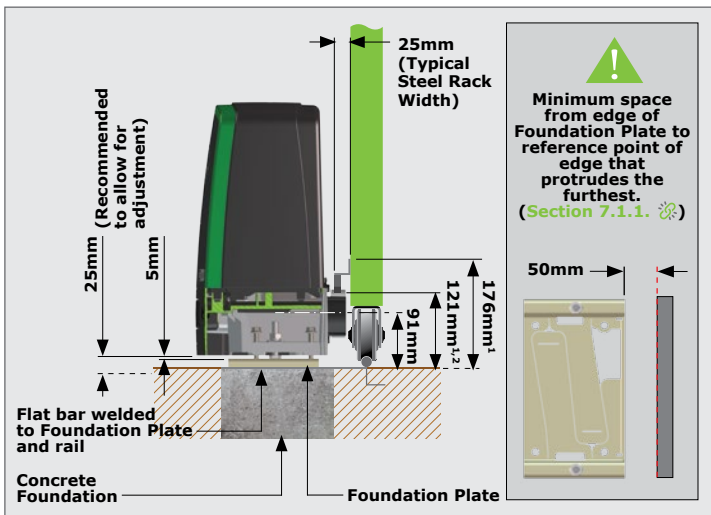


FIGURE 21. STEEL RACK ABOVE PINION - D10 SMART+

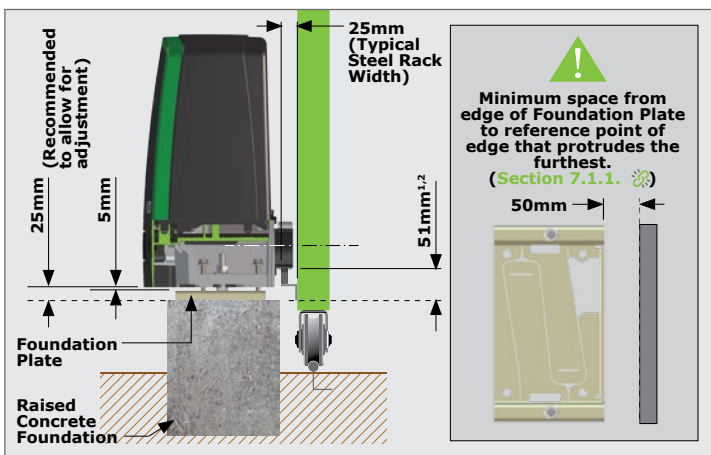


FIGURE 22. STEEL RACK BELOW PINION - D10 SMART+

1. Includes 3mm clearance required between rack and pinion
2. Distance between bottom of the Foundation Plate and bottom edge of the Rack Tooth



The Pinion Guard needs to be rotated 180 degrees if the rack below the pinion is desired for **ONLY** the **D10 SMART+** and **D20 SMART+**, and not the **D10 Turbo SMART+**.

🔗 [BACK TO "SECTION 7.1.4. LOCATING THE OPERATOR'S POSITION"](#)

## STEEL RACK - D10 TURBO SMART+

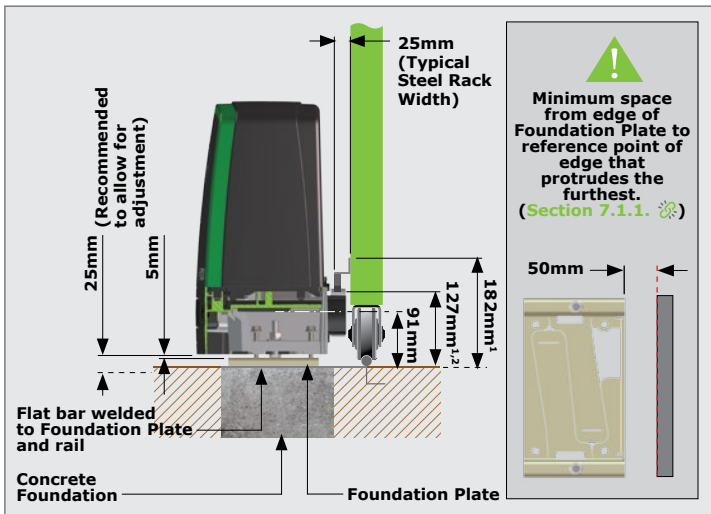


FIGURE 23. STEEL RACK ABOVE PINION - D10 SMART+

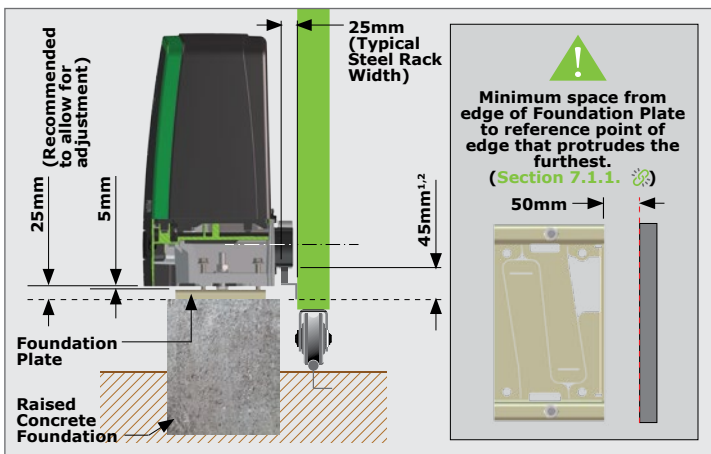


FIGURE 24. STEEL RACK BELOW PINION - D10 SMART+

1. Includes 3mm clearance required between rack and pinion
2. Distance between bottom of the Foundation Plate and bottom edge of the Rack Tooth

 **BACK TO "SECTION 7.1.4. LOCATING THE OPERATOR'S POSITION"**

## STEEL RACK - D20 SMART+

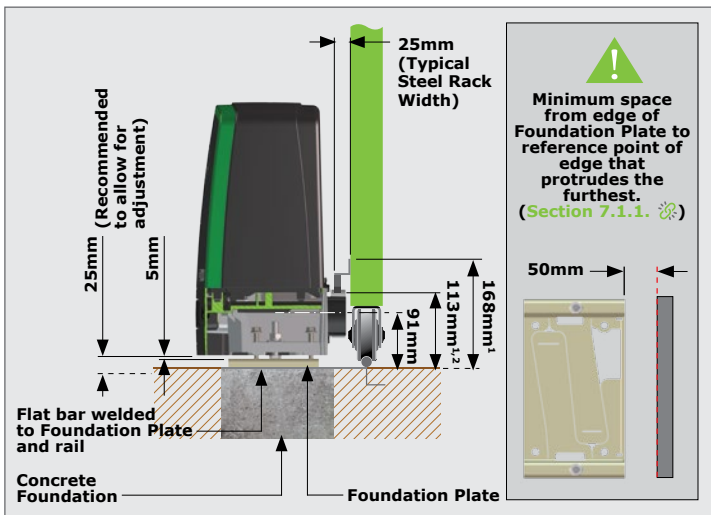


FIGURE 25. STEEL RACK ABOVE PINION - D10 SMART+

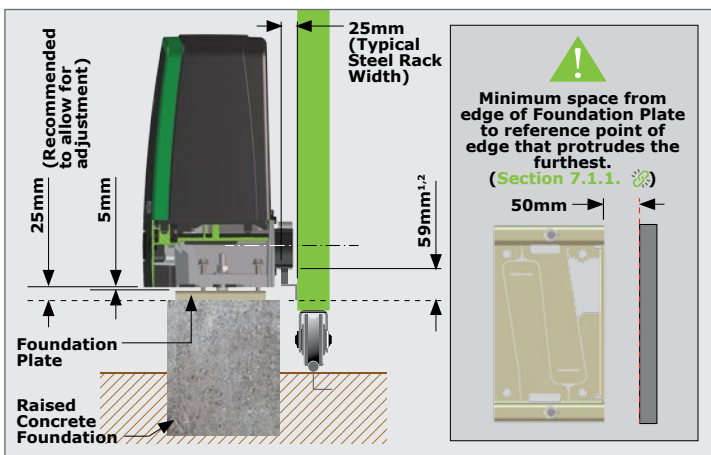


FIGURE 26. STEEL RACK BELOW PINION - D10 SMART+

1. Includes 3mm clearance required between rack and pinion
2. Distance between bottom of the Foundation Plate and bottom edge of the Rack Tooth



The Pinion Guard needs to be rotated 180 degrees if the rack below the pinion is desired for **ONLY** the **D10 SMART+** and **D20 SMART+**, and not the **D10 Turbo SMART+**.

🌀 [BACK TO "SECTION 7.1.4. LOCATING THE OPERATOR'S POSITION"](#)

## 7.1.4.2. RAZ Rack



The principles of installation on a RAZ Rack is to position in the middle of the output pinion with the operator fully forward on the slots.

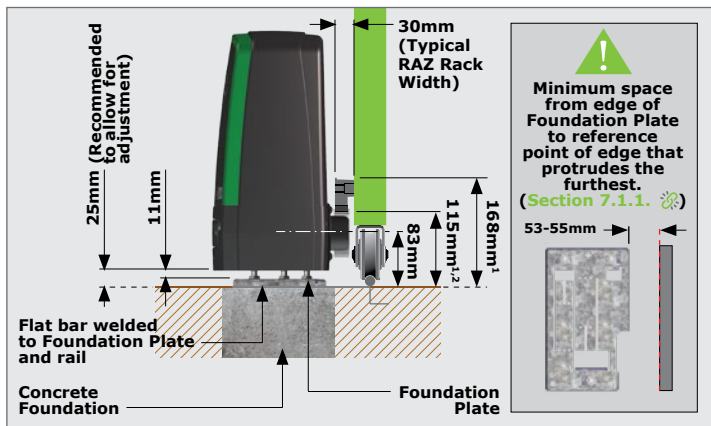
**RAZ RACK - D3 SMART+, D4 SMART+, D5-EVO SMART+ and D6 SMART+**


FIGURE 27. RAZ RACK ABOVE PINION

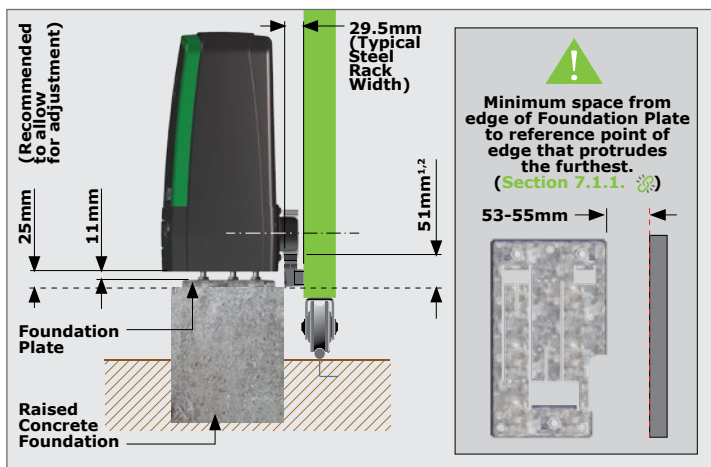


FIGURE 28. RAZ RACK BELOW PINION

1. Includes 3mm clearance required between rack and pinion
2. Distance between bottom of the Foundation Plate and bottom edge of the Rack Tooth

**BACK TO "SECTION 7.1.4. LOCATING THE OPERATOR'S POSITION"**

## 7.1.4.2. Nylon Angle Rack



The principles of installation on a Nylon Angle Rack is to position in the middle of the output pinion with the operator fully forward on the slots.

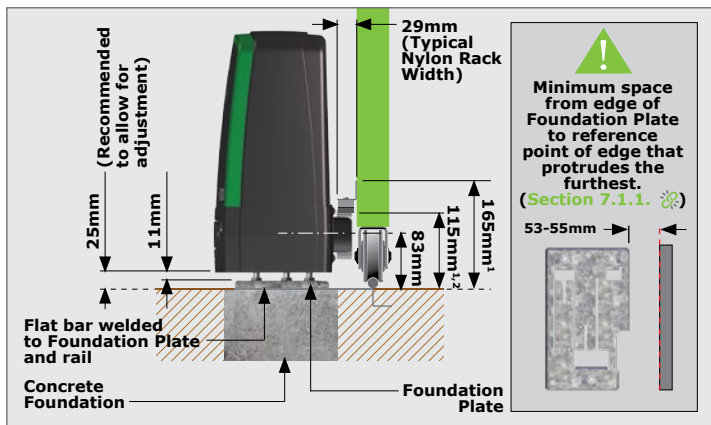
**NYLON ANGLE RACK - D3 SMART+, D4 SMART+, D5-EVO SMART+ and D6 SMART+**


FIGURE 29. NYLON RACK ABOVE PINION

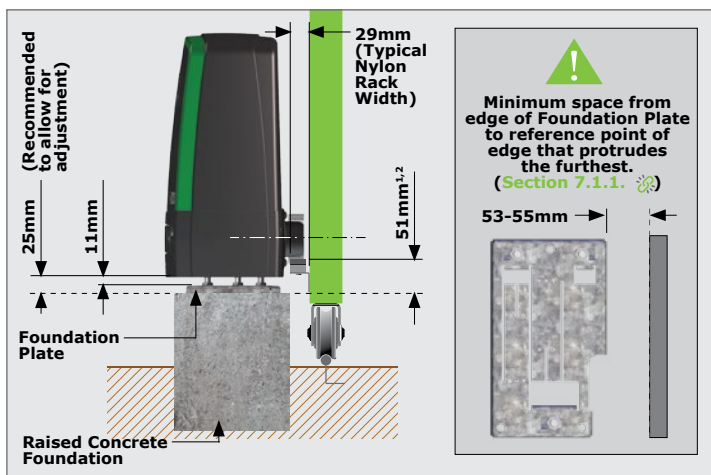


FIGURE 30. NYLON RACK BELOW PINION

1. Includes 3mm clearance required between rack and pinion
2. Distance between bottom of the Foundation Plate and bottom edge of the Rack Tooth

**BACK TO "SECTION 7.1.4. LOCATING THE OPERATOR'S POSITION"**

## 7.1.5. Foundation Plate Installation

## 7.1.5.1. Assembling the Foundation Plate



The Foundation Plate / Adaptor Plate is not supplied with the **SMART+ Operators**.

Place the mounting bolts through the holes of the relevant Foundation Plate and secure them into position using the half-nuts. The M10 half-nuts should be tightened to 20Nm.

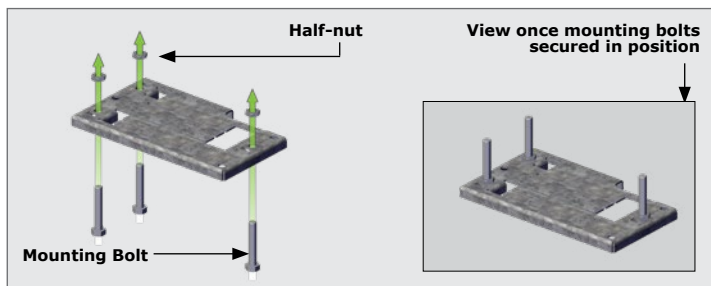


FIGURE 31. D3 SMART+ D4 SMART+, D5-EVO SMART+ AND D6 SMART+

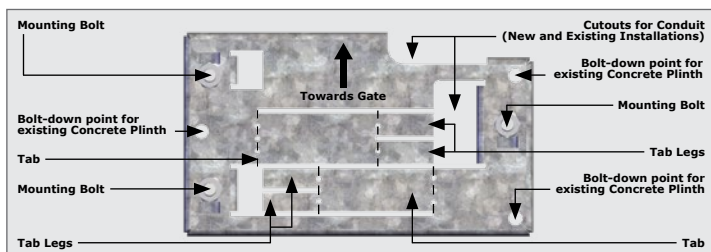


FIGURE 32. ASSEMBLED FOUNDATION PLATE

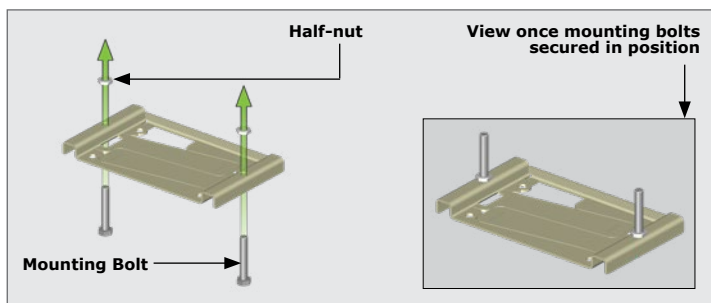


FIGURE 33. D10 SMART+, D10 TURBO SMART+ AND D20 SMART+

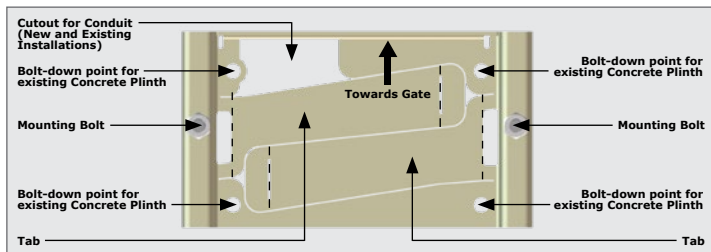


FIGURE 34. ASSEMBLED FOUNDATION PLATE



The Foundation Plate can either be set into a new concrete foundation, as in [Section 7.1.5.2](#) , or bolted down onto an existing concrete plinth as in [Section 7.2](#) .



Images may vary depending on the **SMART+ Operator** chosen for installation.

### 7.1.5.2. New Concrete Foundation

Using a pair of pliers, gently bend the two tabs of the Foundation Plate down to a 90° angle as shown in Figure 35.

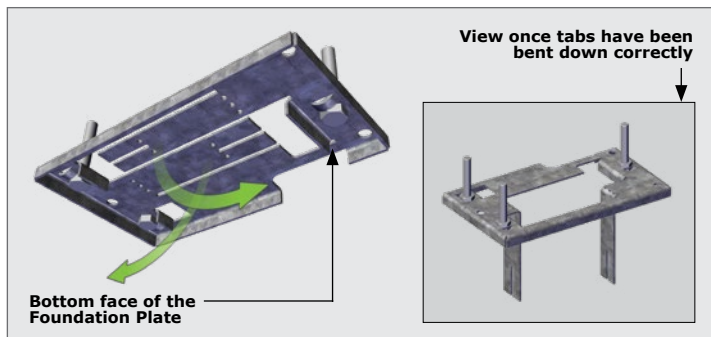


FIGURE 35

Again, using a pair of pliers, gently bend the two legs on each tab to an angle of 90° in opposite directions as shown in Figure 36.



This step is not applicable to the **D10 SMART+**, **D10 TURBO SMART+**, and **D20 SMART+** Foundation Plate

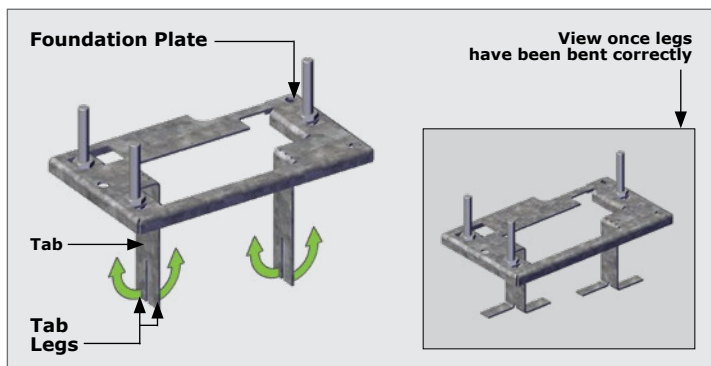


FIGURE 36



Lay the cabling conduit so that it routes the cables to the back of the Foundation Plate. Ensure that 30mm of conduit protrudes above the concrete.

Using medium-strength concrete (25MPa), cast the plinth according to the dimensions as shown in Figure 37.

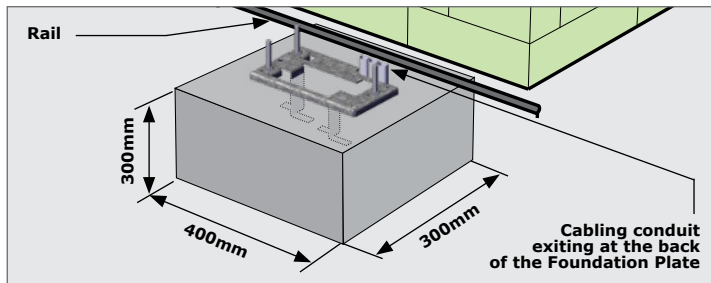


FIGURE 37

When using a concrete foundation, it is recommended that the foundation plate is welded to the rail/track of the gate using a short length of flat bar, as shown in Figure 38. This makes it possible to complete the whole mechanical and electrical installation without having to wait for the concrete to set. After completing the installation, the concrete can be poured and the operator left in manual mode until the concrete has set. Do not operate the motor until concrete has completely set.

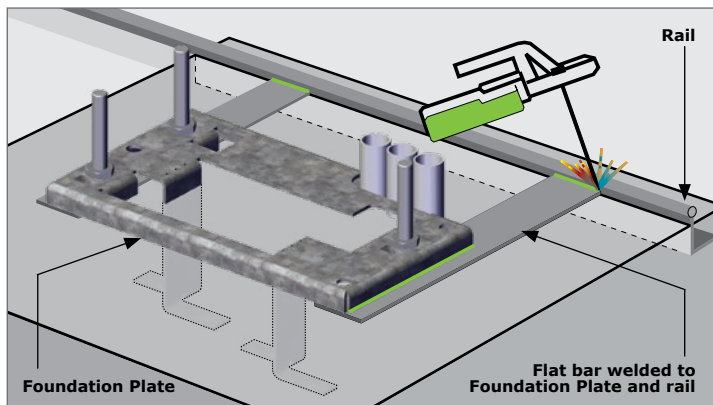


FIGURE 38

#### 7.1.5.3. Existing Concrete Plinth

If bolting onto an existing Concrete Plinth, place the foundation plate down in the correct position and use the plate as a template for marking the rawl bolt holes.



Check that the M10 half-nuts are tightened to 20Nm on the mounting bolts.



Rerouting of existing cables may be necessary.

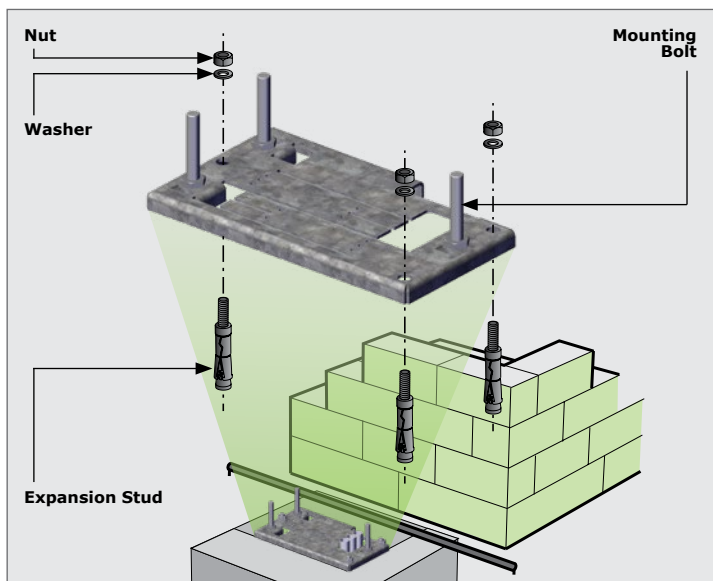


FIGURE 39

## 7.2. Retro-fit Installations (Existing Sites)

The **SMART+ Operator** has been designed to retro-fit into most existing installations, with the following provisions;

- If the unit is installed with the gate in the closed position and the unit on the left-hand side (from the inside of the property), the rack should extend at least 75mm past the centre line of the existing pinion
- If the existing unit is mounted with the maximum clearance to the Foundation Plate, the new unit will require that the rack be re-adjusted to obtain the correct mesh between the rack and pinion, as the existing bolts will be too short

If the existing Foundation Plate is in a good condition, it is not necessary to replace it with the **SMART+ Foundation Plate**. However, if the existing Foundation Plate is corroded or needs to be replaced for whatever reason, the **SMART+ Foundation Plate** can accommodate the existing footprint without the need to re-route cable conduits.

### 7.2.1. Retro-fitting if the Existing Foundation Plate is Unusable

Thoroughly inspect the existing Foundation Plate to determine whether or not it is fit to be reused. A foundation plate that is corroded, or otherwise damaged should be discarded and replaced with the **SMART+ Foundation Plate**.

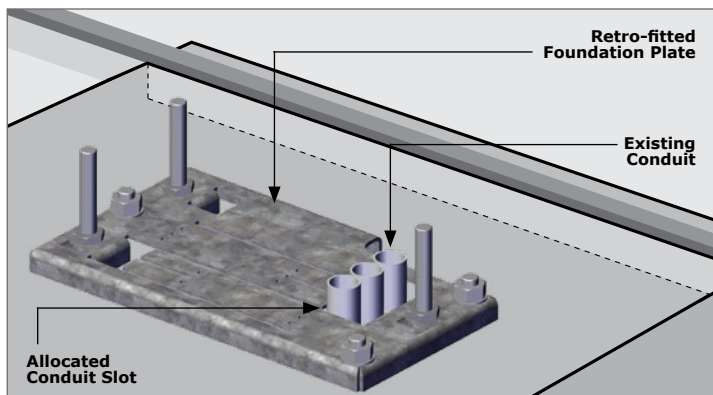


FIGURE 40



There is an allocated slot for existing conduit from previous D3, D5, and D5-Evo installations as shown in Figure 40.

## 7.3. Conduit and Cable Length

Route the cables as determined in [Section 5.5 - "Cabling Requirements"](#) .

Make sure that the conduits protrude above the concrete foundation.

For the **D3 SMART+**, **D4 SMART+**, **D5-Evo SMART+** and **D6 SMART+**, the mains cables should protrude 360mm above the concrete foundation, and all signal cables (i.e. beams, etc.) 550mm above the concrete foundation.

For the **D10 SMART+**, **D10 TURBO SMART+**, and **D20 SMART+**, the mains cables should protrude 450mm above the concrete foundation, and all signal cables (i.e. beams, etc.) 600mm above the concrete foundation.

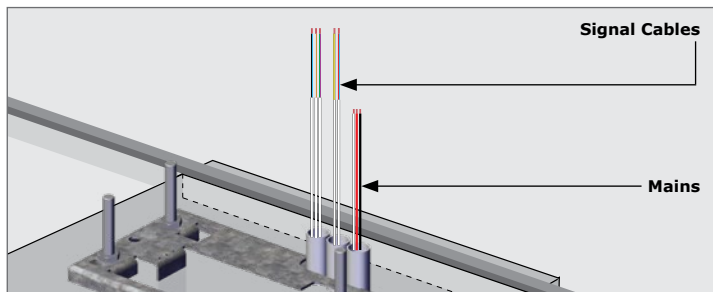


FIGURE 41

## 7.4. Preparing for installation



Images may vary depending on the **SMART+ Operator** chosen for installation.

Open the Camlock Cover, and insert the Operator Key into the Camlock. Unlock it by turning the key anti-clockwise.



There is no need to open the Release Handle to remove the cover.

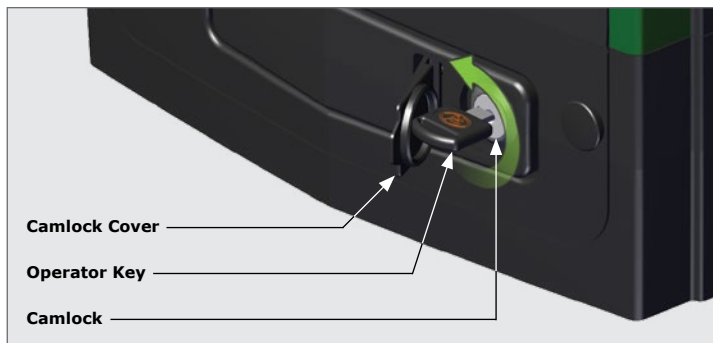


FIGURE 42

Remove the cover of the **SMART+ Operator** to expose the internal components, and place it one side in a safe location.

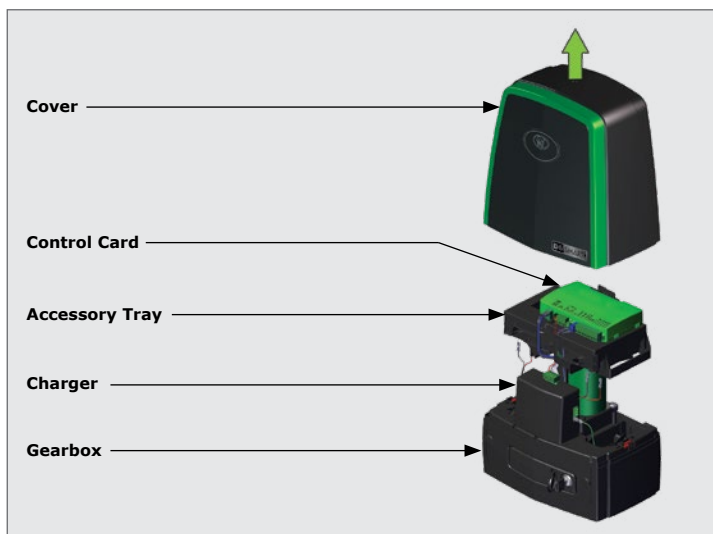


FIGURE 43

### 7.4.1. Removing the Charger

Disconnect the Charger from the **SMART+ Operator's** Control Card at either Point "A" or Point "B" depending on the Operator being used.



If the disconnection is made at Point "A", note that there are two connector blocks that need to be disconnected from the Control Card.

Disconnect the Earth Harness from the Charger at Point "C", and store it in a safe place.

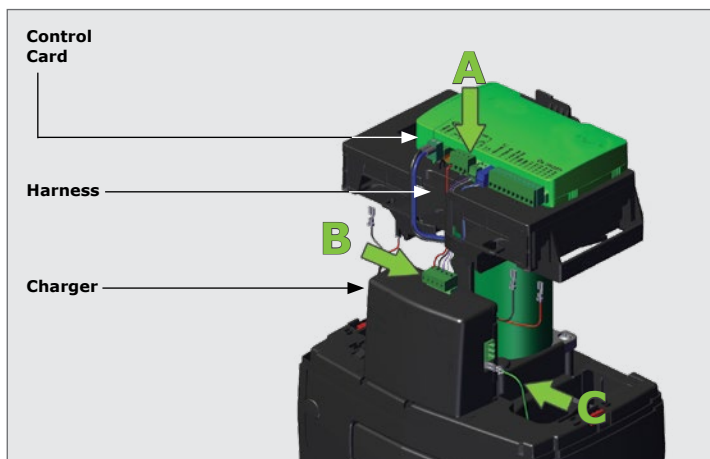


FIGURE 44

Remove the Charger from the Lower Battery Tray by gently pushing the Charger slightly down whilst pulling it towards the front of the **SMART+ Operator**. It should slide forward and off with ease.

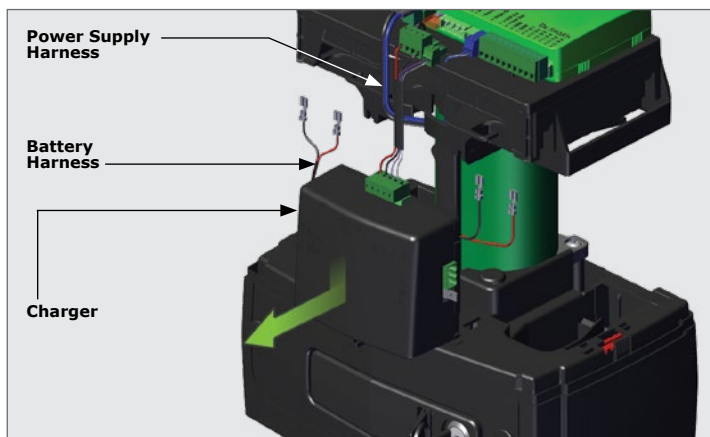


FIGURE 45

## 7.4.2. Removing the Lower Battery Tray / Gearbox Trim

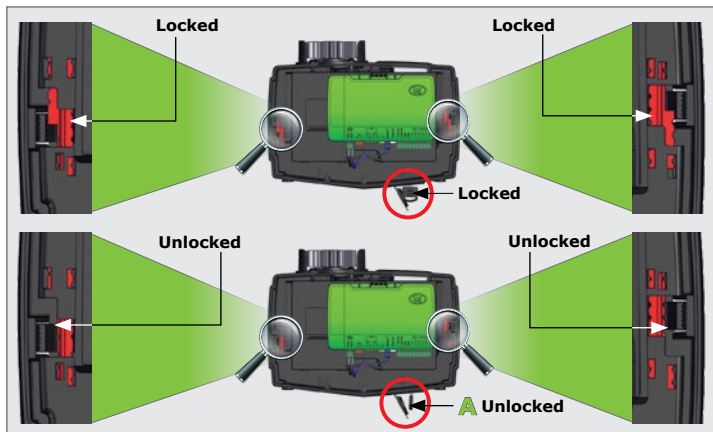


FIGURE 46

To remove the Lower Battery Tray, firstly ensure that the Camlock is in the “unlocked” position (Figure 46 marked as “A”). Note that the Camlock is on the Left of the gearbox for the **D10 SMART+**, **D10 TURBO SMART+**, and **D20 SMART+**.

Open the release handle until the Camlock Cam is visible (90° for the **D10 SMART+**, **D10 TURBO SMART+**, and **D20 SMART+**).

7.4.2.1. **D3 SMART+**, **D4 SMART+**, **D5-Evo SMART+** and **D6 SMART+**  
Lower Battery Tray

Using a flat screwdriver, lever the left and right Tabs inward, lift the Lower Battery Tray up, and then out towards the front of the **SMART+ Operator**.

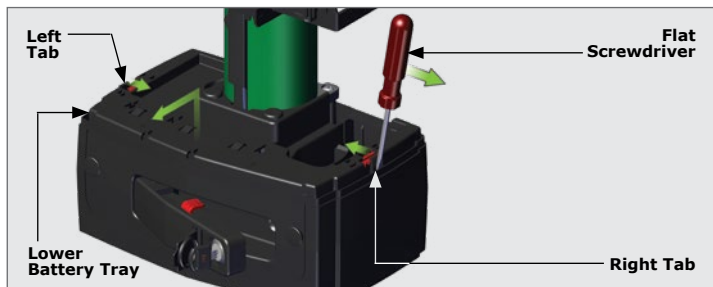


FIGURE 47

7.4.2.2. **D10 SMART+**, **D10 TURBO SMART+** and **D20 SMART+** Gearbox Trim

Remove the Camlock Key, and keep it in a safe place. Hold the gearbox trim on both sides firmly and pull the entire assembly forward with a slight tug towards the front of the **SMART+ Operator**. It will unclip from the rear of the gearbox. Manoeuvre it over the Manual Override Lever to remove it completely off the gearbox.

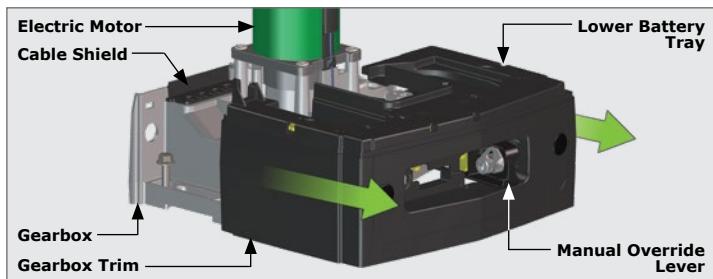


FIGURE 48

## 7.4.3. Removing the Control Card



Images may vary depending on the **SMART+ Operator** chosen for installation.

Disconnect the Plug with the Motor Wires at Point "D", and the Override Sensor Harness at Point "E" from the Control Card as Shown in Figure 49.



For the **D3 SMART+** and **D4 SMART+**, note that the motor wires will need to be removed with a screwdriver.

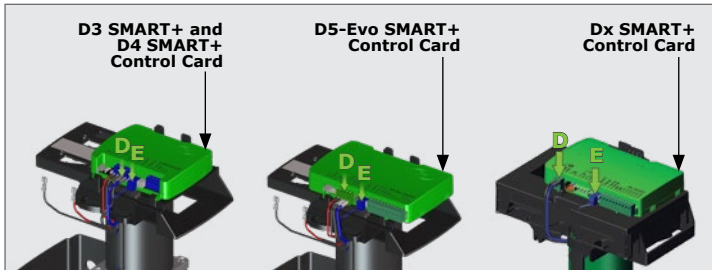


FIGURE 49

## 7.4.3.1 Hinging the controller forward

**D3 SMART+, D4 SMART+ and D5-Evo SMART+**

Remove the Control Card by pushing the tabs behind the Control Card backwards. This will allow the Control Card to hinge forward.

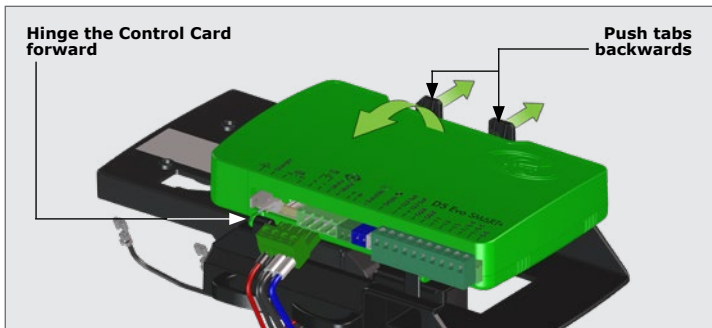


FIGURE 50

**Dx SMART+ Controllers**

Remove the Control Card by pushing the right tab behind the Control Card backwards. This will allow the Control Card to hinge forward.

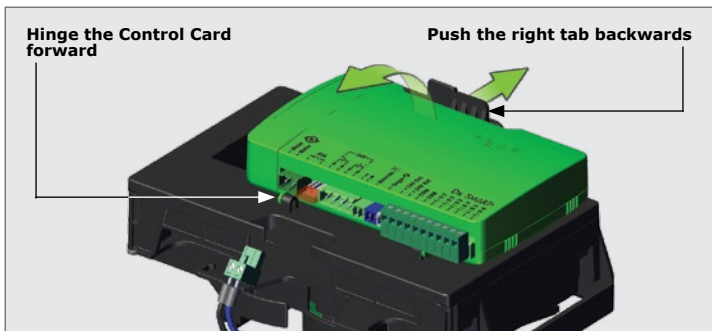


FIGURE 51

Lift the Control Card upwards and away from the **SMART+ Operator**, which will unhinge it from the hinge tabs found on the sides of the Control Card.



Take care not to snag the remaining harnesses in the harness retainers when removing the Control Card from the platform.

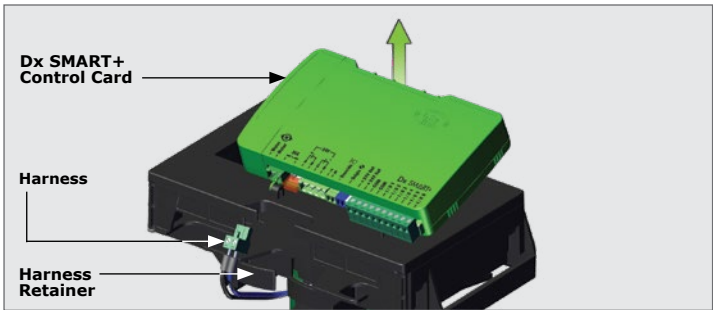


FIGURE 52

Store the Control Card in a safe place.

The **SMART+ Operator** is now ready to be mounted onto the Foundation Plate.

## 7.5. Mounting the Gearbox

### 7.5.1. D3 SMART+, D4 SMART+, D5-Evo SMART+ and D6 SMART+

For a new site installation, place a Half-nut and a Bottom Height Adjuster onto each Mounting Bolt as shown in Figure 53.



Note the orientation of the Bottom Height Adjusters.

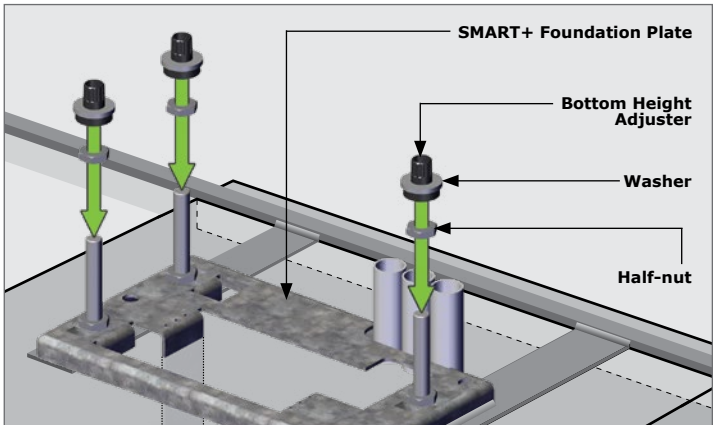


FIGURE 53

Adjust the Half-nuts to be 12mm clear from the Foundation Plate.

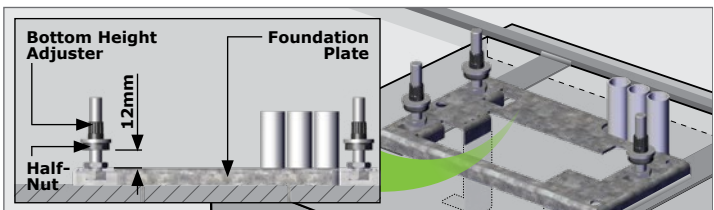


FIGURE 54

For a retro-fit installation, remove the original washers and height adjustment nuts from the existing foundation plate and then place a Half-nut and a Bottom Height Adjuster onto each existing Mounting Bolt, as shown in Figure 55.

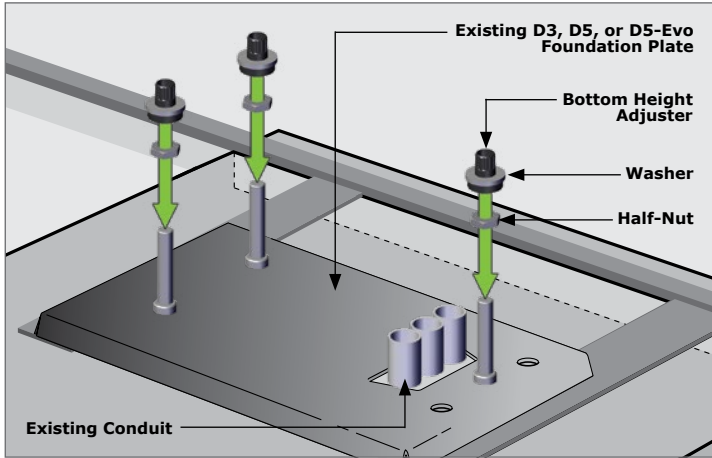


FIGURE 55



Note the orientation of the Bottom Height Adjusters.



If the existing unit was mounted with the maximum clearance to the foundation plate, the new unit will require that the rack be re-adjusted to obtain the correct mesh between the rack and pinion.

The Cable Shield needs to be removed before mounting the **SMART+ Operator** onto its Foundation Plate. This is done by levering the bottom end of the cable shield away from the motor until it unclips from the gearbox, and then slide it up.

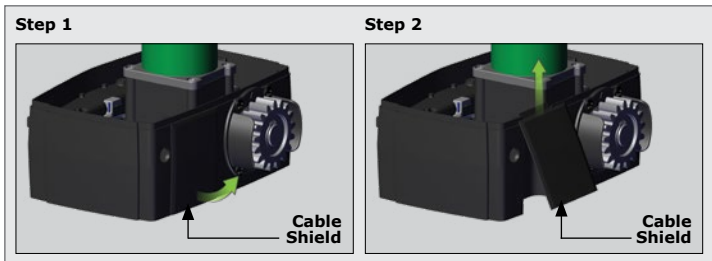


FIGURE 56

Once the Cable Shield has been removed, place the **SMART+ Operator** into position over the three Mounting Bolts, aligning them with the three slots at the bottom of the gearbox and rest the **SMART+ Operator** onto the Bottom Height Adjusters.

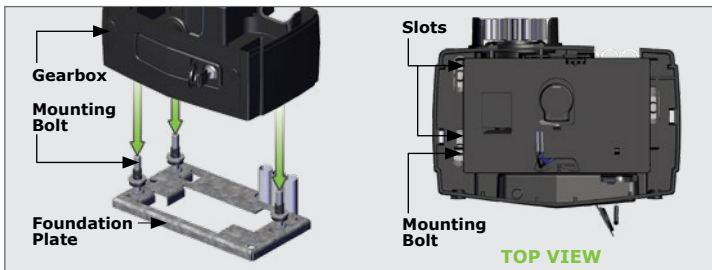


FIGURE 57

## 7.5.2. D10 SMART+, D10 TURBO SMART+ and D20 SMART+

The Cable Shield needs to be removed before mounting the **SMART+ Operator** onto its Foundation Plate. This is done by lifting the Cable Shield up and away from the gearbox.

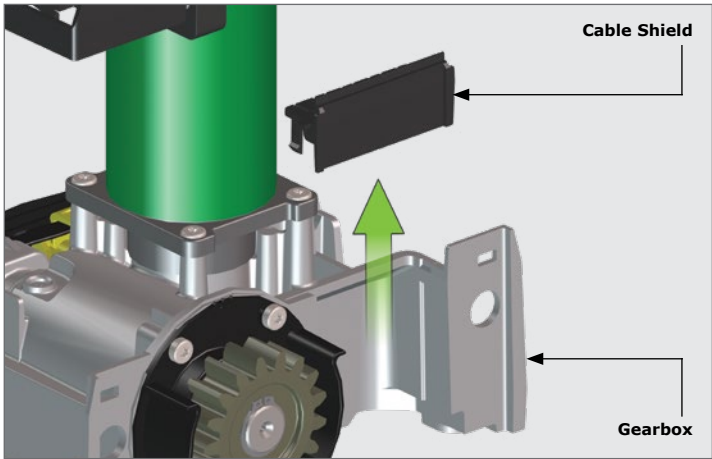


FIGURE 58

Once the Cable Shield has been removed, place the **SMART+ Operator** into position over the two Mounting Bolts, aligning them with the two slots at the bottom of the gearbox and rest the **SMART+ Operator** onto the Foundation Plate.

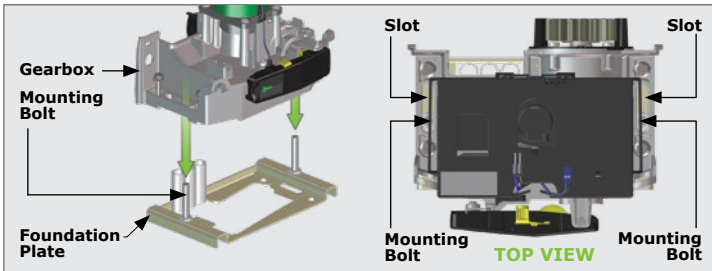


FIGURE 59

Once the Gearbox is resting on top of the Bottom Height Adjusters, slide the **SMART+ Operator** as far as possible towards the gate to allow for later adjustment.

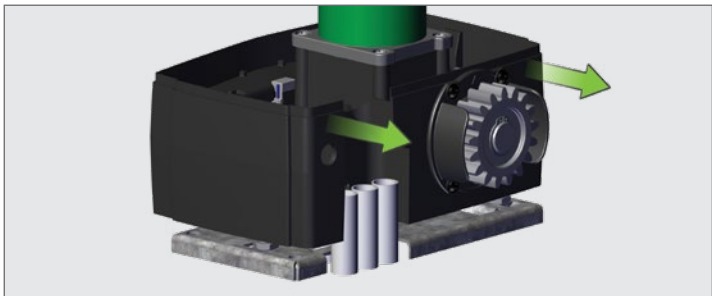


FIGURE 60

## 7.6. Routing the Cables

### 7.6.1. D3 SMART+, D4 SMART+, D5-Evo SMART+ and D6 SMART+

Route cables as determined in [Section 5.5 - "Cabling Requirements"](#) .

"Point A" is the entry point for cables with the conduit installed at the back of the unit for new installations as shown in Figure 61.

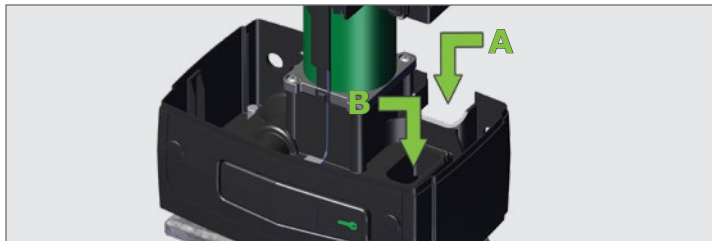


FIGURE 61

Although "Point B" is the entry point for cables with the conduit from existing D3, D5 and D5-Evo installations, it is recommended to route the cable under the gearbox and out the back through "Point A" as shown in Figure 62.

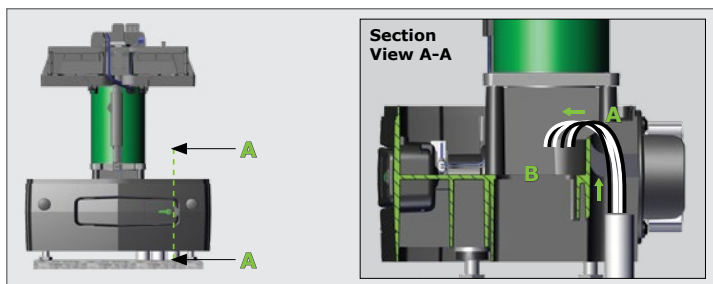


FIGURE 62. CABLE ROUTING FOR NEW INSTALLATIONS

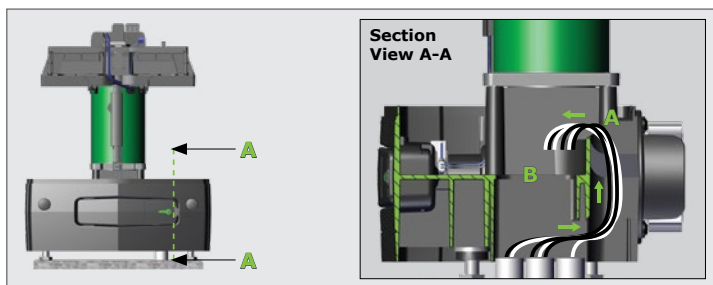


FIGURE 63. CABLE ROUTING FOR RETRO-FITS WITH LONGER CABLES



The method shown in Figure 63 above, is recommended for retro-fit installations, as it is easier to remove the motor should it be necessary to do so at a later stage. However, cable lengthening may be required.

Should the existing cables for a retro-fit installation be too short to route through "Point A" as shown in Figure 64 on the previous page, they can be routed directly through "Point B" to accommodate the shorter length. Note that routing the cables through "Point B" as shown in Figure 64, may make it more challenging to remove the **SMART+ Operator** for whatever reason at a later stage.

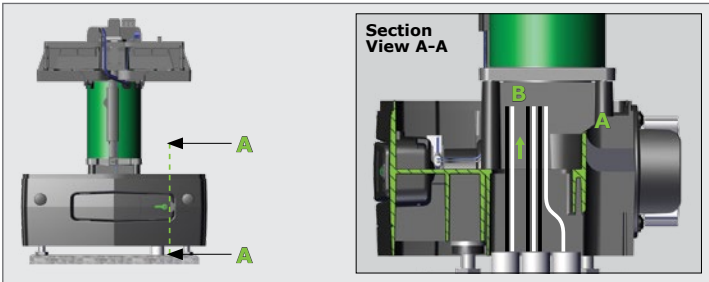


FIGURE 64. CABLE ROUTING FOR RETRO-FITS WITH SHORTER CABLES

### 7.6.2. D10 SMART+, D10 TURBO SMART+ and D20 SMART+

POINT A is the entry point for cables with the conduit installed at the back of the unit as shown in Figure 65.

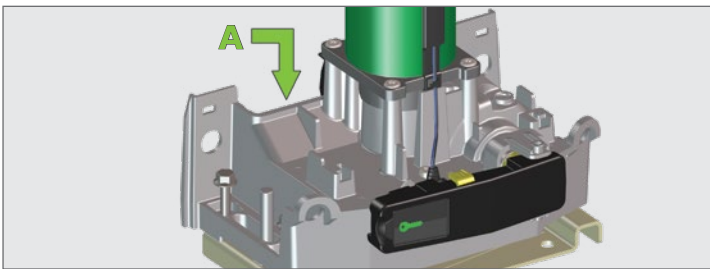


FIGURE 65

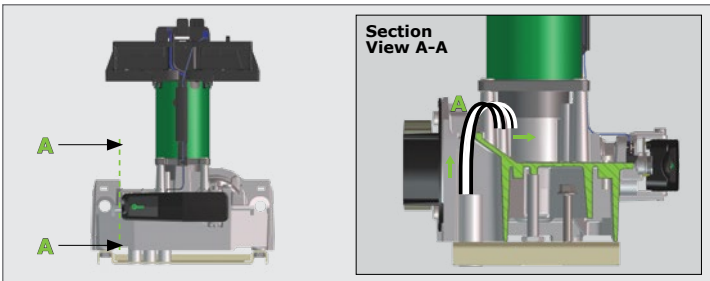


FIGURE 66. CABLE ROUTING FOR NEW INSTALLATIONS

## 7.7. Replacing the Cable Shields

### 7.7.1. D3 SMART+, D4 SMART+, D5-Evo SMART+ and D6 SMART+

Tilt the top of the Cable Shield towards the Gearbox, and slide it down so that the top of the Cable Shield is flush with the top edge of the Gearbox.



FIGURE 67

From the other side of the gate, firmly push the bottom sides of the Cable Shield inward, towards the gearbox.

Two clicks will be heard (one from each side of the Cable Shield) if the Cable Shield has engaged with the gearbox correctly.

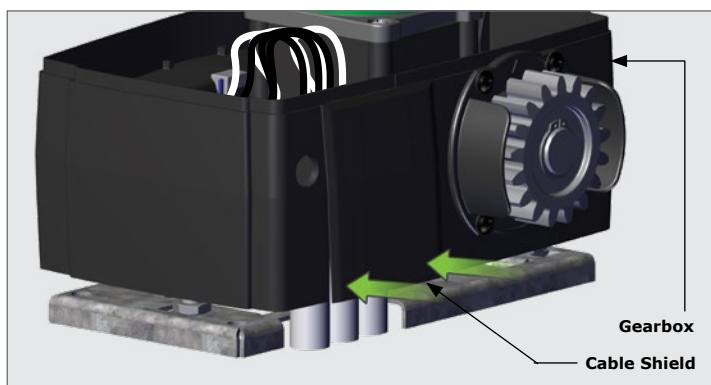


FIGURE 68

### 7.7.2. D10 SMART+, D10 TURBO SMART+ and D20 SMART+

The Cable Shield has punch-outs on it which cater for both Mains Cables and Communication cables. Punch out the holes which are needed and place the Cable Shield back into position onto the gearbox whilst guiding the cables through the holes.

There is a groove on either side of the Cable Shield to guide it into position.

Press firmly down, and you will hear a “click” once the Cable Shield has located correctly.

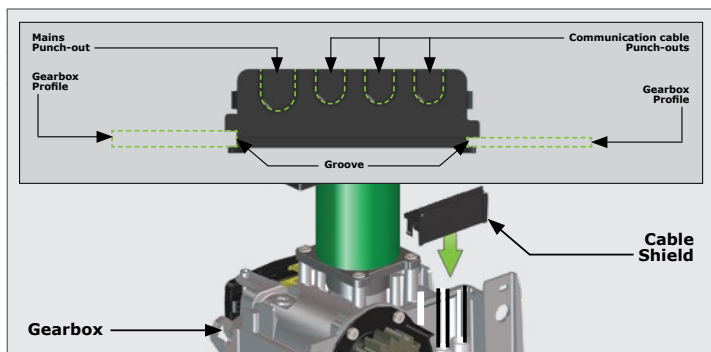


FIGURE 69

## 7.8. Manual Override



Images may vary depending on the **SMART+ Operator** chosen for installation.



**Before mounting the rack to the gate, ensure that the SMART+ Operator is in Manual Override. Follow the instructions below.**

To disengage (Manual Override) the motor, ensure that the Camlock is in the "unlocked" position, and pull the Release Handle as far left as it will go. The Motor will then be placed in a temporary state of disengagement.

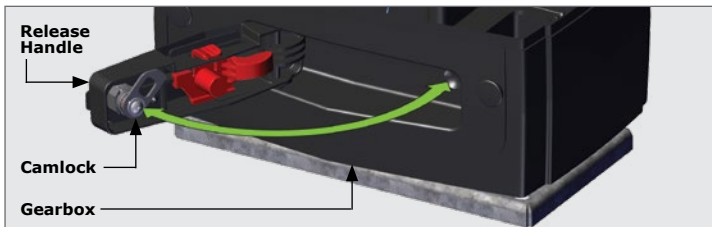


FIGURE 70

### Manual Override Latching

In the event of a power failure, it may be required to lock the cover in place whilst "latching" the manual release (i.e. manual release permanently enabled). This helps prevent theft of the unit, or its components, and provides full protection from the elements.

With the release handle in the open position, slide the Override Cam located on the inside of the handle towards the gearbox, and a "click" can be heard once it has located correctly. Return the handle to the closed, or locked, position. This allows continued manual operation of the gate while ensuring that the cover remains securely locked in place. See Figure 71.

To re-engage the **SMART+ Operator** (i.e. take the operator out of latched Manual Override), push the Release Handle Override Cam to the left and then slide it towards the Camlock. See Figure 72.

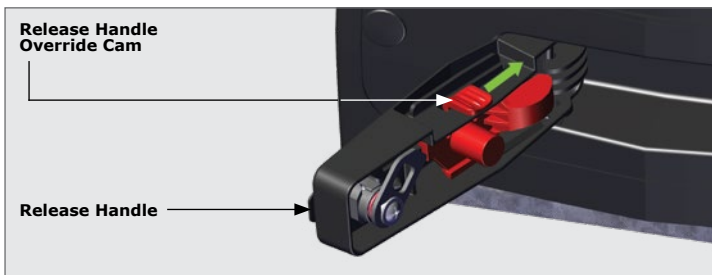


FIGURE 71

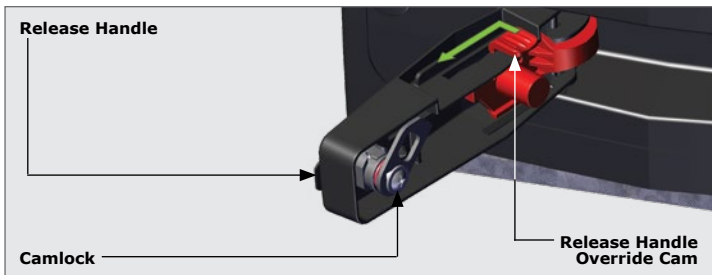


FIGURE 72



The Manual Override Lever is mirrored on the **D10 SMART+**, **D10 TURBO SMART+**, and **D20 SMART+**

## 7.9. Height Adjustment

The **SMART+ Operator's** unique Height Adjustment System adjusts from the top of the gearbox. This adds further security to the system, as it is not possible to access the lock nuts from the outside of the gearbox.

### 7.9.1. D3 SMART+, D4 SMART+, D5-Evo SMART+ and D6 SMART+

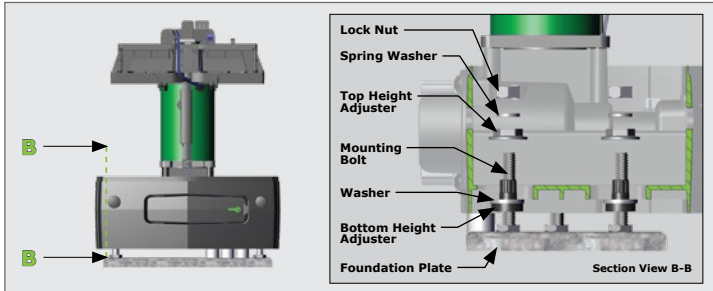


FIGURE 73

Only add the Spring Washers and Lock Nuts once the Rack has been installed and the operator height is correct. See Section 7.10.2. - "Finalising the Height Adjustment" .

Place a Top Height Adjuster onto each Mounting Bolt so that it engages with the teeth on the Bottom Height Adjuster.

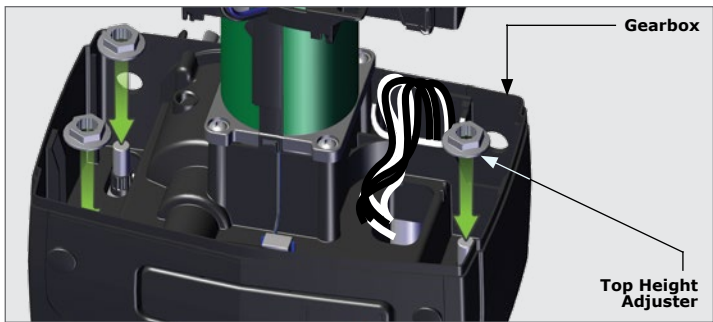


FIGURE 74

Note the orientation of the Top Height Adjuster as shown in Figure 73 and 74.

Using a ratchet and a 19mm socket, turn the Top Height Adjuster anti-clockwise to lift the Operator, or turn it clockwise, to lower the Operator.

Using a spirit level, ensure that the Operator is level. If not, use the Height Adjusters to level the Operator.

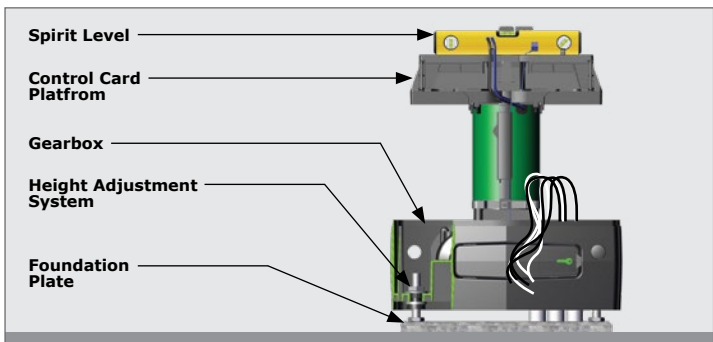


FIGURE 75

## 7.9.2. D10 SMART+, D10 TURBO SMART+ and D20 SMART+

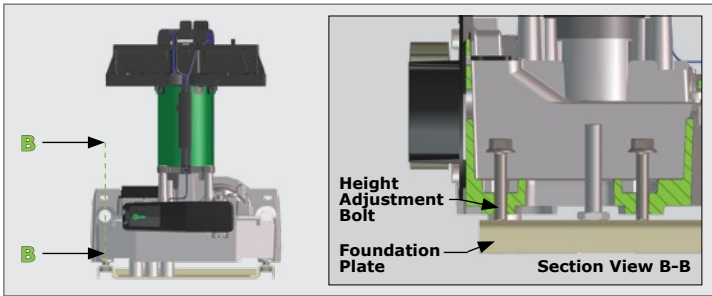


FIGURE 76

Using a ratchet and a 12mm socket, turn the Height Adjustment Bolt clockwise to lift the Operator, or turn it anti-clockwise, to lower the Operator.

Using a spirit level, ensure that the Operator is level. If not, use the four Height Adjustment Bolts to level the Operator.



Lubricating the Height Adjustment Bolts with Q20 or a similar general purpose lubricant will make adjusting the bolts easier.

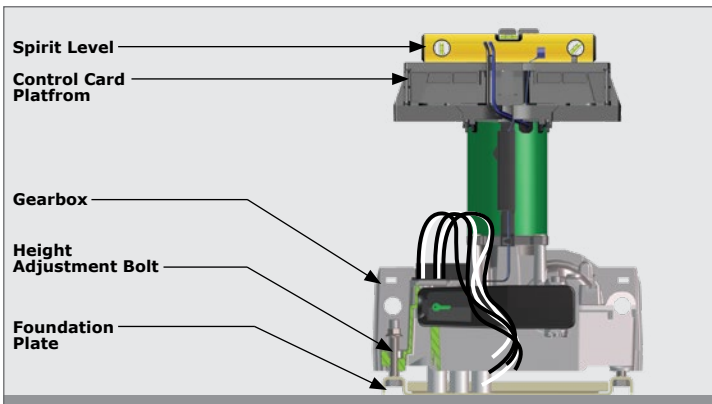


FIGURE 77

INTRO

SPECS

PARTS

TOOLS

NEW SITES

OIL

INSTALL

FINISH

LOW-VOLT CHARGER

WIRING

SERVICE

EXTRAS

HAND OVER

WARRANTY

## 7.10. Mounting the Rack



Images may vary depending on the **SMART+ Operator** chosen for installation.



**The Rack must be securely mounted to the side of the gate. It must be parallel with the gate rail, and there must be a 2-3mm gap between the Rack teeth and the teeth of the Pinion.**

Before mounting the rack, raise the operator an additional 3mm.

Ensure that the **SMART+ Operator** Gearbox is in Manual Override. Refer back to Section 7.8 - "Manual Override" .

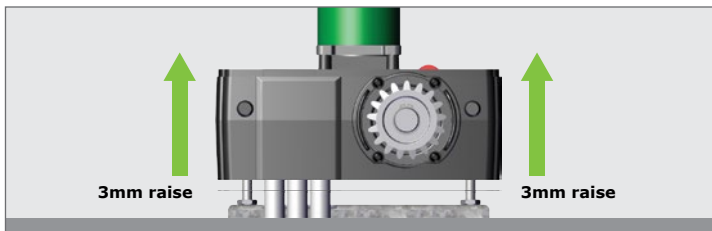


FIGURE 78

Start with the gate either fully-open or fully-closed.

Slide the **SMART+ Operator** back towards the gate to where the Pinion will sit just under where the rack will be fixed to the gate.

Rest the rack directly onto the Pinion (let it mesh fully) while welding / bolting the rack into position.

Level the other end and fix that end to the side of the gate, as shown in Figure 80.

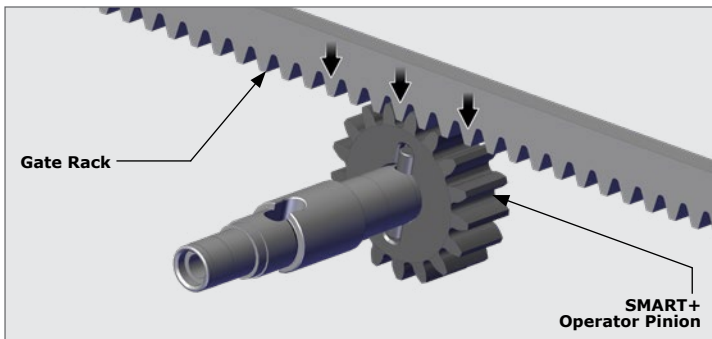


FIGURE 79

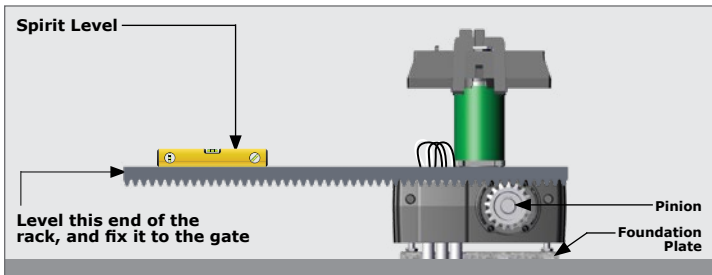


FIGURE 80. THE RACK AND OPERATOR FROM THE GATE'S PERSPECTIVE



Refer to the instructions on how to fix the different types of rack to a gate in Section 7.10.1. - "Fitting Different Types of Rack to the Gate" .

Slide the gate halfway along the first section and level the unsecured end, ensuring that the rack is resting on the Pinion, not pressing down. Continue this way to fix all sections.



Before fully fixing each section of rack, slide the gate backwards and forwards along the section, checking that the rack is only resting on the Pinion, and not pressing down onto it.

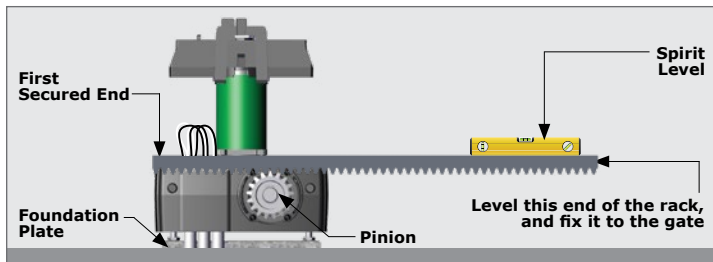


FIGURE 81. THE RACK AND OPERATOR FROM THE GATE'S PERSPECTIVE

Lower the operator 3mm to achieve the required 3mm tooth clearance.

Ensure that operator mounting bolts are securely tightened.

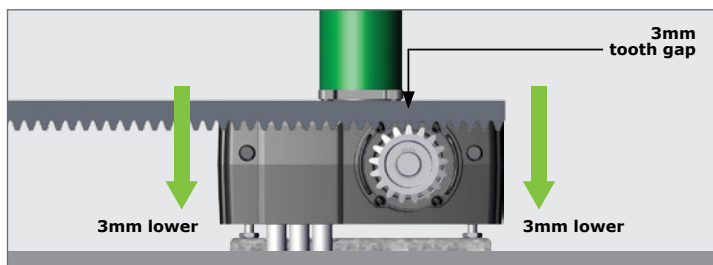


FIGURE 82

### 7.10.1. Fitting Different Types of Rack to the Gate

#### Steel Rack



**Do not use a steel rack with the D3 SMART+ as this may cause damage to the pinion.**

Fix the Steel Rack with the steel angle brackets provided. The brackets must be spaced no more than 300mm apart.

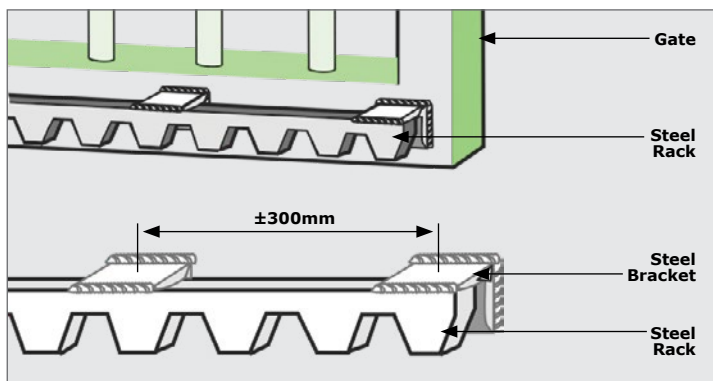


FIGURE 83

When joining different lengths of Steel Rack, a simple way of ensuring that the correct pitch spacing is achieved, is to clamp a small off-cut between the two pieces.

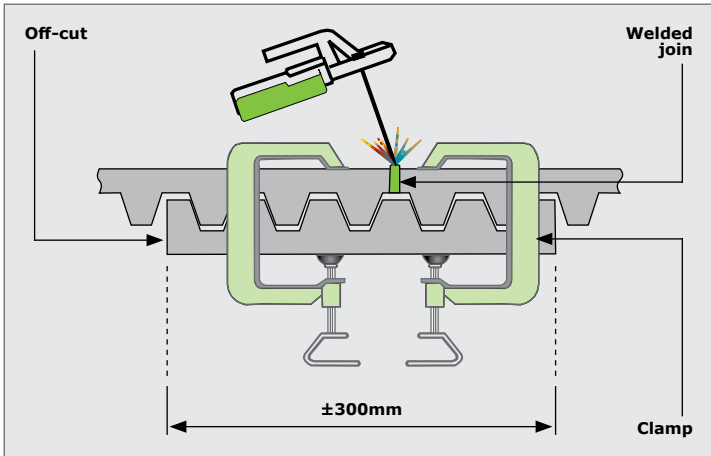


FIGURE 84

### RAZ Rack

**⚠ Not recommended for D10 SMART+, D10 TURBO SMART+ and D20 SMART+**

Fix the RAZ Rack to the side of the gate using the TEK screws provided. Use the vertical slots in order to allow for adjustment.



Do not weld the off-cut to the gate or the join.

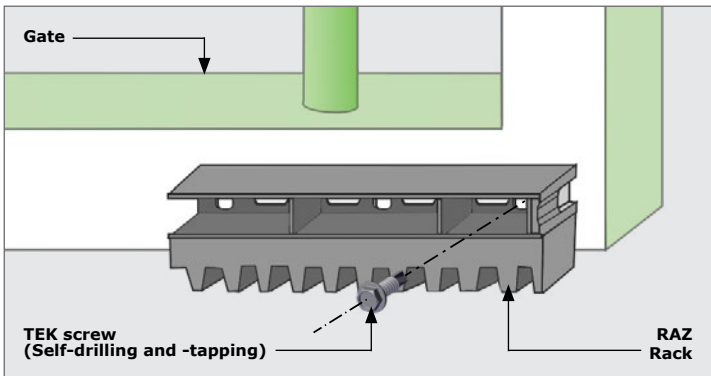


FIGURE 85

When fitting RAZ Rack, it is easier to start on the right and work towards the left. The RAZ Rack sections simply interlock with each other.

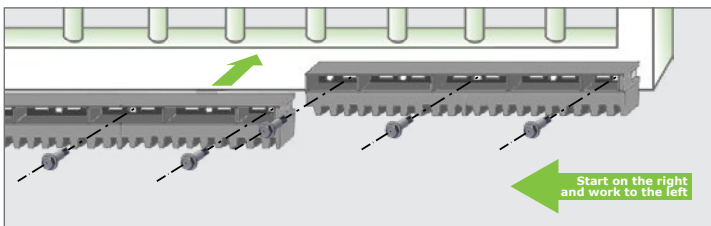


FIGURE 86

Fit an additional fixing screw through the horizontal slots to secure the rack to the gate directly above the Pinion when the gate is in the closed, pedestrian and open positions as shown in Figure 87.



Fit an addition screw through the horizontal slots at the ends of each section of Rack to further strengthen the joins.

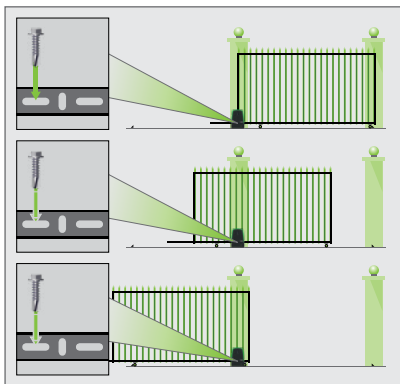


FIGURE 87

### Nylon Angle Rack



**Not recommended for D10 SMART+, D10 TURBO SMART+ and D20 SMART+**

Fix the Rack to the side of the gate using TEK screws.



Ensure that all the mounting holes provided in the angle section are used.

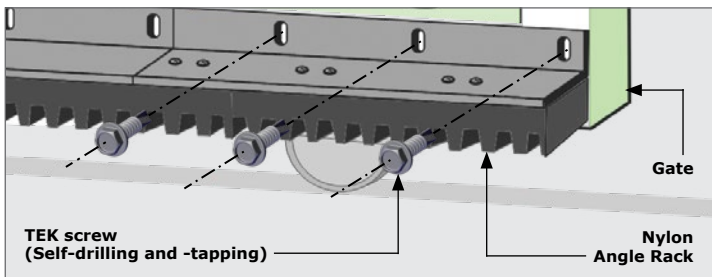


FIGURE 88

When joining two lengths together, simply butt each section firmly together to ensure that the correct pitch is achieved.

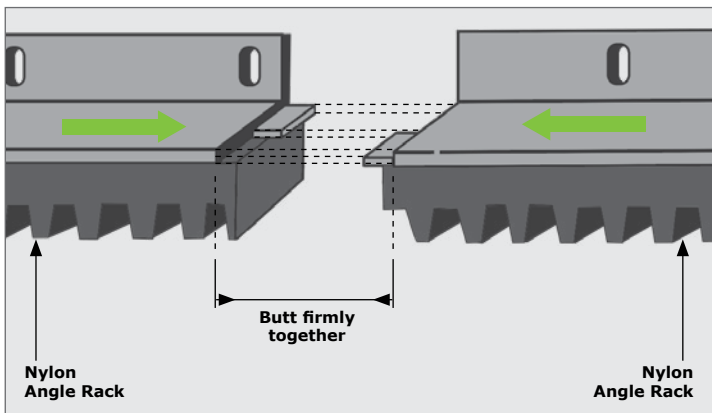


FIGURE 89



Images may vary depending on the **SMART+ Operator** chosen for installation.

### 7.10.2. Finalising the Height Adjustment



Slide the **SMART+ Operator** away from the gate so that the rack is centred above the Pinion.

Final adjustment to the position of the gearbox should be done at this point.

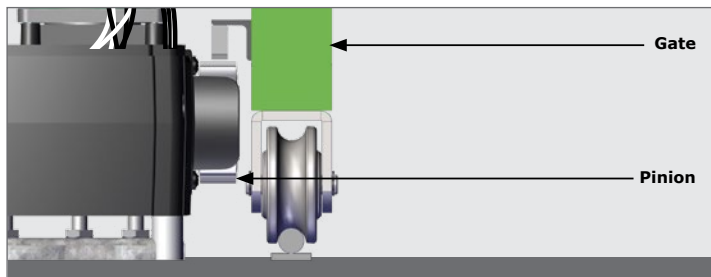


FIGURE 90

#### 7.10.2.1. Placing and Routing the Earth Harness

Place the Ring Lug-end of the Earth Harness onto the mounting bolt on the right-hand side of the Gearbox.

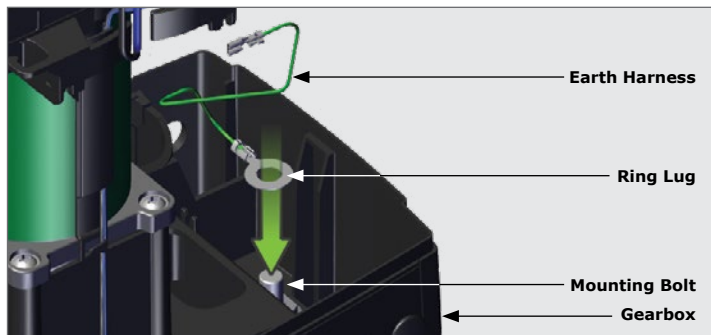


FIGURE 91



To ensure that the Earth Harness is able to reach the Charger once connected to the mounting bolt, it is recommended that it is positioned at the angle depicted by the middle line, but not at an angle exceeding the lines at either side of it as the Earth Harness will not be able to reach the Charger.

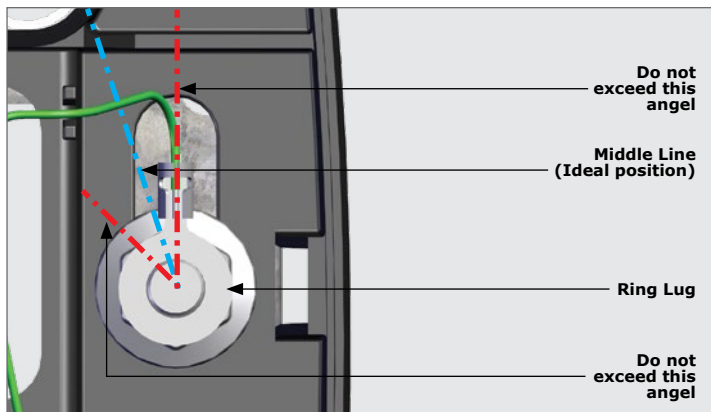


FIGURE 92

Route the Earth Harness up to the left and place it into the Cable Management Clip as shown in Figure 93.



The Earth Harness will need to be routed under the battery at a later stage.

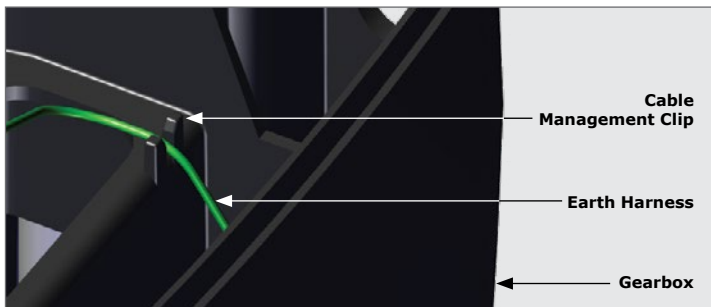


FIGURE 93

7.10.2.2. Placing the Spring Washers and Lock Nuts



Only add the Gearbox Mounting Washers, Spring Washers and Lock Nuts once the Rack has been installed and the operator height is correct.

Place one Gearbox Mounting Washer, one Spring Washer and one Lock Nut onto each of the Mounting Bolts. Tighten all of the Lock Nuts with a 17mm socket to secure the height of the **SMART+ Operator** firmly in position.

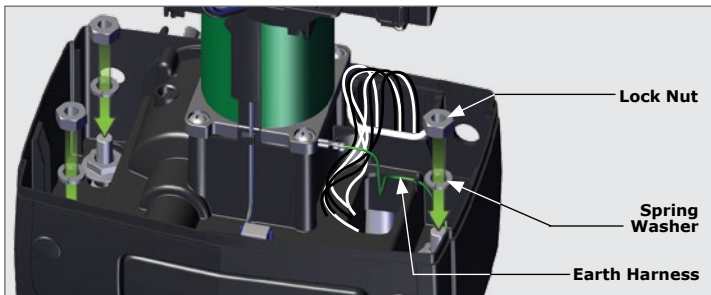


FIGURE 94. D3 SMART+, D4 SMART+, D5-EVO SMART+ AND D6 SMART+

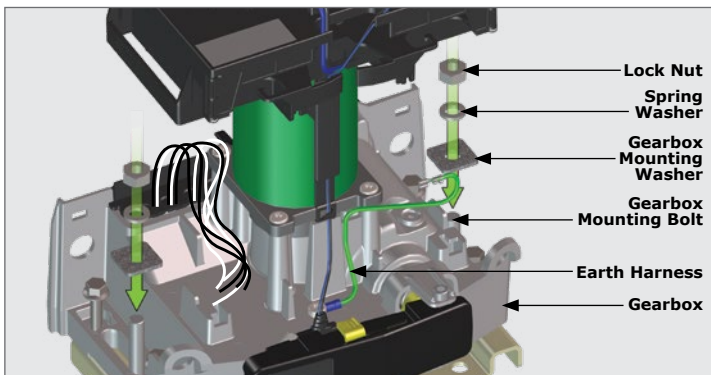


FIGURE 95. D10 SMART+, D10 TURBO SMART+ AND D20 SMART+

## 7.11. Reassembling the SMART+ Operator

### 7.11.1. D3 SMART+, D4 SMART+, D5-Evo SMART+ and D6 SMART+

#### 7.11.1.1. Override Sensor



If the Override Sensor has previously been removed, take note of how it is placed back into position correctly, before continuing with the installation.

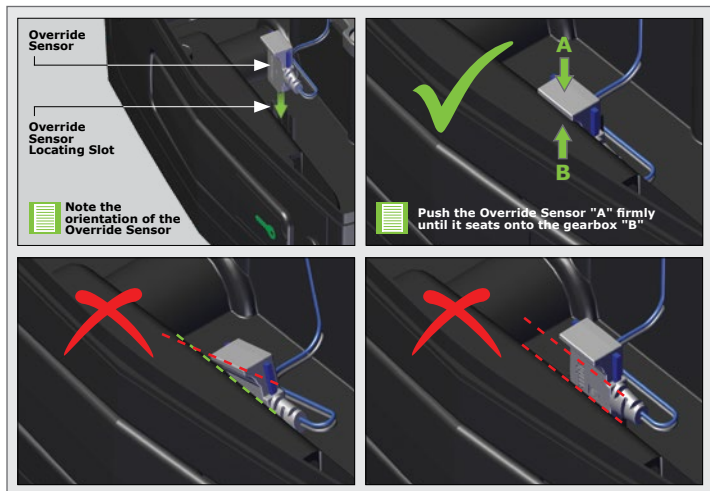


FIGURE 96. OVERRIDE SENSOR

#### 7.11.1.2. Routing the Override Sensor Harness



It is important to ensure that the harness for the Override Sensor is routed through the correct location when inserting the Lower Battery Tray back into position.

The Override Sensor harness is routed directly in front of the electric motor. There is a groove located in the middle of the Lower Battery Tray, on the motor's side. The harness needs to be routed between the electric motor and the Lower Battery Tray here as the Lower Battery Tray is placed back into position.

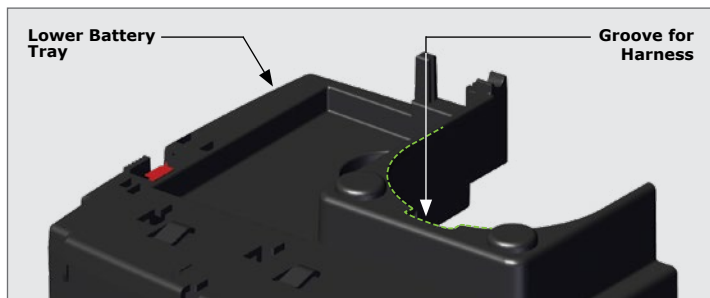


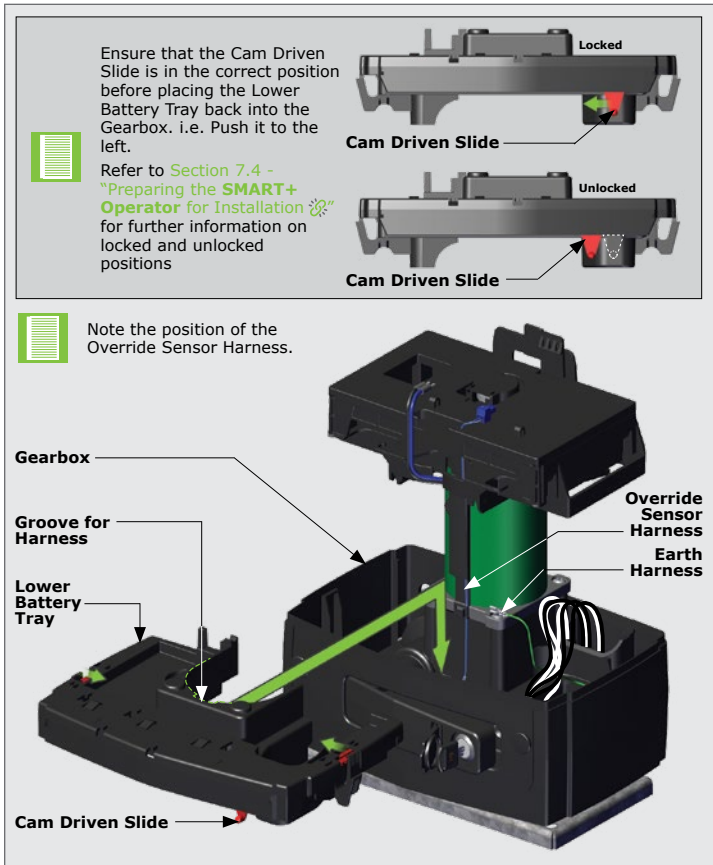
FIGURE 97

## 7.11.1.3. Placing the Lower Battery Tray into position



Ensure that the Camlock is in the "unlocked" position and that the Release Handle is partially open.

Place the Lower Battery Tray into position. Whilst doing this, route the cabling and harnesses through. A click from both sides will be heard if the tray is fitted correctly.



## 7.11.2. D10 SMART+, D10 TURBO SMART+ and D20 SMART+

## 7.11.2.1. Placing the Lower Battery Tray into position



Ensure that the Camlock is in the "locked" position and that the Manual Override Lever is open to the 90° position.

Ensure that the Manual Override Lever is in the open position, and slide the Gearbox Trim into position. Whilst doing this, route the Earth harnesses through. A click from both sides will be heard if the tray is fitted correctly.

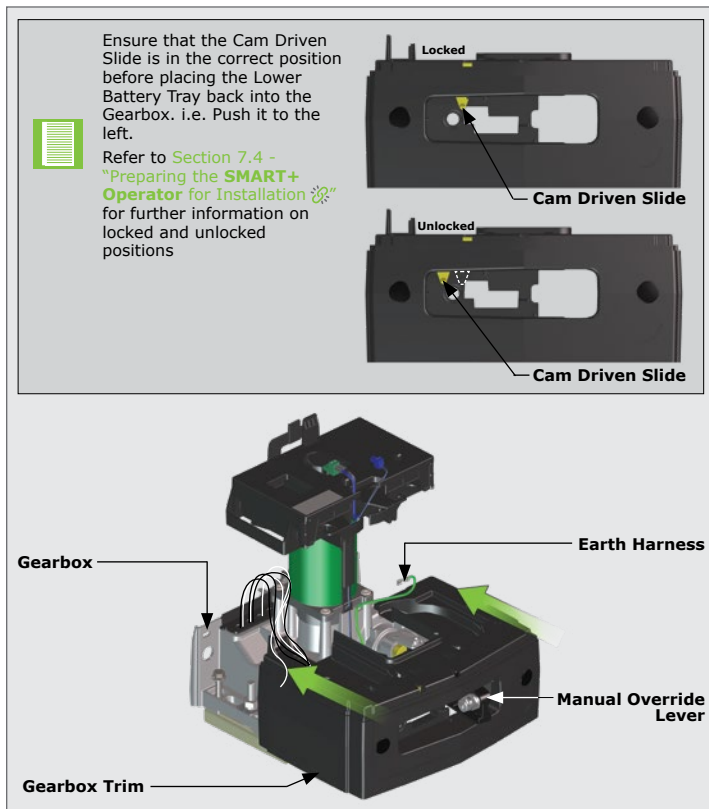


FIGURE 99. GEARBOX TRIM PLACEMENT

### 7.11.3 Placing the Charger back into Position

Place the Charger back into position by aligning the three feet at the bottom of the Charger with the three slots found on top of the Lower Battery Tray.

Place the studs of the Charger into the three holes on the Lower Battery Tray. Firmly press the Charger down, and push it toward the Electric Motor, sliding it along the slots.

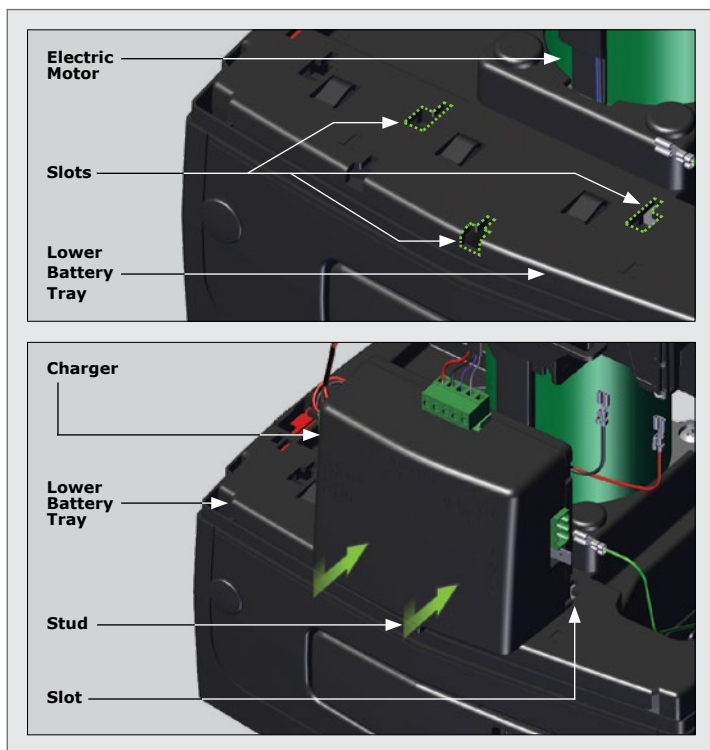


FIGURE 100. GEARBOX TRIM PLACEMENT

### 7.11.4 Placing the Control Card back into Position

Tilt the control card and align the gaps with the clips shown in Figures 101 and 102 depending on the Controller in use.

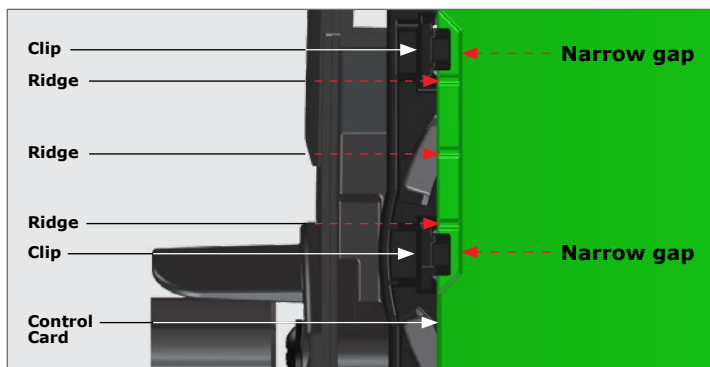


FIGURE 101. D3 SMART+, D4 SMART+ AND D5 E-EVO SMART+ CONTROL CARD

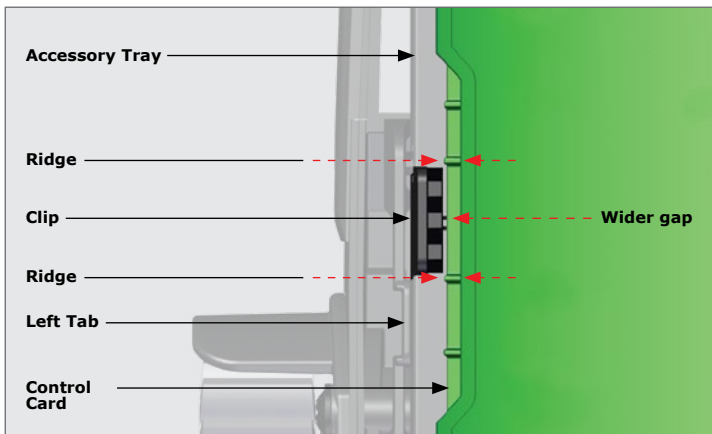


FIGURE 102. D6 SMART+, D10 TURBO SMART+, D10 SMART+ AND D20 SMART+ CONTROL CARD

Once aligned, hinge the Control Card under the tab's lip, and firmly press downward on both sides in front of the Control Card.

This will engage the Control Card into the hinges at the front of the Accessory Tray. A click from both sides will be heard if this is done correctly.

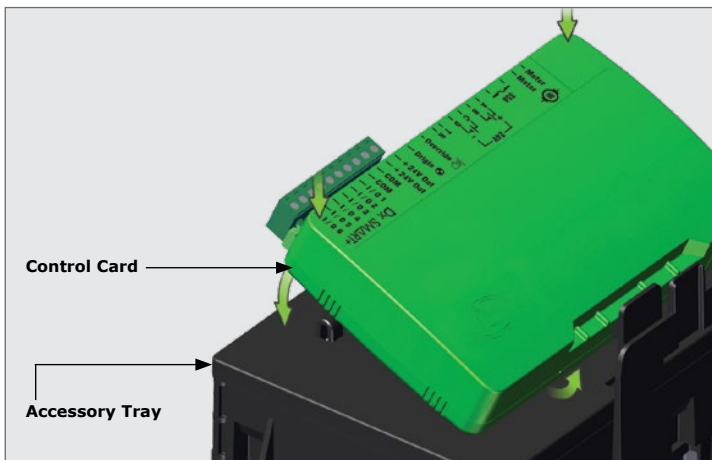


FIGURE 103

### 7.11.5 Reconnecting the Harnesses to the Control Card and Charger

Reconnect the Motor Wires at Position "A" and the Override Harness at Point "B" on the Control Card.

**! The black motor wire is connected on the left, and the blue on the immediate right of the black.**

**! Ensure harness wires are correctly connected. Check the illustrations carefully! Each variation of controller differs!**

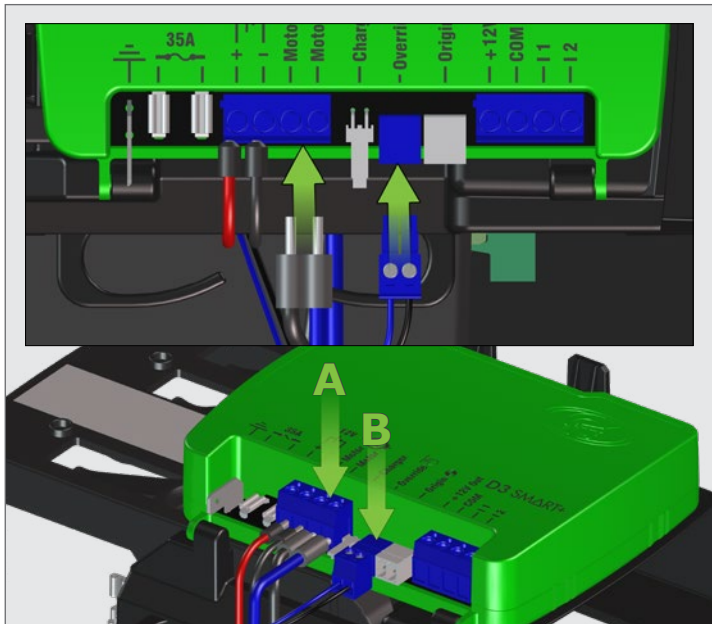


FIGURE 104. D3 SMART+ AND D4 SMART+ CONTROLLER

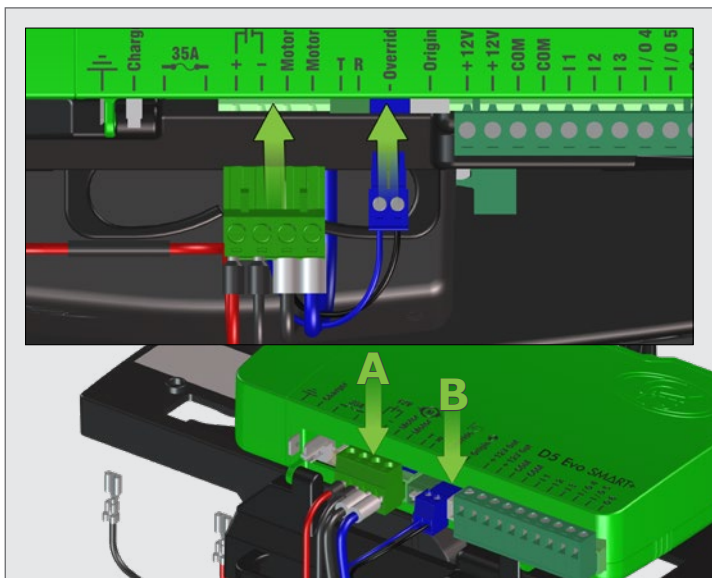


FIGURE 105. D5-EVO SMART+ CONTROLLER

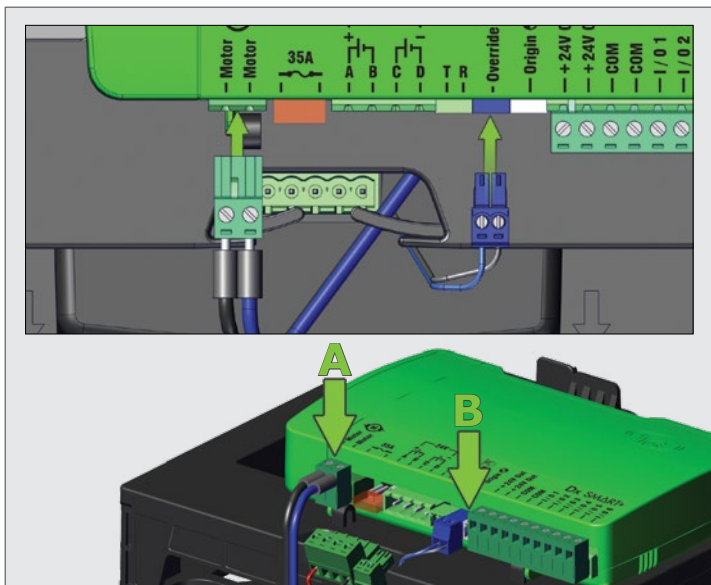


FIGURE 106. D5 SMART+, D10 TURBO SMART+, D10 SMART+ AND D20 SMART+ CONTROLLER

Reconnect the Charger Harness to the point from which it was disconnected earlier at position "C", and the earth harness at position "D" on the Control Card.



Utilise the Cable Retainers at the bottom of the accessory storage to neaten up the wiring, and the overall installation.

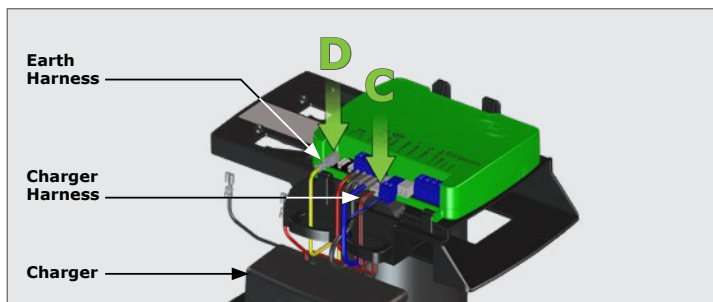


FIGURE 107. D3 SMART+ AND D4 SMART

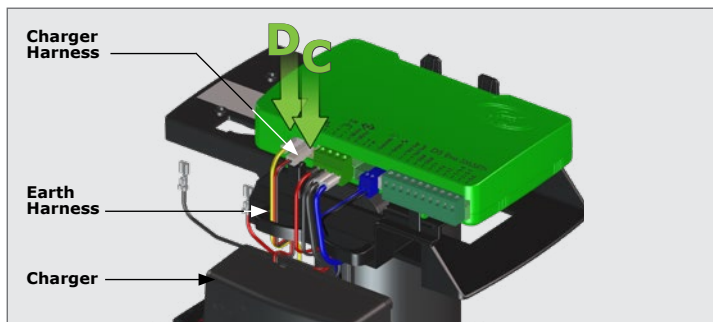


FIGURE 108. D5-EVO SMART+

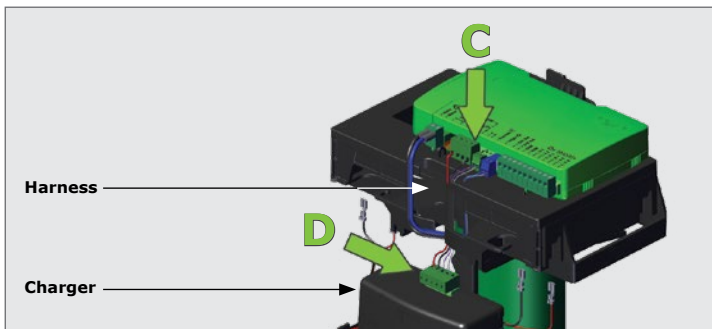


FIGURE 109. D6 SMART+, D10 SMART+, D10 TURBO SMART+ AND D20 SMART+



If the connection is made at Point "C", note that there are two connector blocks that need to be reconnected to the Control Card.

## 7.12 Installing the Origin Sensor and Marker



The Origin Sensor and Marker is an optional extra for the **D10 SMART+**, but is mandatory to use for the **D10 Turbo SMART+**, and the **D20 SMART+** as a safety precaution.

### 7.12.1. Installing the Origin Sensor and Marker

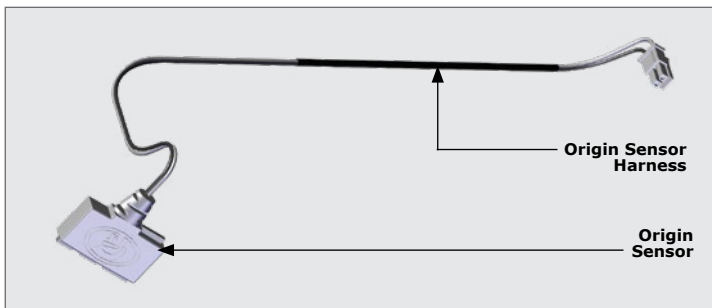


FIGURE 110

Place the Origin Sensor into its dedicated slot found just above the Pinion on the Lower Battery Tray.



Note the orientation of the Origin Sensor.

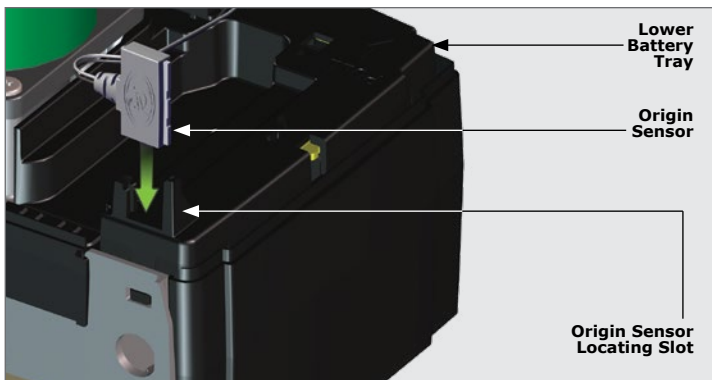


FIGURE 111

Route the Harness around the electric motor to the front of the operator, and through the cable retainers found in front of the Control Card.

Connect the Harness to the white "Origin" Terminal found on the Control Card.

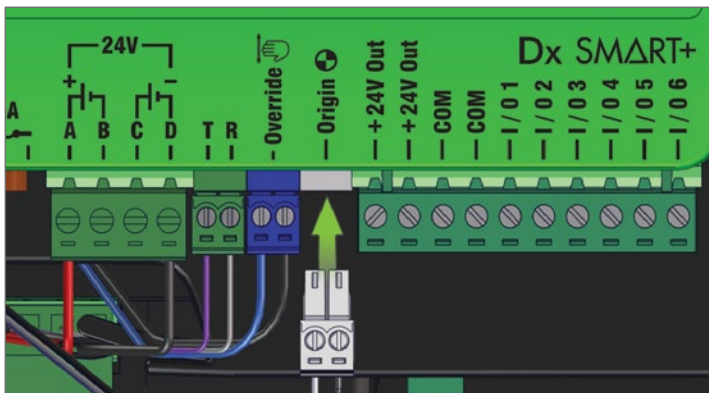


FIGURE 112

### 7.12.2. Installing the Origin Sensor and Marker

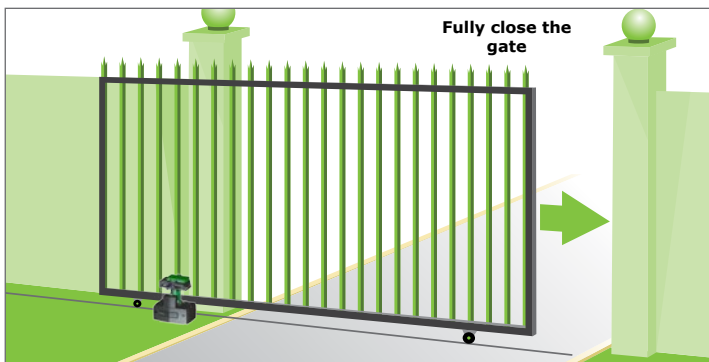


FIGURE 113

Mount the Origin Marker to the rack a minimum of 500mm from the origin sensor. Refer to Figure 114.

It is possible to make the distance between the marker and the sensor much greater than 500mm. However, if using the pedestrian opening facility, although the position of the marker will not affect the width of the pedestrian opening, it is preferable to have the marker mounted inside of the pedestrian opening point.

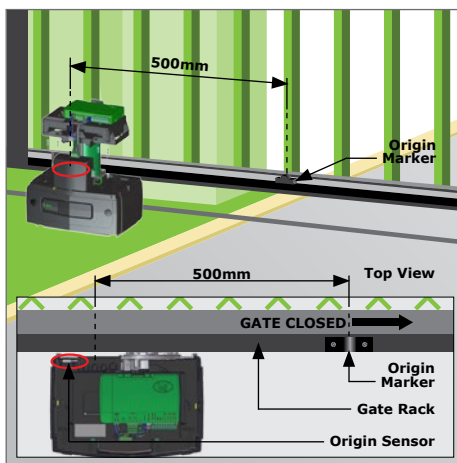


FIGURE 114



Note the orientation of the Origin Marker.

Manually slide the gate open until the origin marker is in line with the origin sensor. Ensure the distance between the face of the marker and front face of the sensor is between 10 and 20mm.

Adjust distance by sliding the Origin Marker along the slotted mounting holes until the specified distance is achieved.

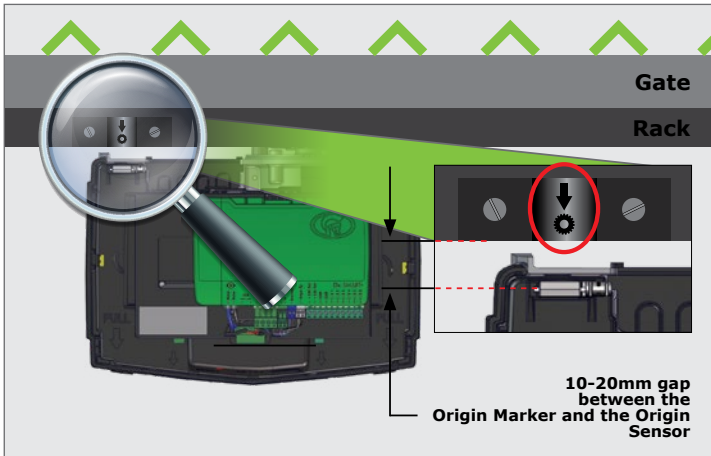


FIGURE 115

### 7.12.3. Mounting the Origin Marker onto the Steel Rack

For Steel Rack, mount the Origin Marker onto the Rack using the bracket provided. Weld the bracket to the Rack.

Bolt the Origin Marker onto the Bracket using the fasteners provided.

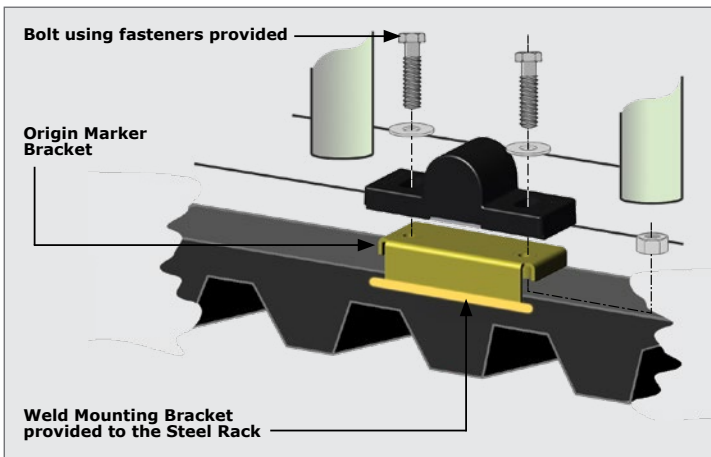


FIGURE 116



Ensure that the Origin Marker is within +/- 10mm of the Origin Sensor in the vertical plane.

## 8. Completing the Installation

### FAST TRACK HYPERLINKS

#### 8.1. Fitting the Battery(ies)

8.1.1. [D3 SMART+, D4 SMART+ and D5-Evo SMART+](#)

8.1.2. [D6 SMART+, D10 SMART+, D10 TURBO SMART+ and D20 SMART+](#) 

8.2. [Wiring and Connecting the Earth and AC Mains Input](#) 

8.3. [D3 SMART+, D4 SMART+ and D5-Evo SMART+ Cable Cover](#) 

8.4. [Accessory Installation and Storage](#) 

### 8.1. Fitting the Battery(ies)

#### 8.1.1. D3 SMART+, D4 SMART+, and D5-Evo SMART+

Gently push the tabs behind the Control Card backwards. This will allow the Control Card to hinge forward.

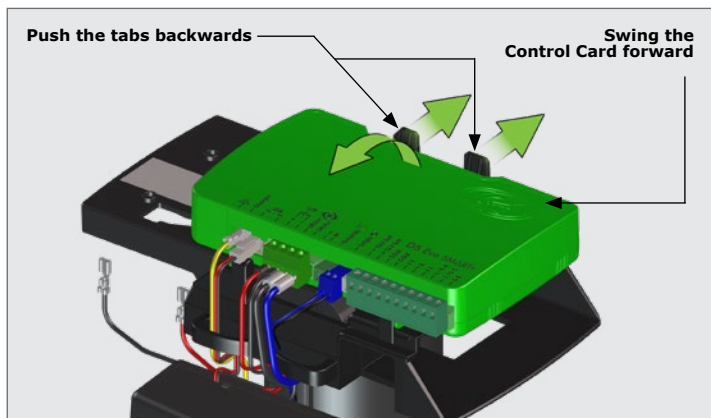


FIGURE 117

Push the two tabs on the Base Tray towards the right. This will allow the Base Tray to hinge up to the right.

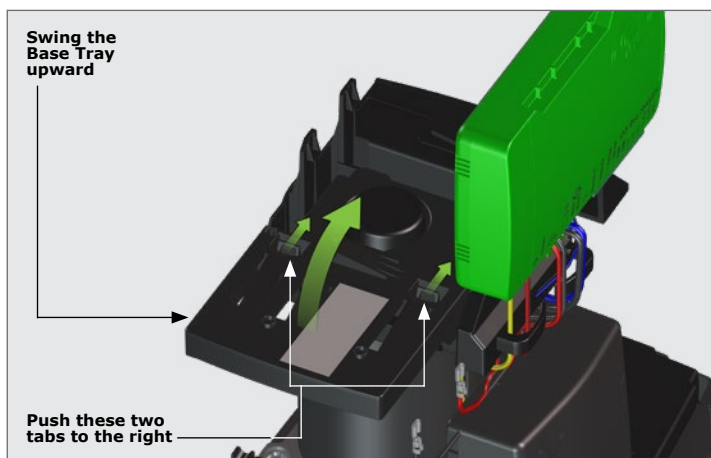


FIGURE 118

Place a Battery into the designated area found on top of the Lower Battery Tray on the left.



Note the orientation of the Battery. Ensure that the Battery Terminals always face the direction of the Charger.

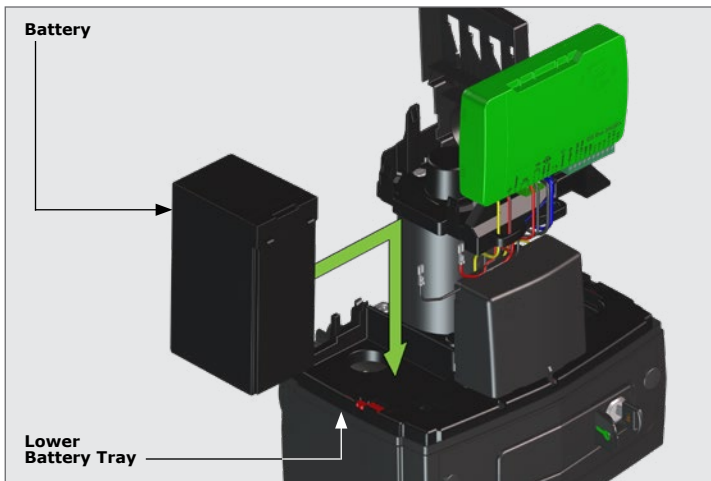


FIGURE 119

Swing the Base Tray back into position over the Battery, and the control card back into position.

Clicks should be heard if this is done correctly.



Failure to properly click the control card and upper assembly into place will result in erratic behaviour of the gate motor.

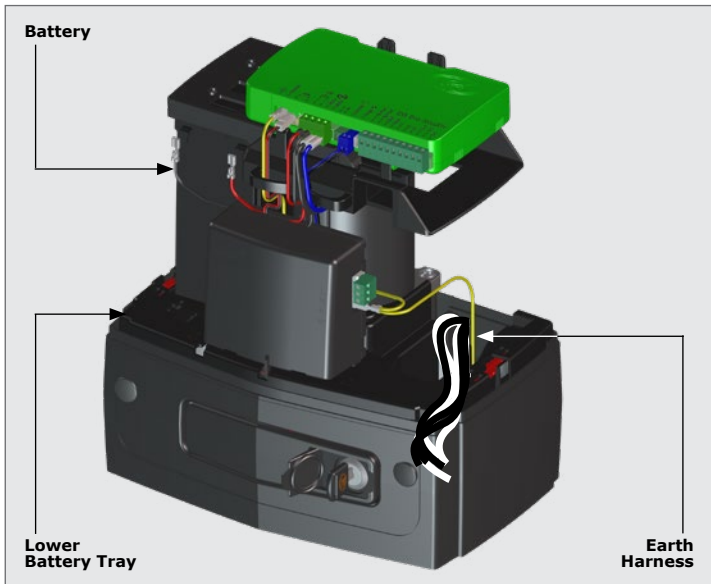


FIGURE 120



Ensure that the Battery connections match the selected Battery terminals RED to RED, BLACK to BLACK.

Route the accessory cables around the back of the Charger and through the cable retainers found in front of the Control Card.

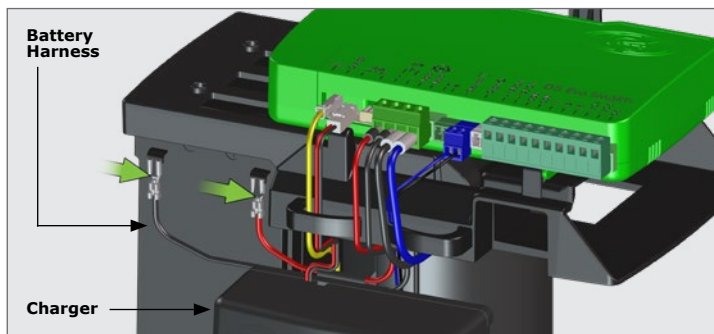


FIGURE 121

### 8.1.2. D6 SMART+, D10 SMART+, D10 TURBO SAMRT and D20 SMART+

Gently push the left tab behind the Control Card backwards. This will allow the entire upper assembly to hinge forward.

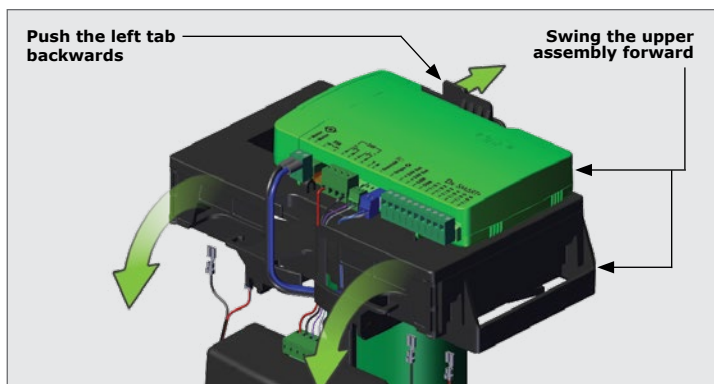


FIGURE 122

Place a Battery into the designated area found on top of the Gearbox Trim on the left. Route the Signal Wires below the Left Battery, and the Power Cables behind the motor and under the Right Battery then place the remaining Battery in its designated area on the right.



Note the orientation of the two Batteries. Ensure that the Battery Terminals always face the direction of the Charger.

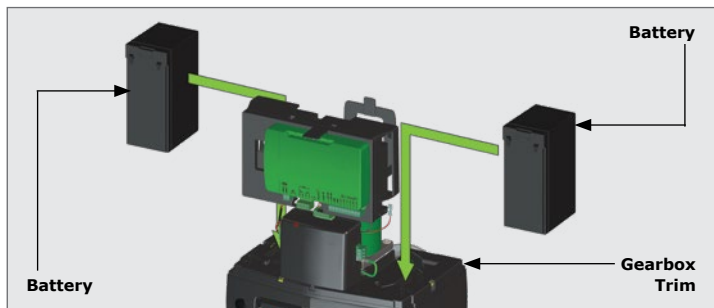


FIGURE 123

Swing the upper assembly back into position over the batteries.  
A click should be heard if this is done correctly.

**!** Failure to properly click the control card and upper assembly into place will result in erratic behaviour of the gate motor.

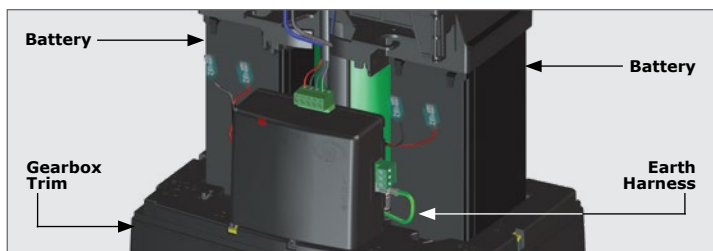


FIGURE 124

Connect both batteries up with the supplied harness, and ensure that it is connected to the left side of the Charger.

Route the accessory cables around the back of the Charger and through the cable retainers found in front of the Control Card.

**!** Ensure that the Battery connections match the selected Battery terminals RED to RED, BLACK to BLACK.

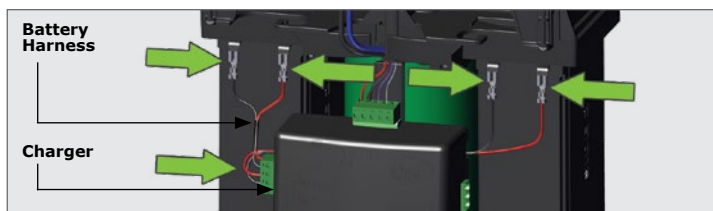


FIGURE 125

## 8.2. Wiring and Connecting the Earth and AC Mains Input

**!** Ensure that the Mains Power is disconnected before proceeding!

Push the Live, Neutral and Earth wires through the smaller end of the Mains Cover, and connect them to the Mains Connector Plug.

**!** Refer to the Right-Hand Side of the Charger to ensure the wires are connected to the Mains Connector Plug in the correct positions.

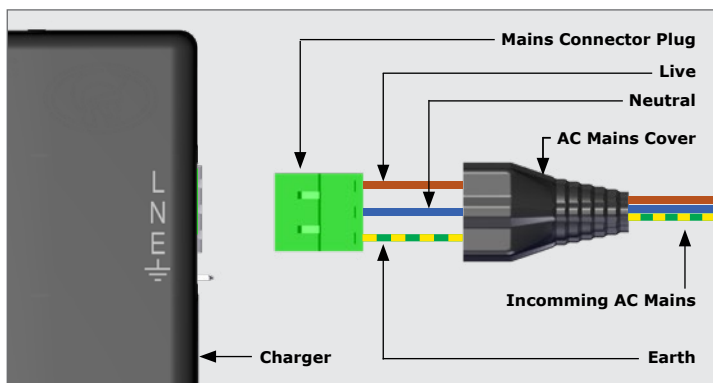


FIGURE 126



Images may vary depending on the **SMART+ Operator** chosen for installation.

Connect the AC Mains Cable Connector into the connector on the right-hand side of the Charger.



Once connected, remember to slide the AC Mains Cover over the AC Mains Connector for added protection.

Connect the Earth Wire to the Earth Tab on the right-hand side of the Charger just below the AC Mains.

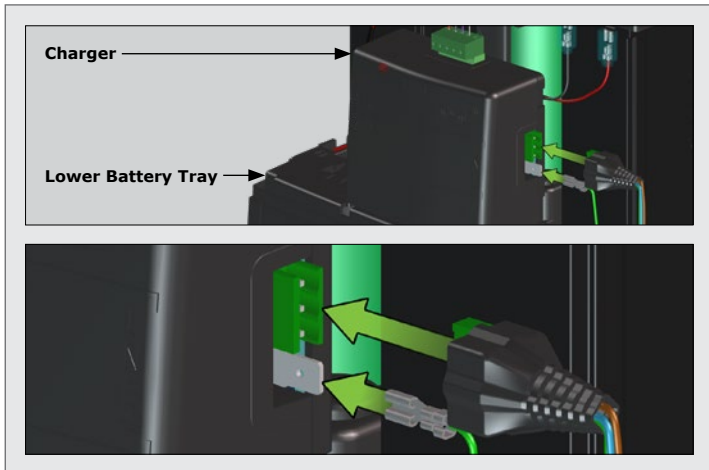


FIGURE 127

### 8.3. D3 SMART+, D4 SMART+, and D5-Evo SMART+ Cable Cover

Place the Cable Cover back into position as shown in Figure 128. Note the orientation of the cover - The arrow must point to the front of the operator.

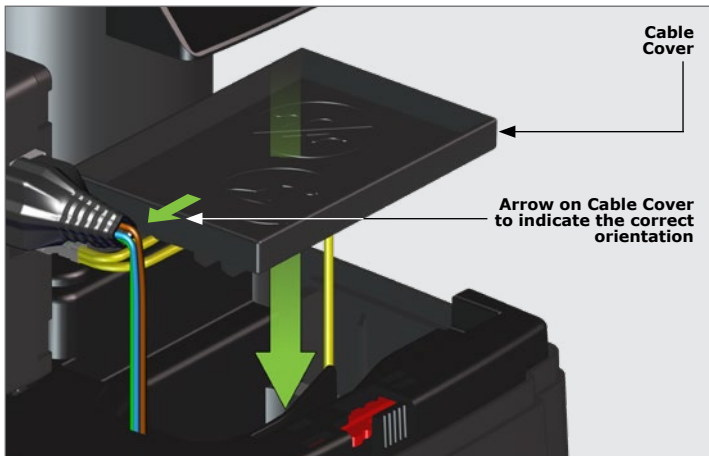


FIGURE 128

## 8.4. Accessory Installation and Storage

There is a dedicated compartment(s) below the **SMART+ Operator Control Card** to conveniently install and store any accessories connected to the Operator.

Opening the two retaining doors of the **D6 SMART+**, **D10 SMART+**, **D10 TURBO SMART+**, and **D20 SMART+**, reveal the storage space for accessory products, such as the **G-ULTRA**, or External Receivers.

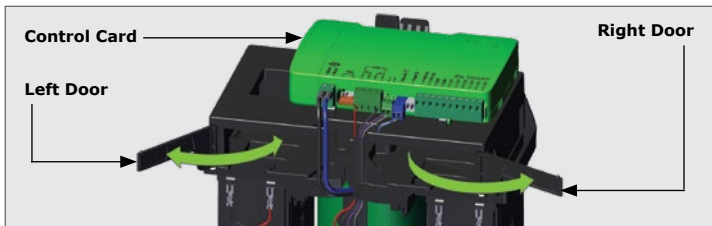


FIGURE 129

Wire the accessory device to the operator, place it into the space provided.

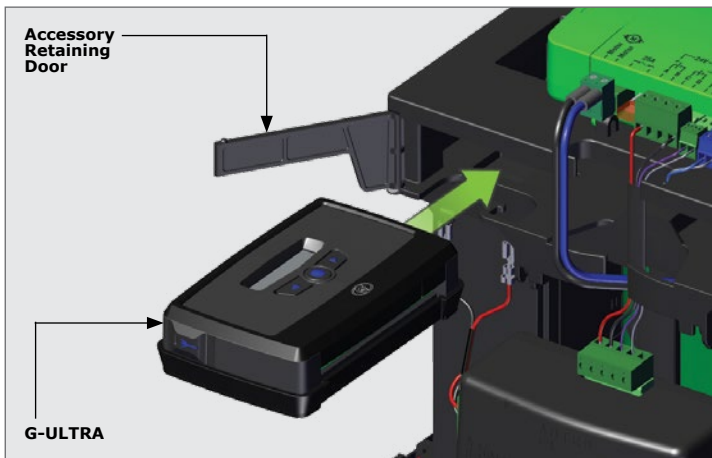


FIGURE 130. D6 SMART+, D10 SMART+, D10 TURBO SMART+, AND D20 SMART+

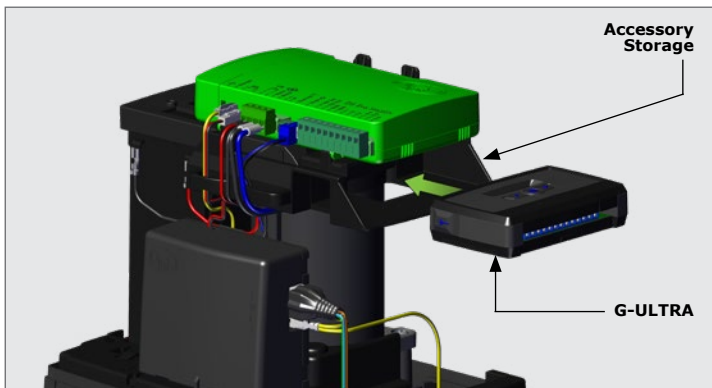




FIGURE 131. D3 SMART+, D4 SMART+, AND D5-EVO SMART+

## 9. Low-voltage Chargers

### FAST TRACK HYPERLINKS

- 9.1. [Isolating Transformer Safety Requirements](#)
- 9.2. [Introduction](#) 
- 9.3. [Low-voltage Charger Technical Specifications](#) 
- 9.4. [Low-voltage Charger Product Identification](#) 

### 9.1. Isolating Transformer Safety Requirements

#### IMPORTANT TRANSFORMER SAFETY INFORMATION



The Low-voltage Charger is not included with this operator.

#### ATTENTION!

To ensure the safety of people and possessions, it is important that you read all of the following instructions. Incorrect installation or incorrect use of the product could cause serious harm.

The Isolation Transformer that supplies the **Low-voltage AC Charger**;

- **MUST** meet all Country Regulatory Standards
  - **MUST** meet all Local Regulatory Requirements
  - **MUST** be a Safety Isolating Transformer
  - **MUST** be Double-wound
  - **MUST** be fitted with a **Thermal Fuse** on the Primary / Input of the Transformer
  - **MUST** be installed according to Country and Local Regulatory Standards
- All installation, repair, and service work to this product must be carried out by a suitably qualified person
  - Do not install the equipment in an explosive atmosphere; the presence of flammable gases or fumes is a serious danger to safety
  - Before attempting any work on the system, turn off electrical power to the Isolating Transformer and disconnect the batteries
  - The Mains power supply of the Isolating Transformer must be fitted with an all-pole switch with contact opening distance of 3mm or greater; use of a hydraulic breaker with all-pole circuit break is recommended
  - Make sure that an earth leakage circuit breaker with a threshold of 30mA is fitted upstream of the system
  - Make sure that the earthing system is correctly constructed and that all metal parts of the system are suitably earthed

#### Isolating Transformer Requirements

	12V Low-voltage Charger		24V Low-voltage Charger	
<b>Output Voltage</b>	15V AC MIN (Loaded) 22V AC MAX (Unloaded/Open circuit)		24V AC MIN (Loaded) 28V AC MAX (Unloaded/Open circuit)	
<b>Output Current</b>	2A MIN (@ 15 V AC = 30VA)		2A MIN (@ 24 V AC = 50VA)	
<b>Transformer Fuse Protection</b>	<b>Type</b>	<b>Rating</b>	<b>Type</b>	<b>Rating</b>
	Thermally Fused	According to VA rating	Thermally Fused	According to VA rating

TABLE 7

## 9.2. Introduction

**Low-voltage AC SMART+ Chargers** are available in both 12V and 24V variants, developed specifically to complement their respective gate operators.

They use low-voltage AC inputs (15-18V AC for 12V systems and 24-28V AC for 24V systems) supplied via an isolation transformer to safely power and charge the batteries of compatible **SMART+ operators**. Both variants are ideal for residential installations.

## 9.3. Low-voltage Charger Technical Specifications

	12V Low-voltage Charger	24V Low-voltage Charger
<b>Input Voltage</b>	Low-voltage 15-18V AC 50/60Hz	Low-voltage 24-28V AC 50/60Hz
<b>Output Voltage</b>	14.4V DC (float) +/- 1%	27.4V DC (float) +/- 1%
<b>Output Current</b>	1.7A +/-5%	

TABLE 8

## 9.4. Low-voltage Charger Product Identification

### 9.4.1. 12V Low-voltage Charger

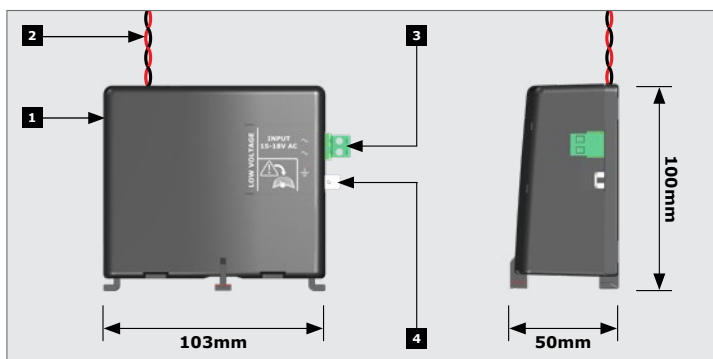


FIGURE 132. 12V LOW-VOLTAGE CHARGER

1. 12V Low-voltage Charger
2. Output
3. 15-18V AC Input Terminals (from transformer)
4. Earth Tab

### 9.4.2. 24V Low-voltage Charger

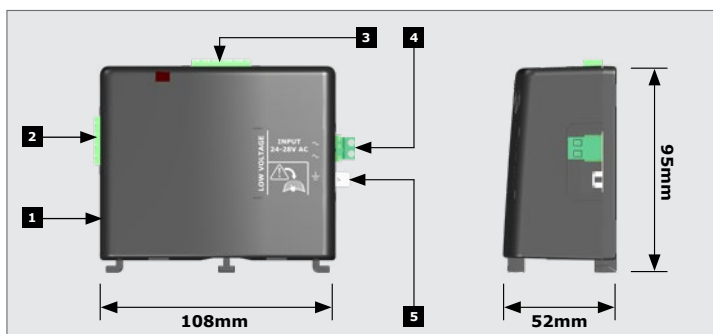


FIGURE 133. 24V LOW-VOLTAGE CHARGER

1. Charger to Batteries Output
2. 24V Low-voltage Charger
3. Charger to Control Card Output
4. 24-28V AC Input Terminals (from transformer)
5. Earth Tab



Wiring for the 12V and 24V Low-voltage Chargers can be found at Section 10.1. "Low-voltage Charger Wiring" 

 [BACK TO SECTION INDEX](#)

 [BACK TO CONTENTS](#)

## 10. Wiring the Controller on Default Settings

### FAST TRACK HYPERLINKS

- [10.1 Low-voltage Charger Wiring](#)
- [10.2 Closing Infrared Beam Wiring \(i5 Infrared Beams\)](#)
- [10.3 Closing Infrared Beam Wiring \(Photon Infrared Beams\)](#)
- [10.4 Wireless Photon Smart beams](#)
- [10.5 External Radio Receiver and Loop Detector Wiring](#)
- [10.6 Solar Panel Wiring](#)
- [10.7 Earth Spike Installation](#)
- [10.8 G-ULTRA Wiring](#)
- [10.9 12-24V Siren Wiring](#)
- [10.10. GLX900 Gatelock Wiring](#)
- [10.11. Maglock Wiring](#)
- [10.12. Synchronisation of two SMART+ Operators](#)
- [10.13. Commissioning the System](#)
- [10.14. Apply Warning Decal](#)

The **D3 SMART+** Control Card's Input terminals are defaulted with the following configuration;

Control Card Terminal	Default Setting
I1	Trigger (TRG)
I2	Pedestrian (PED)

TABLE 9

The **D4 SMART+** Control Card's Input / Output are defaulted with the following configuration;

Control Card Terminal	Default Setting
I/O1	Trigger (TRG)
I/O2	Pedestrian (PED)

TABLE 10

The **D5-Evo SMART+** Control Card's Input / Output terminals are defaulted with the following configuration;

Control Card Terminal	Default Setting	Control Card Terminal	Default Setting
I1	Trigger (TRG)	I/O4	Gate Status
I2	Pedestrian (PED)	I/O5	Unassigned
I3	Infrared Beam Close (IRBC)	O6	Unassigned

TABLE 11

The **Dx SMART+ (24V)** Control Card's Input / Output terminals are defaulted with the following configuration;

Control Card Terminal	Default Setting	Control Card Terminal	Default Setting
I/O1	Trigger (TRG)	I/O4	Gate Status
I/O2	Pedestrian (PED)	I/O5	Unassigned
I/O3	Infrared Beam Close (IRBC)	I/O6	Unassigned

TABLE 12

## 10.1. Low-voltage Charger Wiring

### 10.1.1. 12V Low-voltage Charger - D3 SMART+ and D4 SMART+

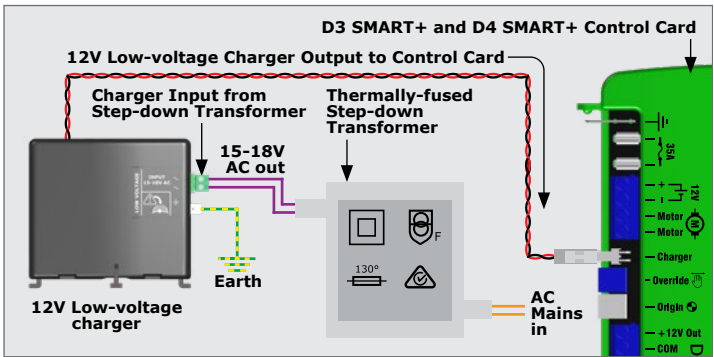


FIGURE 134. 12V LOW-VOLTAGE CHARGER WIRED TO D3/D4 SMART+ CONTROLLER

### 10.1.2. 12V Low-voltage Charger - D5-Evo SMART+

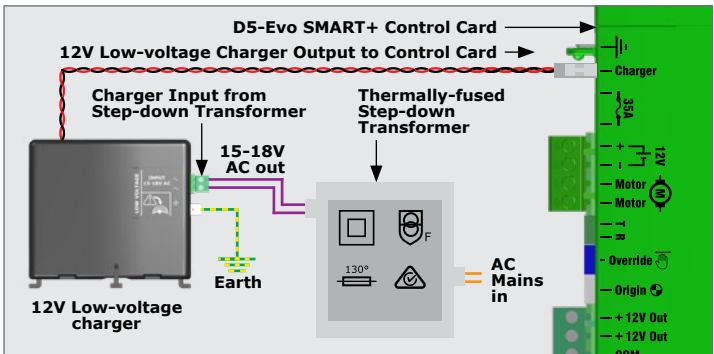


FIGURE 135. 12V LOW-VOLTAGE CHARGER WIRED TO D5-EVO SMART+ CONTROLLER

### 10.1.3. 24V Low-voltage Charger - Dx SMART+

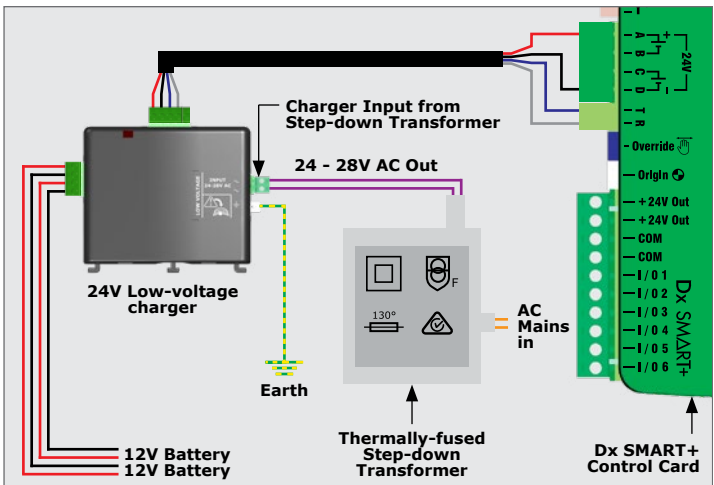


FIGURE 136. 24V LOW-VOLTAGE CHARGER WIRED TO DX SMART+ CONTROLLER

## 10.2. Closing Infrared Beam Wiring (i5 Beams)

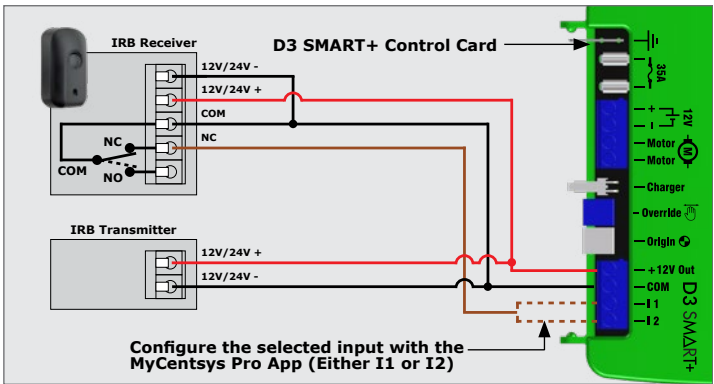


FIGURE 137. I5 TO D3 SMART+ CONTROLLER

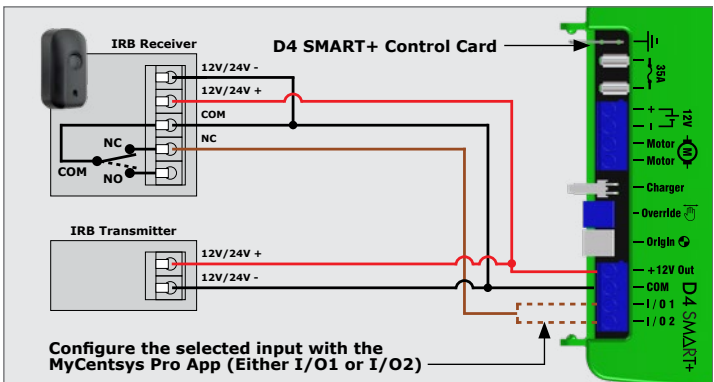


FIGURE 138. I5 TO D4 SMART+ CONTROLLER

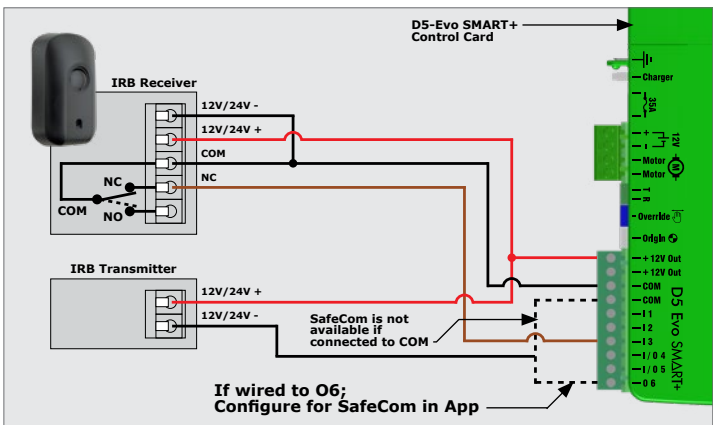


FIGURE 139. I5 TO D5-EVO SMART+ CONTROLLER



Please contact Centurion Systems (Pty) Ltd for directions on wiring Infrared Beams in an opening configuration.

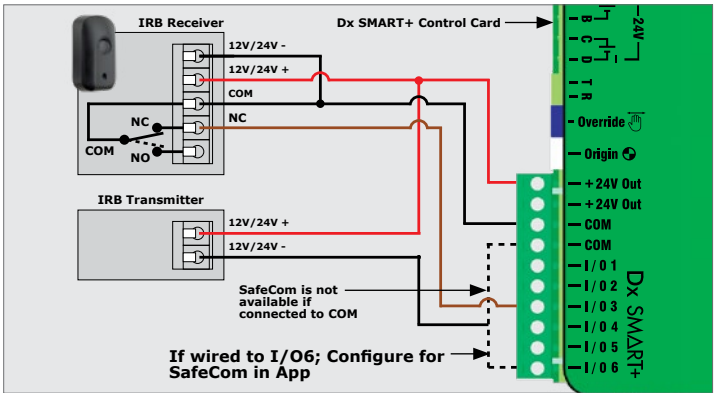


FIGURE 140. I5 TO DX SMART+ CONTROLLER

### 10.3. Closing Infrared Beam Wiring (Photon Beams)

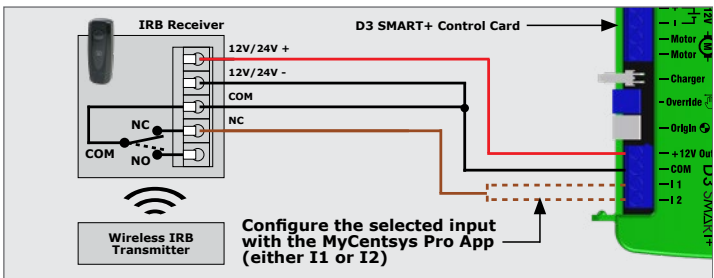


FIGURE 141. PHOTON TO D3 SMART+ CONTROLLER

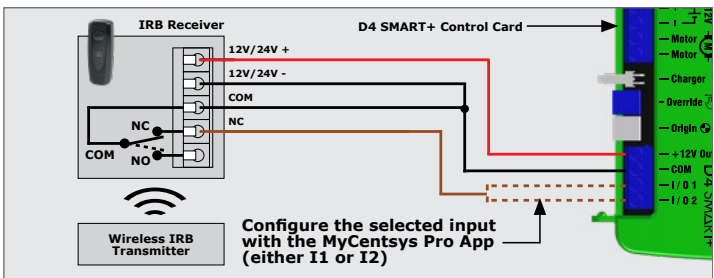


FIGURE 142. PHOTON TO D4 SMART+ CONTROLLER

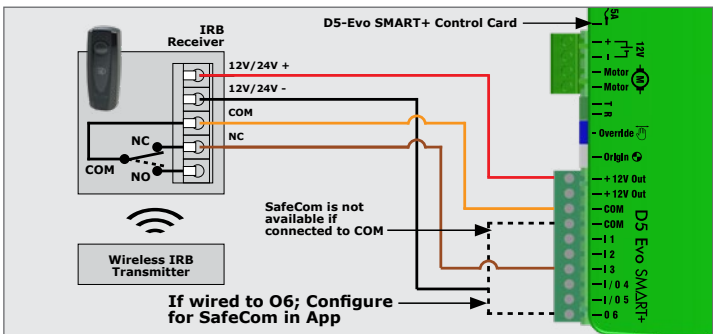


FIGURE 143. PHOTON TO D5-EVO SMART+ CONTROLLER

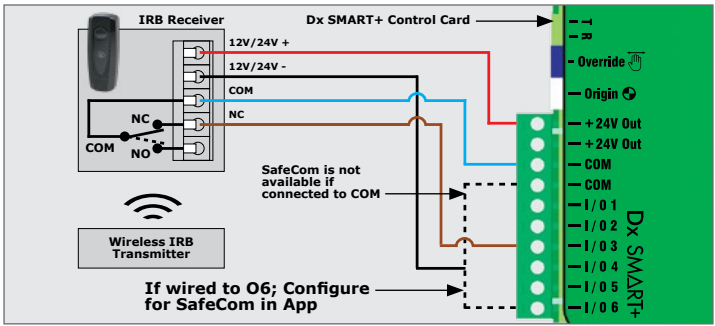


FIGURE 144. PHOTON TO DX SMART+ CONTROLLER

## 10.4. Wireless Photon Smart Beams

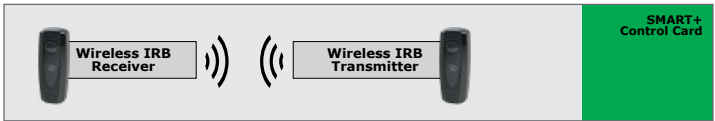


FIGURE 145



Opening or Closing beams can be configured using the MyCentsys Pro mobile application

## 10.5. External Radio Receiver and Loop Detector

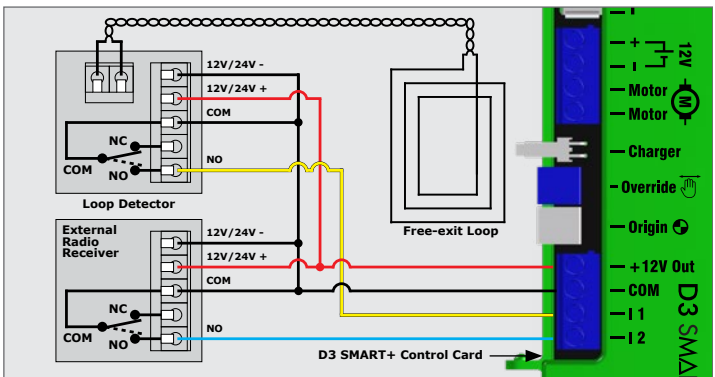


FIGURE 146. EXTERNAL RECEIVER AND LOOP DETECTOR TO D3 SMART+ CONTROLLER

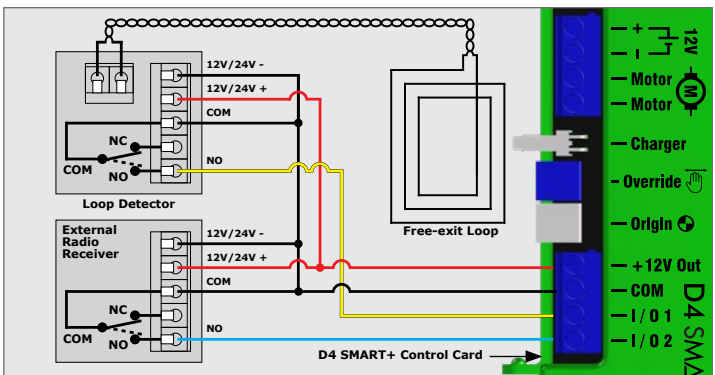


FIGURE 147. EXTERNAL RECEIVER AND LOOP DETECTOR TO D4 SMART+ CONTROLLER

[BACK TO SECTION INDEX](#)

[BACK TO CONTENTS](#)



### 10.6. Solar Panel Wiring

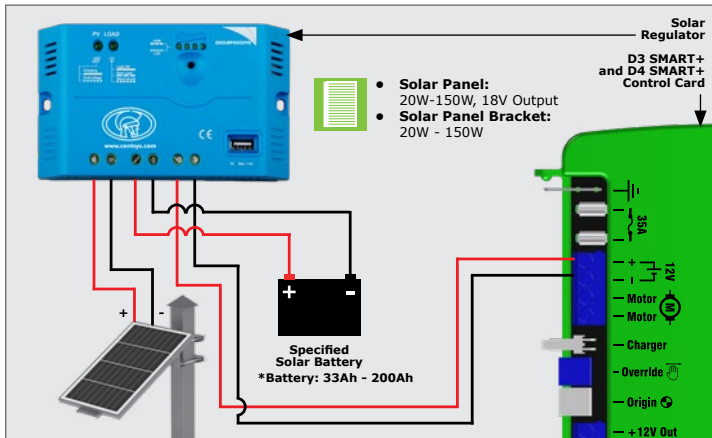


FIGURE 150. SOLAR TO D3 SMART+ AND D4 SMART+ CONTROLLER

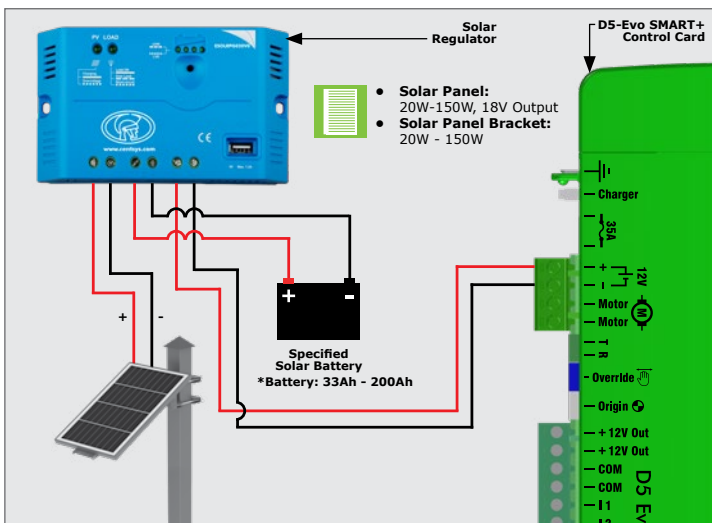


FIGURE 151. SOLAR TO D5-EVO SMART+ CONTROLLER

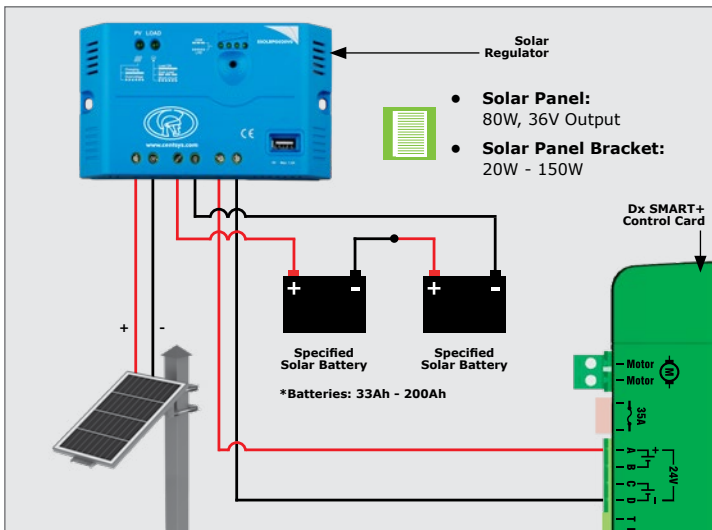


FIGURE 152. SINGLE SOLAR TO DX SMART+ CONTROLLER

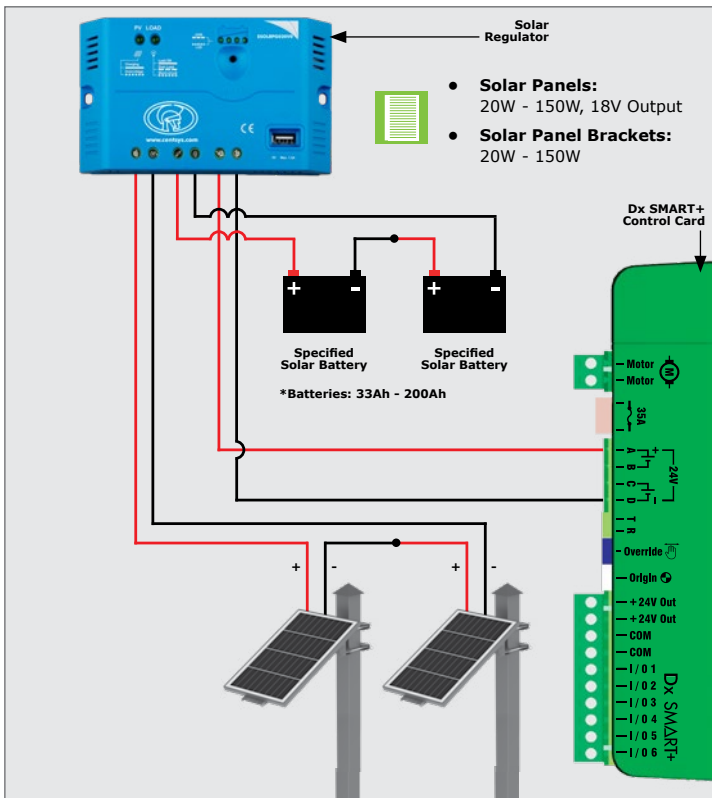


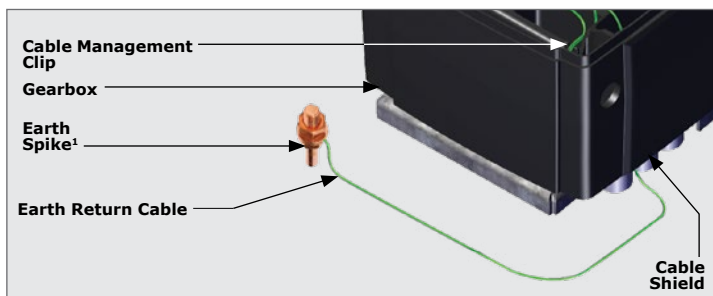
FIGURE 153. DOUBLE SOLAR TO DX SMART+ CONTROLLER

## 10.7. Earth Spike Installation

For further surge protection, an Earth Spike<sup>1</sup> can be installed. Route the earth cable from the Earth Spike around to the back of the **SMART+ Operator**, and under the Gearbox by the Cable Shield. Connect it to the Mounting Bolt on the right of the Gearbox where the Charger Earth is located by means of a Ring Lug.



Utilise the Cable Management Clip to keep the wiring neat and out of the way.



1. Not supplied

FIGURE 154

## 10.8. G-Ultra Wiring



In some installations, GSM devices may cause interference that affects remote range. If reduced range is experienced, try relocating the GSM device to an external wall box.

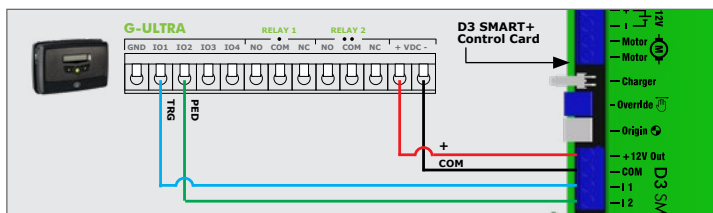


FIGURE 155. G-ULTRA WIRED TO THE D3 SMART+

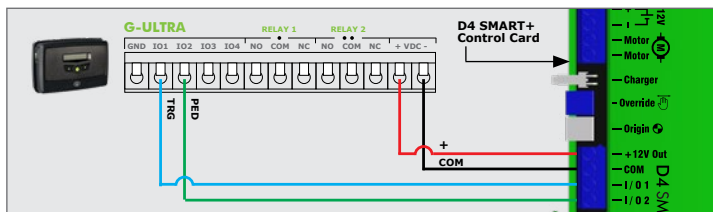


FIGURE 156. G-ULTRA WIRED TO THE D4 SMART+

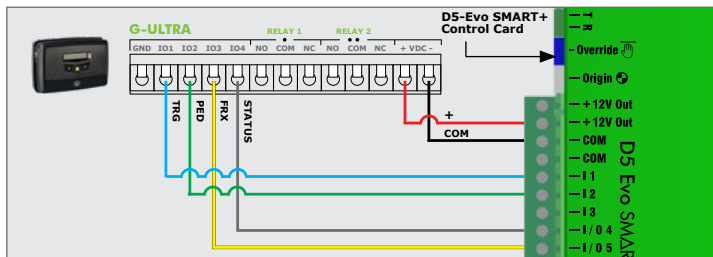


FIGURE 157. G-ULTRA WIRED TO THE D5-EVO SMART+



Settings are configured using the MyCentsys Pro mobile application

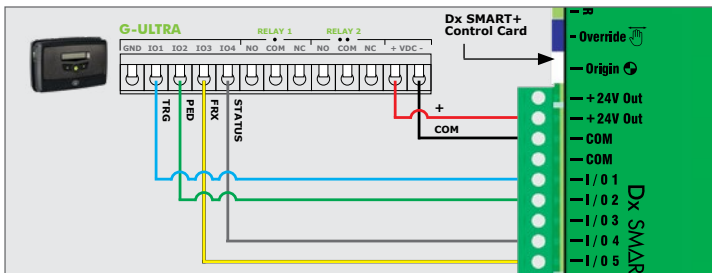


FIGURE 158 . G-ULTRA WIRED TO THE DX SMART+

### 10.9. 12-24V Siren Wiring



The D3 SMART+ does not support the 12-24V Siren

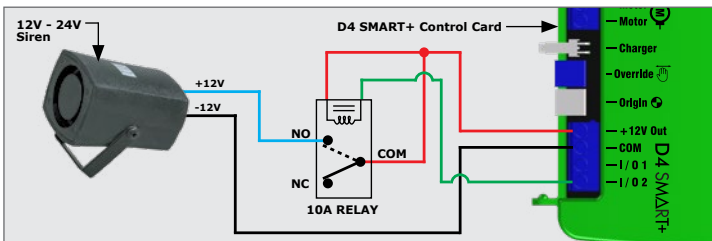


FIGURE 159 . SIREN WIRED TO THE D4 SMART+

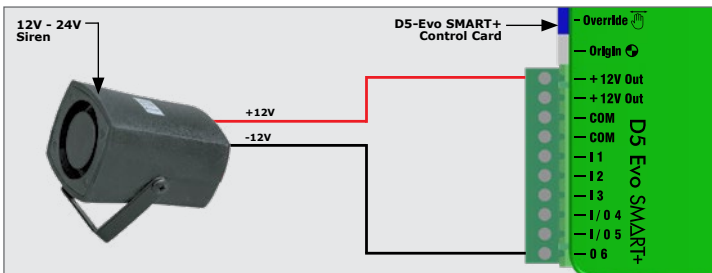
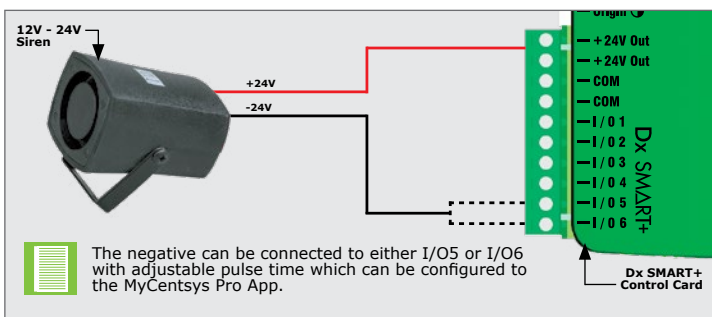


FIGURE 160 . SIREN WIRED TO THE D5-EVO SMART+



The negative can be connected to either I/O5 or I/O6 with adjustable pulse time which can be configured to the MyCentsys Pro App.

FIGURE 161 . SIREN WIRED TO THE DX SMART+



Settings are configured using the MyCentsys Pro mobile application

## 10.10. GLX900 Gatelock Wiring



The **D3 SMART+** does not support the GLX900 Gatelock

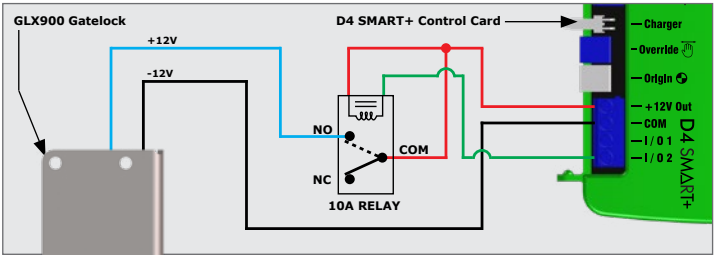


FIGURE 162. GLX900 WIRED TO THE D4 SMART+

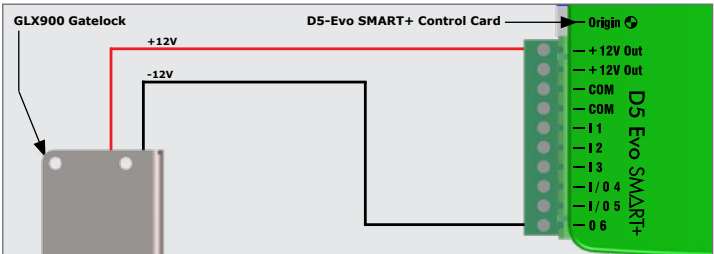


FIGURE 163. GLX900 WIRED TO THE D5-EVO SMART+

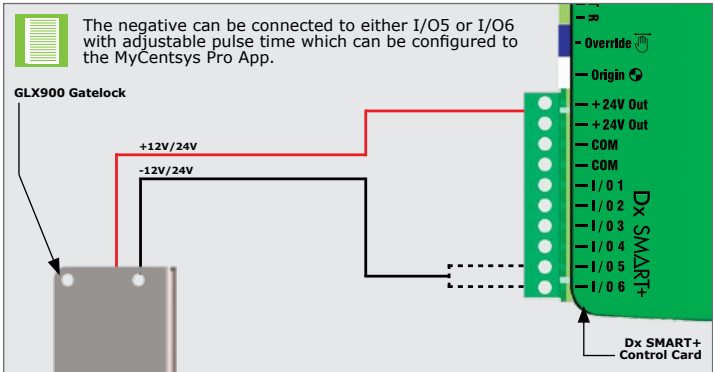


FIGURE 164. GLX900 WIRED TO THE DX SMART+



Settings are configured using the MyCentsys Pro mobile application

### 10.11. Maglock Wiring



The D3 SMART+ does not support Maglocks

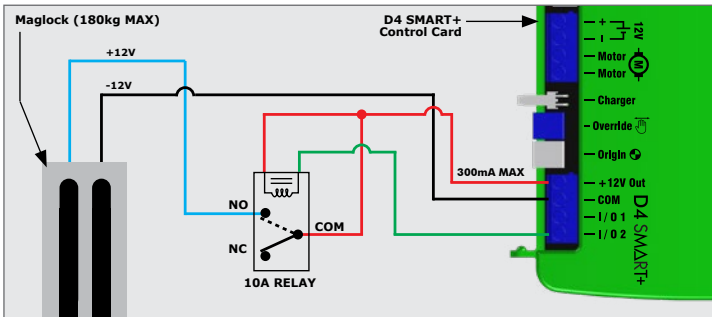


FIGURE 165. MAGLOCK WIRED TO THE D4 SMART+

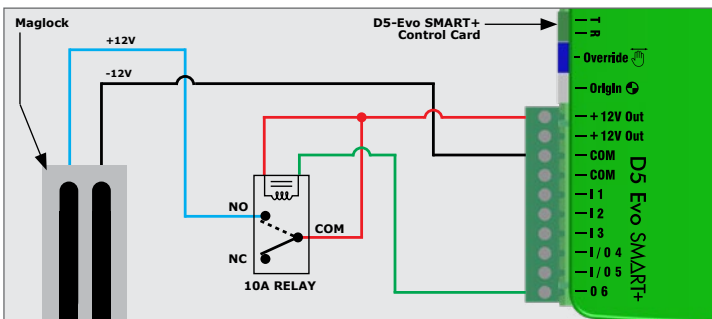


FIGURE 166. MAGLOCK WIRED TO THE D5-EVO SMART+



The negative can be connected to either I/O5 or I/O6 with adjustable pulse time which can be configured to the MyCentsys Pro App.

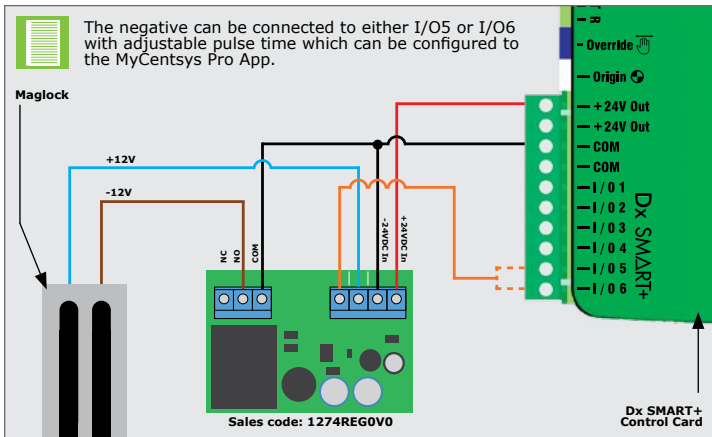


FIGURE 167. MAGLOCK WIRED TO THE DX SMART+



Settings are configured using the MyCentsys Pro mobile application

## 10.12. Synchronisation of Two SMART+ Operators



The **D3 SMART+** does not support Synchronisation

The following diagram illustrates how to connect two **D6 SMART+** controllers so that the operation of the operators is synchronised.

Using the MyCentsys Pro App, configure the settings as follows for the respective controllers;

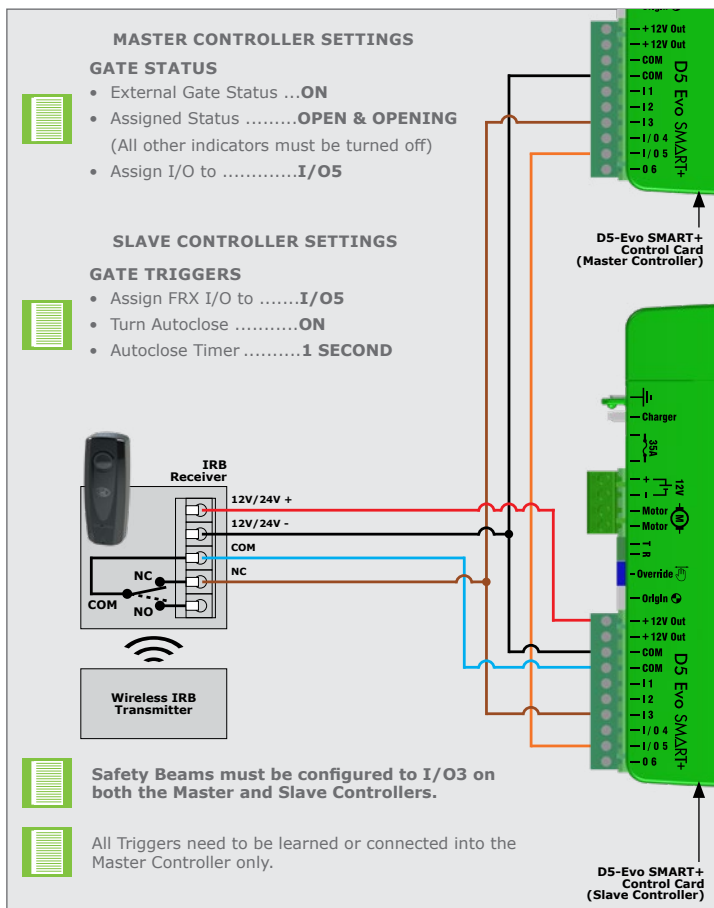


FIGURE 168. SYNCHRONISING TWO D5-EVO SMART+ OPERATORS (12V)

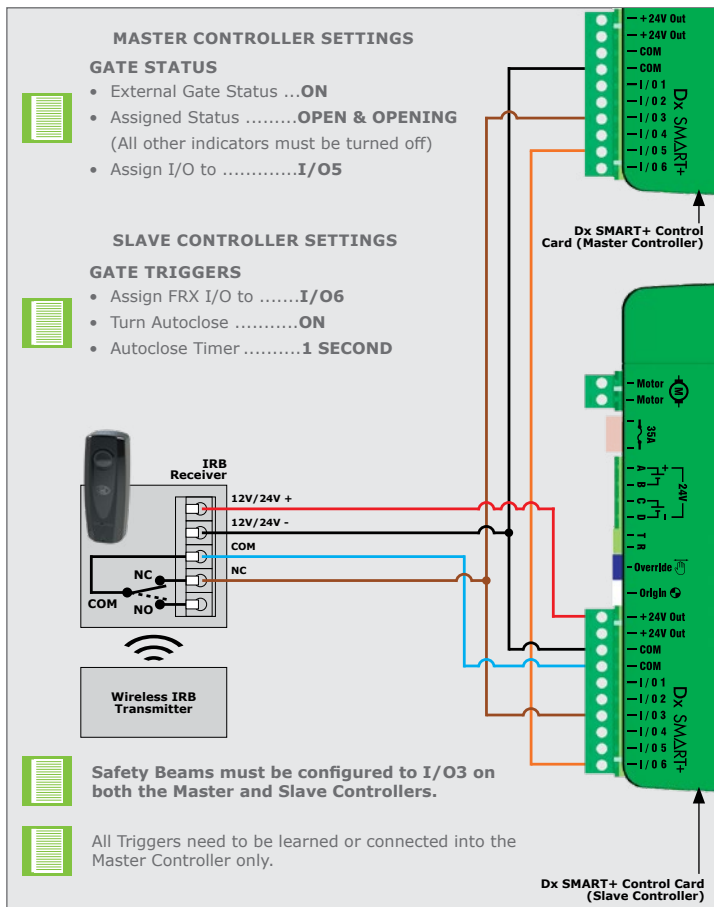


FIGURE 169. SYNCHRONISING TWO DX SMART+ OPERATORS (24V)

### 10.13. Commissioning the System

1. Tap or scan the linked the QR Code or applicable App Store Icon in Figure 170.
2. Select the App Store applicable to the operating system being used, either Apple App Store, Android Google Play Store or the Huawei App Gallery.
3. Download and install the application(s).

**MyCentsys Pro**

**MyCentsys**

**MyCentsys Remote**

Download on the App Store

**Minimum Requirements:**

- BLE-enabled mobile phone
- iPhone 6s and above
- iOS13

EXPLORE IT ON AppGallery

Get it on Google play

**Minimum Requirements:**

- BLE-enabled mobile phone
- Android 8.0. (Oreo)

FIGURE 170

Alternatively, go directly to the app store of the operating system being used, and search for the apps. "MyCentsys Pro", "MyCentsys" and/or "MyCentsys Remote". Download and install the application onto the smartphone.

### 10.13.1. MyCentsys Pro Application

1. Once **MyCentsys Pro** has been installed, open the application.
2. From the list of operators, select the operator that applies to this installation.
3. Connect to the relevant operator.
4. Use the **MyCentsys Pro** app by following the prompts to configure the SMART/SMART+ operator.

### 10.13.2. MyCentsys Application

An intuitive configuration hub for all SMART/SMART+ devices.

**MyCentsys** puts the ultimate in configuration and flexibility at your fingertips.

1. Once installed, open the application.
2. From the list of operators, select the operator that applies to this installation.
3. Connect to the relevant operator.
4. Use the **MyCentsys** App by following the prompts to configure user settings on the SMART/SMART+ Operator:
  - Adding NOVA remotes, MyCentsys Remote Users and Admin Users.
  - Configuring the Wi-Fi settings (SMART+ Only).
  - Configuring ChronoGuard Settings.

### 10.13.3. MyCentsys Remote Application

An intuitive commanding hub for all SMART/SMART+ and ULTRA devices. **MyCentsys Remote** puts the ultimate in control and flexibility at your fingertips.

A fully customisable experience for your compatible access automation solutions.

1. Once installed, launch the application.
2. Register with the relevant details.
3. Select the "+ SMART" / "+ SMART+". (BLE Only)
  - If the Operator is connected to Wi-Fi (SMART+ Only) and the user is added as a **MyCentsys Remote** user, the operator will appear automatically on the list of operators in the **MyCentsys Remote** App.
4. From the list of operators, select the operator that applies to this installation.
5. Wait for the "Device Added" message after tapping on the selected operator.
6. Select the operator on the home screen to view all available triggers and device status.

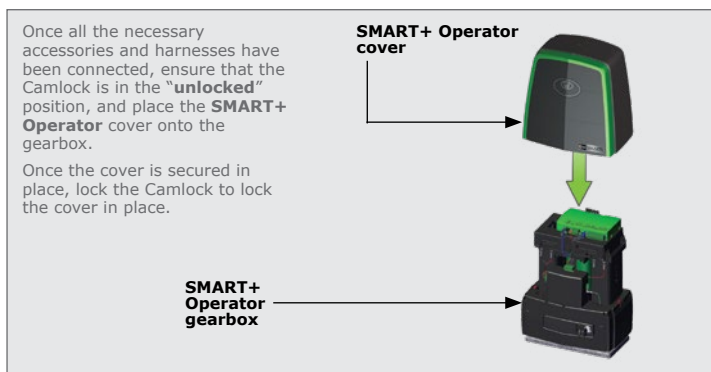


FIGURE 171

## 10.14. Applying the Warning Label

Apply the supplied warning decals to the gate as indicated on the reverse side of the decal.



FIGURE 172

## 11. General Maintenance

### 11.1. Gate Maintenance

Description	Frequency	Corrective Action
Ensure that the gate track is clear of debris at all times	Daily	Clean around the gate and gate operator. Consider installing gate brooms on the bottom of the gate
Ensure that the endstops are sturdy and secure	Every 3 months	If the endstops are damaged or loose, contact an installer to replace
Check that the rack is securely mounted to the gate over its full length	Every 3 months	Contact installer
Contact an installer to inspect and verify that all safety equipment, e.g. safety beams, is functioning correctly	Every 6 months	N/A
Ensure that the gate moves smoothly when in Manual Override. Check wheels and guide-rollers for signs of wear	Every 6 months	Place the motor in Manual Override and manually open and close the gate. If the wheels and/or guide-rollers are excessively worn, contact an installer to replace
Check the track for damage or corrosion	Every 6 months	If the track is damaged, contact an installer to replace
If pedestrian gate / emergency gate is fitted within the main gate, ensure that the lock operates smoothly	Every 6 months	Dry lubricate if necessary (graphite)

TABLE 13

### 11.2. SMART+ Operator Maintenance



**Before performing any maintenance, ensure that the SMART+ Operator is isolated, turn off AC Mains and disconnect the batteries!**


Description	Frequency	Corrective Action
Check for insect infestations	Every 3 months	Clean and remove any nests that are settling in and around the motor and Control Card  Insert a moth ball, which may help to repel insects, at the bottom of the gearbox
Check that the M10 half-nuts are tight on the foundation plate bolts	Every 6 months	Torque setting 20Nm
Check that there is no sand build-up inside the unit	Every 6 months	Remove batteries and lower battery tray and clear out the sand build-up
Check pinion and rack engagement	Every 6 months	If the mesh is too loose or the rack is riding on the pinion, contact an installer to correct
Check the condition of the pinion	Every 6 months	If the pinion is excessively worn, contact an installer to replace
Check the condition of the override cam lock	Every 6 months	Dry lubricate if necessary (graphite)
If used, check the condition of the theft-deterrent cage	Every 6 months	Ensure that the device is serving its purpose
If used, check the condition of the theft-deterrent cage lock and that it operates	Every 6 months	Dry lubricate if necessary (graphite)

TABLE 14

## 12. PRODUCT ANCILLARIES



### Solar Supply Solution

Alternative means of powering the system - consult your CENTURION dealer



### Photon SMART Safety Beams

Fully-wireless infrared beams. Always recommended on any SMART automated installation



### Theft-Deterrent Cage & Padlock

Patented design provides excellent deterrence against theft, tampering and vandalism



### G-ULTRA

The ultimate GSM solution for monitoring and activating the operator via your mobile phone



### G-SPEAK ULTRA

Answer your intercom from anywhere for maximum security and convenience - powered by 4G technology



### Gate Stations

Communication hub for the G-SPEAK ULTRA GSM intercom - available in both durable plastic and stylish and strong metal enclosures



### 12V-24V SMART Sirens

Both wired and wireless SMART Sirens designed to integrate with existing SMART and SMART+ gate and garage door operators (Not applicable to D3 SMART/SMART+)



### SMART PowerPack

Power unwavering gate performance for busy sites. Run your gate directly from mains. Optional battery backup for added flexibility (Not Applicable to D3 and D5-EVO SMART+)



### Steel, Nylon RAZ or Nylon Angle Rack

A variety of rack available in different lengths, for different strengths



### Low-Voltage Chargers

Enjoy a safe, reliable and cost-effective way to power your gate operator and enjoy outstanding performance and exceptional flexibility



### SMARTGUARD or SMARTGUARDair Keypad

Cost-effective and versatile wired and wireless keypad, allowing access to users with a customised code



### FLUX SA Loop Detector

Allows free-exit of vehicles from the property - requires ground loop to be fitted

## 13. Installation Handover Checklist

The final step in delivering a comprehensive service to the customer is to ensure a smooth handover of the site. Proper training for users is crucial for the safe and effective operation of the automated gate system. Follow this guide to provide thorough training to users: Never assume the user knows how to safely operate an automated gate.

### 13.1. Manual Release Mechanism

- Demonstrate how to operate the Manual Override mechanism (Regular and latching). Emphasise the importance of understanding this mechanism for emergencies
- Demonstrate how to remove the theft-deterrent cage (Optional, but recommended)
- Hand over the keys to the client

### 13.2. Obstruction Detection and Safety Features:

- Demonstrate the functioning of obstruction detection and other safety features
- Demonstrate the functioning of the Safety Beams and any additional features such as PIRAC, Break-in Alarm, Ambush Alarm and Tamper Alarm (Optional, but recommended)
- Ensure that users are aware of the system's capability to respond to potential hazards; a useful tool for this purpose will be the operator overview and notifications in the **MyCentsys Remote** App or the **MyCentsys User** App

### 13.3. Operator Features and Benefits

- Provide a detailed overview of all features that have been configured, including the accessories
- Highlight the role of each feature configured in enhancing the functionality and safety of the system
- Assist the client in setting up their **MyCentsys Remote** App and explain how the **MyCentsys Remote** App performs actions and delivers notifications
- Assist the client in setting up their **MyCentsys User** App and explain how to:
  - Add/Remove NOVA remotes
  - Add/Remove MyCentsys Remote Users
  - Add/Remove Admin Users (Ensure that the end-user is set as an Admin user on their operator)
  - Wi-Fi Configuration (SMART+ Only)
- Explain how the NOVA remotes work and which button performs which function
- Demonstrate how the courtesy/warning light works (Optional)
- Highlight the functionality of the tamper alarm (optional, but recommended)

### 13.4. Safety Considerations:

Stress the responsibility of users in passing on safety knowledge to others. Communicate the following safety considerations:

- Do not activate the gate unless the area of travel is clear
- Avoid crossing the path of a moving gate
- Children should not operate or play with gate controls
- Maintain a safe distance from moving parts
- Show the customer that all the necessary safety mechanisms have been installed on the physical gate (i.e. end-stops, catch-bracket, guide-rollers, etc.) to ensure the safe operation of the physical gate
- Secure all easily-accessible gate operator controls to prevent unauthorised use of the gate

**13.5. Gate Operator Controls**

- Instruct users to secure gate operator controls to prevent unauthorised use
- Emphasise the importance of controlling access to the gate system

**13.6. Maintenance and Checks**

- Highlight the need for regular maintenance to ensure optimal system performance
  - Run through parts that need to be maintained and checked regularly (i.e. track, wheels, end stops, guide-rollers, catch-brackets, rack, battery, etc.)
  - Operator health via the **MyCentsys User App**
  - Ensure that there is no insect ingress present in the operator
- Check if the obstruction detection system and safety devices for correct operation are in working order once a month
- Make the client aware that the gearbox is pre-filled with oil and that the SMART/SMART+ Operator does not require any routine maintenance
- Indicate that no additional lubricants are required between the rack and pinion

**13.7. Authorised Service:**

- Communicate that all repair and service work must be performed by a qualified Centurion Systems professional
- Reinforce the importance of adhering to the guidelines for system integrity and warranty

**13.8. Product Use and Liability:**

- Emphasise that the product is designed for a specific use, and any other use may compromise the safety and warranty of the product
- Make users aware of their responsibility in using the product as documented

**13.9. Centurion Systems (Pty) Ltd Disclaimer:**

- Communicate Centurion Systems' disclaimer about product liability
- Centurion Systems (Pty) Ltd does not accept any liability caused by improper use of the product, or for use other than that for which the automated system was designed. Ensure that the customer has the User Guide and that you have completed the installation details in the back of the User Guide.
- Reinforce the importance of proper use to avoid any potential dangers
- Remember, a well-informed user is a key factor in maintaining the safety and longevity of the automated gate system. Thank you for your commitment to delivering excellence in service!

**13.10. MyCentsys Pro, MyCentsys Remote and MyCentsys User**

- The applications have been created with security in mind; if the user has security concerns, the following can be highlighted;
- Any new connection to the operator with the **MyCentsys Pro** and/or **MyCentsys User** App needs to be authorised by opening and closing the manual override. If a phone number has been added as an admin user, the user can connect without authorisation as the user is verified to connect to the operator. This will ensure that any would-be intruder can't access the programming to open the gate
- **MyCentsys Remote** users can only activate the operator if their number has been added as a **MyCentsys Remote** user. If the mobile number of the user has not been added, no connection can take place. This will ensure that any would-be intruder can't access the activations to open the gate

## 14. Warranty Information



You can register your product(s) online at [www.centsys.com](http://www.centsys.com), which will assist you in keeping a record of your date of purchase or installation, serial numbers, etc.

All of our products are manufactured with extreme care, thoroughly inspected and tested.

The goods supplied by us shall be subject to the provisions of sections 55 to 57 of the Consumer Protection Act (68/2008) except where the provisions of the warranty contained in our product documentation are more favourable to the purchaser. Subject to the warranty contained in our product documentation, if applicable, our products are warranted for a period of twenty-four months after delivery. However, it is expressly noted that batteries carry a six month warranty due to the nature of these products being such that they are subject to possible misuse. Please note that warranties will be honoured on a carry-in basis; in other words, the product in question must be taken in to one of our branches, or to the authorised reseller that the product was purchased from, for assessment and, if necessary, repair. For equipment not of our manufacture, the warranty as supplied by the original manufacturer will apply if such warranty is more favourable to the purchaser than the relevant provisions of the Consumer Protection Act (Act 68/2008 of South Africa), or any other applicable law as so required in different countries in which the product was sold. Such warranty is valid only once full payment has been received for such goods.

### Australian customers:

















Our goods come with guarantees that cannot be excluded under the Australian Consumer Law. You are entitled to a replacement or refund for a major failure and compensation for any other reasonably foreseeable loss or damage. You are also entitled to have the goods repaired or replaced if the goods fail to be of acceptable quality and the failure does not amount to a major failure

### Any warranty may be voidable on any equipment which:

1. Has not been installed in accordance with the installation instructions provided.
2. Has been subject to misuse or which has been used for any purpose other than that designed for by the manufacturers.
3. Has damage caused as a result of handling during transit, atmospheric conditions (including lightning), corrosion of metal parts, insect infestation, power surges or other forces outside of the control of the manufacturer.
4. Has been repaired by any workshop and / or person NOT previously authorised by the manufacturer.
5. Has been repaired with components not previously tested, passed or authorised by Centurion Systems (Pty) Ltd, South Africa or one of its subsidiary companies.



### Connect with us on:

-  [@CenturionSystemsRSA](#) 
-  [@Centurion.Systems](#) 
-  [@Centurion.Systems](#) 
-  [@AskCenturion](#) 
-  [@Centurion-Systems](#) 
-  [@Centurion.Systems](#) 
-  [@CenturionSystems](#) 
-  [Centurion-Systems](#) 

Subscribe to the newsletter: [www.centsys.com/subscribe](http://www.centsys.com/subscribe) 

### WhatsApp - Technical Support

South Africa: **+27 (0)83 650 4010** 

International: **+27 (0)83 650 4244** 

**Monday to Friday: from 08h00 to 16h30 (GMT+2)**

**Saturday: from 08h00 to 14h00 (GMT+2)**

For more troubleshooting tips, visit our Knowledge Base at  
**CENTSYS KNOWLEDGE BASE**   
where you can find answers to common issues and detailed guides

**E&OE Centurion Systems (Pty) Ltd reserves the right to change any product without prior notice**  
All product and brand names in this document that are accompanied by the ® symbol are registered trademarks  
in South Africa and/or other countries, in favour of Centurion Systems (Pty) Ltd, South Africa.

The CENTURION and CENTSYS logos, all product and brand names in this document that are accompanied by the TM symbol  
are trademarks of Centurion Systems (Pty) Ltd, in South Africa and other territories; all rights are reserved.  
We invite you to contact us for further details.



Doc number: 1401.D.01.0029\_23022026

[www.centsys.com](http://www.centsys.com)