

SDO5 SMART+ INSTALLATION MANUAL

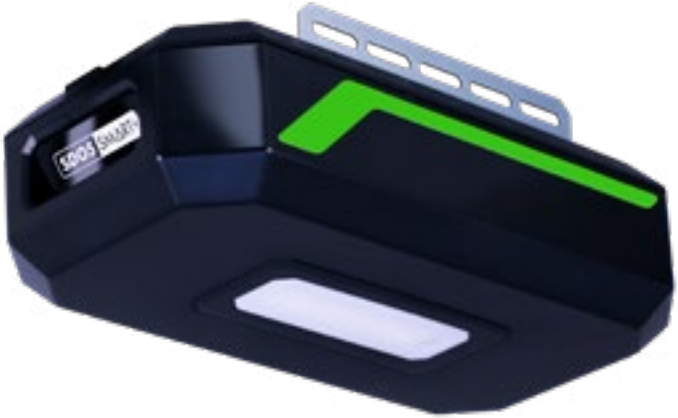

SDO5 SMART+

 **Wi-Fi**



Company Profile



1986

1990

1995

1999

Today

**In-house
R&D
development
team**

**Manufactures to
international
quality standard
ISO 9001:2015**



**After-sales
multi-language
Technical Support**

**100%
testing of
products**

**Sales and technical support to Africa, Europe, Asia,
the Americas, Australia and the Pacific**

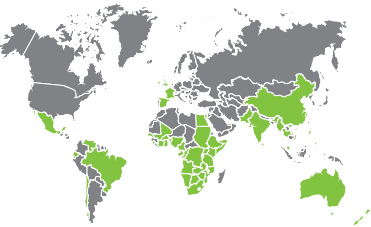

**Technical Support
Operating Times**

Monday to Friday
08h00 to 16h30 GMT+2,











Saturdays
08h00 to 14h00 GMT+2

Centurion Systems (Pty) Ltd reserves the right to make changes to the product described in this manual without notice and without obligation to notify any persons of any such revisions or changes. Additionally, **Centurion Systems (Pty) Ltd** makes no representations or warranties with respect to this manual. No part of this document may be copied, stored in a retrieval system or transmitted in any form or by any means electronic, mechanical, optical or photographic, without the express prior written consent of **Centurion Systems (Pty) Ltd**.



Contents

CONTENTS

	1. INTRODUCTION	PAGE 4
	1.1. Important Safety Information	
	1.2. Safe Disposal of Batteries	
	2. PRODUCT SPECIFICATIONS	PAGE 7
	2.1. Physical Dimensions	
	2.2. Technical Specifications	
	2.3. Maximum Door Size	
	2.4. Fuse Protection	
	3. PRODUCT IDENTIFICATION	PAGE 9
	3.1. Fasteners List and Spares	
	4. REQUIRED TOOLS AND EQUIPMENT	PAGE 10
	5. PREPARATION OF SITE	PAGE 11
	6. OPERATOR INSTALLATION	PAGE 12
	6.1. Assembly Instructions	
	6.2. Installation Instructions	
	6.2.1. Sectional Doors	
	6.2.2. Tip up Doors	
	6.3. Retro-fit Installations	
	6.4. Engaging and Disengaging the SDO5 SMART+	
	6.5. Emergency Lock functionality	
	6.6. Positioning the Opening and Closing Limit Stoppers	
	6.7. The Wireless Wall Switch	
	6.8. Safety Beams	
	6.9. Connecting to a Power Supply	
	6.10. Battery Backup	
	6.10.1. Removing The SDO5 SMART+ Cover	
	6.10.2. Installation of the Battery Kit	
	7. ELECTRICAL SETUP OF ACCESSORIES	PAGE 46
	8. COMMISSIONING THE SYSTEM	PAGE 48
	9. PRODUCT ANCILLARIES	PAGE 49
	10. INSTALLATION HANDOVER CHECKLIST	PAGE 50
	11. WARRANTY INFORMATION	PAGE 52

Icons used in this manual



This icon indicates tips and other information that could be useful during the installation.



This icon denotes variations and other aspects that should be considered during installation.



This icon indicates warning, caution or attention! Please take special note of critical aspects that MUST be adhered to in order to prevent injury.



This icon indicates a clickable hyperlink.

1. Introduction

FAST TRACK HYPERLINKS

1. INTRODUCTION

1.1. Important Safety Information

1.2. Safe Disposal of Batteries

The **SD05 SMART+** has been designed to automate domestic garage doors safely, quietly and reliably. The product's belt-driven system allows for whisper-quiet operation, while reliable mains driven (with optional battery backup) technology ensures that the **SD05 SMART+** will continue working even during lengthy power outages.

In addition, the **SD05 SMART+**'s built-in collision sensing circuitry makes it a very safe automation solution. Kits are available for both Sectional and Tip up garage doors.

Advanced features of the **SD05 SMART+** logic controller include:

- Lightning fast wireless setup of garage door limits and configuration of setting from your smartphone
- Instant access to advanced diagnostics and monitoring of system health
- Door service monitor lets you know when its time to service your door
- Built-in tamper sensor lets you know when the door or operator is being tampered with
- Fail-safe collision detection and auto-reverse (adjustable sensitivity)
- Smooth, adjustable short and long stop
- Tip-up and Sectional modes available
- Selectable, adjustable Auto-close
- Two configurable I/O channels and one input
- Wi-Fi connectivity LED to indicate connectivity
- On-board NOVA code-hopping radio receiver with full channel-mapping capability (limited to 30 4-button remotes)

1.1. Important Safety Information



WARNING! Important safety instructions

To ensure the safety of people and possessions, it is important that you read all the following instructions.

Follow all instructions since incorrect installation can lead to severe injury. Incorrect installation or incorrect use of the product could cause serious harm to people and / or property.

The installer, being either professional or DIY, is the last person on the site who can ensure that the operator is safely installed, and that the whole system can be operated safely.

Warnings for the installer

CAREFULLY READ AND FOLLOW ALL INSTRUCTIONS before beginning to install the product.

- The installation of your new **SD05 SMART+** must be carried out by a technically qualified or licensed person. Attempting to install or repair the **SD05 SMART+** without suitable technical qualification may result in severe personal injury, death and / or property damage
- Before installing the drive, check that the door is in good mechanical condition, correctly balanced and opens and closes properly. The **SD05 SMART+** must only be installed on a properly-balanced, well-functioning garage door. The garage door is deemed to be well-balanced and aligned if it:
 - Requires an equivalent amount of applied force to either manually open or close. The applied force should not exceed 40KgF for the T10 **SD05 SMART+** and 50KgF for the the T12 **SD05 SMART+**
 - Does not rise or fall more than 100mm when released at any point between the fully-open and fully-closed positions
 - Does not rub on or incorrectly make contact with any supporting or surrounding structures

- The horizontal tracks have been installed level, and
- The door panels have been installed level, and
- The vertical tracks have been installed plumb, and
- The junction between the curved horizontal track and the vertical track does not cause the door to 'jump'
- The counterbalance springs on sectional type garage doors must be properly lubricated between all of the coils with heavy automotive bearing grease
- Failure to adequately lubricate the springs may result in one or more of the following:
 - Counterbalance springs may become rusty over time, resulting in additional operating friction between the coils which may cause the **SD05 SMART+** to malfunction
 - Seasonal temperature changes may cause the garage door springs to expand and / or contract. The resultant increase and / or decrease in operating friction may cause the **SD05 SMART+** to malfunction. Properly lubricating the springs will help to minimise changes in operating friction due to the effects of seasonal temperature change
- Repairs to the garage door must be carried out by technically qualified persons. Attempting to repair the garage door without suitable technical qualification may result in severe personal injury, death and / or property damage
- Where possible, install the **SD05 SMART+** at least two meters or more above the ground. Adjust the engage / disengage cord so that it hangs approximately 1.8 meters from the ground
- The header bracket carries ALL of the opening and closing thrust of the **SD05 SMART+** and as such must be securely fastened to a rigid, structural member of the garage wall or ceiling. It is entirely up to the installer to determine the fixing method and the structural suitability of the fixing points
- The engage / disengage instruction tag must remain attached to the engage / disengage cord
- Locate the wall switch;
 - Within site of the garage door, and
 - At a minimum height of 1.5 meters above the ground so that it remains out of the reach of small children, and
 - Away from all moving parts of the garage door
- The entrapment warning label must be secured in a prominent position adjacent to the wall switch
- Do not connect the **SD05 SMART+** to the power outlet until this manual instructs you to do so
- Subsequent to installation and adjustment, the **SD05 SMART+** must stop and reverse direction when it comes into contact with a 40mm high solid object placed on the floor under the garage door
- The correct function of the safety obstruction force system should be checked on a monthly basis
- Never use the **SD05 SMART+** unless the garage door is in full view and free from any object which may impede the movement of the garage door such as cars, children and / or adults
- Never allow children to operate the **SD05 SMART+**
- Never operate the **SD05 SMART+** when any persons are under or near the path of the garage door. Children must be supervised at all times when near the garage door and when the **SD05 SMART+** is in use
- Never attempt to disengage the **SD05 SMART+** to manual operation when there are children/ persons and / or solid objects including motor vehicles under or near the path of the garage door as the garage door may fall sharply upon Manual Release from the **SD05 SMART+**
- Never attempt to open or close the garage door by pulling on the engage / disengage cord
- Never attempt to make any repairs or remove covers from the **SD05 SMART+** without first disconnecting the power supply cord from the main power supply

- Removal of the **SD05 SMART+**'s protective covers must only be performed by a technically qualified person. Attempting to remove the protective covers or repair the **SD05 SMART+** without suitable technical qualification may result in severe personal injury, death and/or property damage
- Install the actuating member for the manual release at a height less than 1,8m
- Install any fixed control at a height of at least 1,5m and within sight of the door but away from moving parts
- For additional safety, we strongly recommend the inclusion of safety beams. Although the **SD05 SMART+** incorporates a pressure sensitive safety obstruction force system, the addition of safety beams will greatly enhance the operating safety of an automatic garage door and provide additional peace of mind. In some countries, it is a mandate of law to fit safety beams. It is the sole responsibility of the owner / installer to fit safety beams in those countries that so require
- Always ensure that the garage door is fully-open and stationary before driving in or out of the garage
- Always ensure the garage door is fully-closed and stationary before moving out of its view
- Adjustments to the safety stop / reverse force settings must only be carried out by a technically qualified person. Attempting to adjust the settings without suitable technical qualification may result in severe personal injury, death and / or property damage
- Keep hands and loose clothing clear of the **SD05 SMART+** and garage door at all times
- In order for the safety obstruction force system to function, it must first encounter an obstruction in the form of an object / person onto which some force **MUST** be exerted. As a result, the object / person / garage door may suffer **DAMAGE AND / OR INJURY**
- The safety obstruction system is designed to work on **STATIONARY** objects only. Serious personal injury, death and / or property damage may occur if the garage door comes into contact with a moving object during an open or close cycle
- Keep remote controls away from children
- Take care when operating the manual release since an open door may fall rapidly due to weak or broken springs or being out of balance
- Permanently fix the labels warning against entrapment in a prominent place or near any fixed controls
- Permanently fix the label concerning the manual release adjacent to its actuating member
- The drive must not be used with a door incorporating a wicket door (unless the drive cannot be operated with the wicket door open)
- After installation, ensure that parts of the door do not extend over public foot paths or roads





1.2. Safe Disposal of Batteries



ATTENTION!

- Do not incinerate
- Do not short the Battery terminals
- Do not charge in a gas tight container
- Do not open
- Recharge after use
- Flush with water at once if contact is made with electrolyte (acid)

2. Product Specifications

FAST TRACK HYPERLINKS

- 2.1. [Physical Dimensions](#)
- 2.2. [Technical Specifications](#) 
- 2.3. [Maximum Door Size](#) 
- 2.4. [Fuse Protection](#) 



Please note that images in this installation manual are not to scale.

2.1. Physical Dimensions

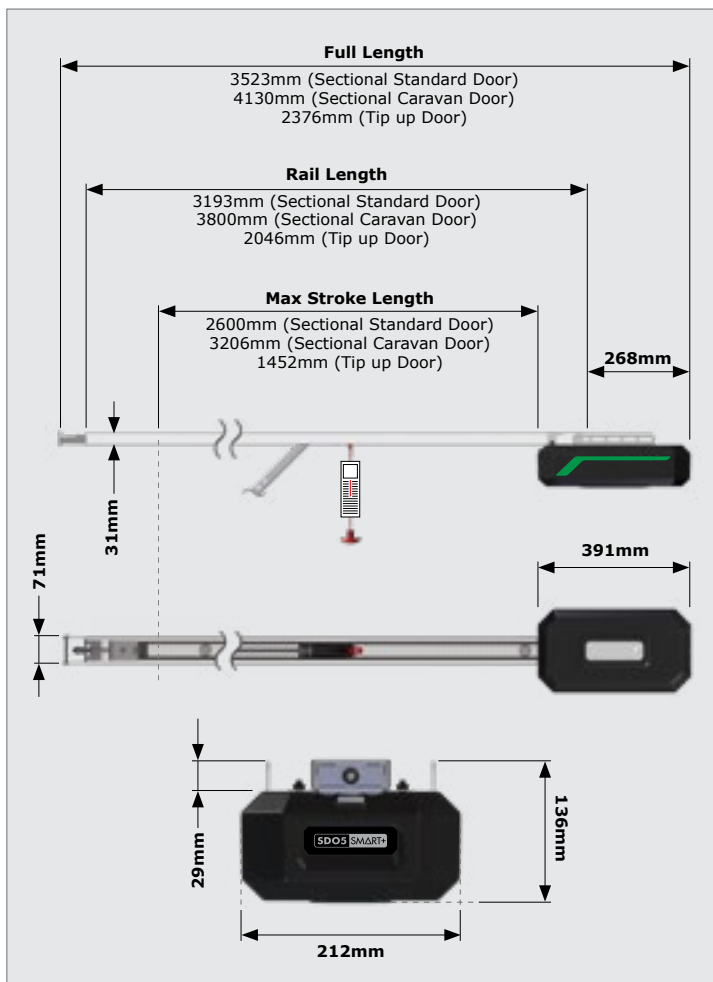

FIGURE 1. OVERALL DIMENSIONS FOR THE SD05 SMART+

2.2. Technical Specifications

	SDO5 SMART+ T10	SDO5 SMART+ T12
Input voltage	230V AC @ 50/60Hz ¹	
Motor voltage	24V DC	
Motor power - rated	80W DC	100W DC
Motor supply	Mains driven 110 VA Thermally fused Toroidal Transformer	Mains driven 150 VA Thermally fused Toroidal Transformer
Max door width	6500mm	
Max door area	12 square metres	15 square metres
Max holding capacity	1000N	1200N
Maximum push/pull force	40kgf	50kgf
Battery Backup	Optional 2.9Ah Battery Backup ² 870mA Charging Rate with built-in Battery Saving and testing functionality	
Operations in standby mode³	Up to 70 depending on the door size/weight/height/ duration of power failure/condition of batteries ³	
Operator travel speed⁴	9m/min	
Wireless Communication	BLE and Wi-Fi (2.4Ghz)	
Door travel adjustment	Physical Endstops (Automatic limit set)	
Safety obstruction force system	Built-in Hall Effect and Current-sensing. Adjustable in MyCentys Pro	
Light	Integrated LED Courtesy Light	
Autoclose⁵	Adjustable in MyCentys Pro ⁵	
Infrared safety beams	Compatible with Wired or Wireless. (Optional but recommended) Configured in MyCentys Pro	
Radio receiver	Code-hopping 433MHz	
Receiver code storage capacity	30x 4-button NOVA transmitters	
Degree of protection	IPX0 (For interior use only)	

1. Can operate off a solar supply, please consult Centurion Systems (Pty) Ltd for assistance.

2. Add-on Battery Backup kit sold separately. Contact your local stockist for assistance.

3. Only applicable if battery backup is installed.

4. Speed varies with load.

5. Requires Infrared Safety Beams to be fitted.

TABLE 1

2.3. Maximum Door Size

	Sectional Standard Door	Sectional Caravan Door	Tip up Door
Max door width	6500mm		
Max door height	2600mm	3206mm	2135mm

TABLE 2

2.4. Fuse Protection

The following protection fuses are provided on the system:

Item	Type	Rating
Main controller		
Motor circuit	ATO	15A

TABLE 3

3. Product Identification

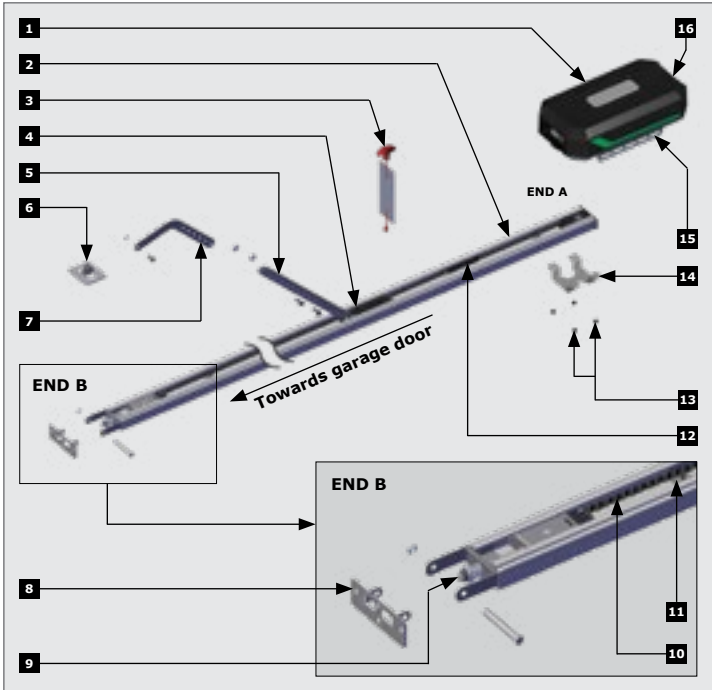

FIGURE 2. SDO5 SMART+ PRODUCT IDENTIFICATION

- | | |
|--|--|
| 1. SDO5 SMART+ Control Head Unit | 9. Tensioning Nut and Spring |
| 2. Rail | 10. Drive Belt |
| 3. Release Handle Warning Label | 11. Endstop |
| 4. Carriage | 12. Belt Bullet |
| 5. Straight Towing Arm | 13. M6 Nuts |
| 6. Towing Bracket | 14. Rail-holder Bracket |
| 7. Bent Towing Arm | 15. Metal Chassis Hanging Rail |
| 8. Header Bracket | 16. Screw to remove the Control Head Cover |

3.1. Fasteners List and Spares

Description	QTY
ST5.5 x 50 Self-tapping Coach Screws	4
ST8 x 60 Self-tapping Screws	3
ST6.3 x 25 Self-tapping Screws - Hex Flange Head	3
M6 x 8 Black Cross Pan Head Screws	2
M8 x 20 Hexagon Head Bolts	6
M6 Nuts	4
M8 Wizzlock Nuts	8
Ø8 x 71 Clevice Pin	1
Ø8 x 18 Black Clevice Pin	1
Ø2 Hairpin Clips	2
12 x 60mm Fischer Plugs	3
M8 x 25(Pitch 1.25) Black Gutter Bolts	2

TABLE 4

4. Required Tools and Equipment



FIGURE 3. REQUIRED TOOLS AND EQUIPMENT

5. Preparation of Site

5.1. General Considerations for the Installation

Always recommend the fitment of additional safety equipment such as safety edges and safety beams, for additional protection against entrapment or other mechanical risks.

Ensure that no pipes or electrical cables are in the way of the intended installation.

Install the garage operator only if:

- It will not pose a hazard to the public
- The installation will meet all municipal and/or local authority requirements once completed
- The door mass and application is within the operator specifications
- There is a properly-earthed general purpose 220-240V AC power outlet that has been installed by a qualified electrical contractor
- All locks, ropes and / or securing mechanisms have been removed
- The ceiling structure is adequate enough to support the weight of the **SD05 SMART+**
- The garage door is in good working order, meaning:
 - it opens freely;
 - it is well-balanced;



An improperly-balanced or malfunctioning garage door could cause serious personal injury, death and / or property damage. Have a qualified person check and, if required, make repairs to the garage door before installing the **SD05 SMART+**.

- it does not move on its own if left in any position for more than 100mm;
- it can be installed to have sufficient clearance between moving parts when opening or closing to reduce the risk of personal injury and / or entrapment



Any repairs to the garage door that need to be done due to any of the above requirements not being in place, must be carried out by technically qualified persons.



Attempting to repair the garage door without suitable technical qualifications, may result in severe personal injury, death, and / or property damage.

6. Operator Installation

FAST TRACK HYPERLINKS

6.1. Assembly Instructions [🔗](#)

6.1.1. Identifying the Garage Door Type [🔗](#)

6.1.2. General Assembly [🔗](#)

6.1.3. Tensioning the Belt [🔗](#)

6.2. Installation Instructions [🔗](#)

6.2.1. Sectional Standard Doors and Sectional Caravan Doors [🔗](#)

6.2.1.1. Mounting the Header Bracket [🔗](#)

6.2.1.2. Mounting the **SD05 SMART+** to the Header Bracket [🔗](#)

6.2.1.3. Mounting the **SD05 SMART+** Drive Rail to the Ceiling [🔗](#)

6.2.1.4. Mounting the Towing Bracket to the Garage Door [🔗](#)

6.2.1.5. Fitting the Bent Towing Arm to the Towing Bracket and Straight Towing Arm [🔗](#)

6.2.2. Tip Up Doors [🔗](#)

6.2.2.1. Mounting the Header Bracket [🔗](#)

6.2.2.2. Mounting the **SD05 SMART+** to the Header Bracket [🔗](#)

6.2.2.3. Mounting the **SD05 SMART+** Drive Rail to the Ceiling [🔗](#)

6.2.2.4. Mounting the Towing Bracket to the Garage Door [🔗](#)

6.2.2.5. Fitting the Bent Towing Arm to the Towing Bracket and Straight Towing Arm [🔗](#)

6.3. Retro-fit Installations [🔗](#)

6.4. Engaging and Disengaging the Motor [🔗](#)

6.5. Emergency Lock Functionality [🔗](#)

6.6. Positioning the Opening and Closing Endstops [🔗](#)

6.6.1. Positioning the Closing Endstop [🔗](#)

6.6.2. Positioning the Opening Endstop [🔗](#)

6.7. The Wireless Wall Switch [🔗](#)

6.8. Safety Beams [🔗](#)

6.8.1. Four-wire Safety Beams [🔗](#)

6.9. Connecting to a Power Supply [🔗](#)

6.10. Battery Backup [🔗](#)

6.10.1. Removing the **SD05 SMART+** Cover [🔗](#)

6.10.2. Installation of the Battery Kit [🔗](#)

6.1. Assembly Instructions

6.1.1. Identifying the Garage Door Type

Identify the garage door type and then select the preferred installation method and assembly type that is best-suited to the application.

Sectional Standard Doors

- Use a 3193mm one-piece drive rail
- The standard 3193mm drive rail will lift a door up to 2600mm high
- The **SDO5 SMART+** is supported with a metal chassis in the drive head which is hung from the ceiling using appropriate hanging material
- The drive rail must be perpendicular to the door as shown in Figure 4
- The header bracket may be mounted on the front wall of the garage or on the ceiling adjacent to the front wall

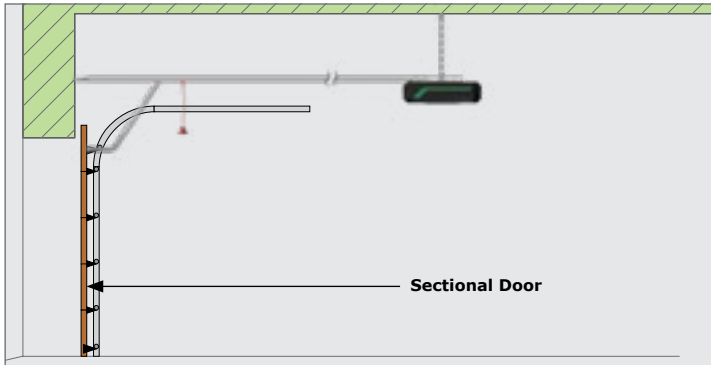

FIGURE 4. SECTIONAL STANDARD DOORS

Sectional Caravan Doors

- Use a 3800mm one-piece drive rail
- The 3800mm drive rail will lift a door up to 3206mm high
- The **SDO5 SMART+** is supported with a metal chassis in the drive head which is hung from the ceiling using appropriate hanging material
- The drive rail must be perpendicular to the door as shown in Figure 5
- The header bracket may be mounted on the front wall of the garage or on the ceiling adjacent to the front wall

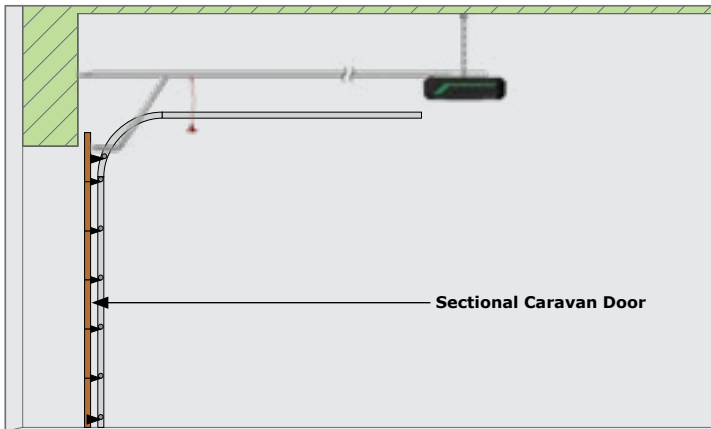

FIGURE 5. SECTIONAL CARAVAN DOORS

Tip up Doors

- Use a 2046mm one-piece drive rail
- The **SDO5 SMART+** is supported with a metal chassis in the drive head which is hung from the ceiling using appropriate hanging material
- The drive rail must be angled, so that the pivot points at each end of the connecting arm should be as close to horizontal as possible when the door is in the fully-open position
- The header bracket may be mounted on the front wall of the garage or on the ceiling adjacent to the front wall

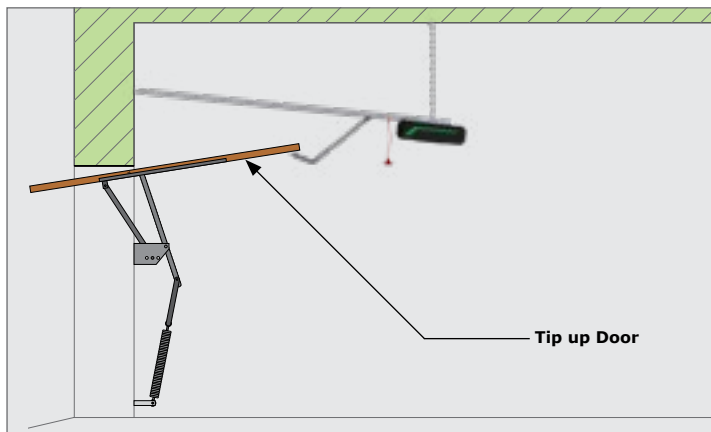

FIGURE 6. TIP UP DOORS

6.1.2. General Assembly

Open the packing carton and expose the **SDO5 SMART+** components, and orientate the drive rail so that the terminal bracket faces towards the garage door.

1. Orientate the Drive Rail as shown in Figure 7, and fit 'End A' over the motor coupling found on top of the **SDO5 SMART+** Head Unit.

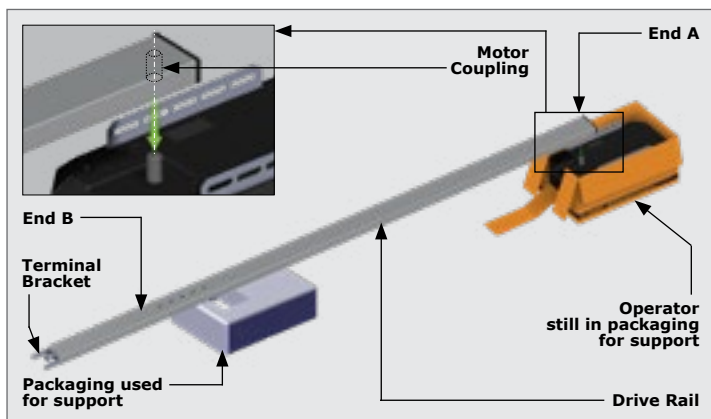

FIGURE 7



Keep the **SDO5 SMART+** Head Unit in its packaging for support, and use the other half of the packaging to support the far end of the Drive Rail ('End B').

- Swing the track from side to side should the motor coupling struggle to engage with the shaft.



It is highly recommended to complete Step 4 with the Head Unit still inside its packaging. This is to protect it from possible damage and scratching.

- Place the Rail-holder Bracket into position over the four threaded studs found on top of the **SD05 SMART+** Head Unit and Secure the Rail-holder Bracket into position using the 4x supplied Black M6 nuts and a 10mm Socket (Figure 8).

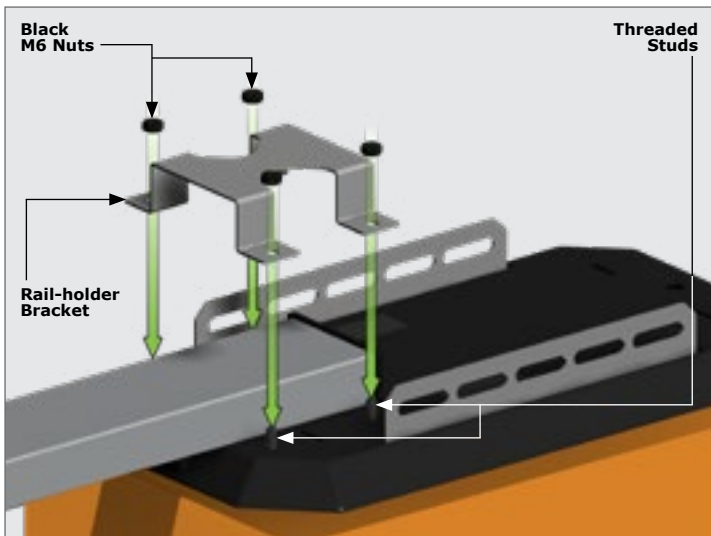

FIGURE 8

6.1.3. Tensioning the belt

The belt comes pre-tensioned from the factory; however, ensure that the spaces between the spring windings are 0.5-1mm. Use a 13mm socket and wrench to tighten the drive should there, for whatever reason, be a deviation from these values.

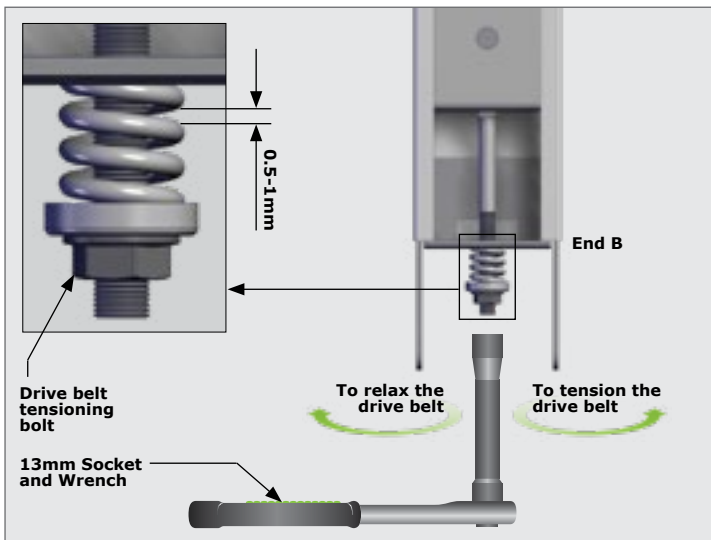

FIGURE 9

6.2. Installation Instructions

6.2.1. Sectional Standard doors and Sectional Caravan doors

(For Tip up Doors skip to Section 6.2.2)



Before commencing the installation, ensure that you have carefully read and understood all safety recommendations. In particular, ensure that the installation of the garage door complies with the requirements specified. Make any necessary adjustments to the garage door **BEFORE** commencing the installation!

Important considerations to note before commencing installation

- Sectional Standard Doors;
The opening heights are 2600mm for standard Sectional doors
- Sectional Caravan Doors;
The opening heights are 3206mm for Caravan-height Sectional doors
- The structure is level, square and plumb
- For sectional doors, the door panel overlaps the opening by no more than 30mm at the top, and sides.



Door traveling path

The travel path of a garage door is determined by the path the top section of the garage door takes as the door is being opened or closed.

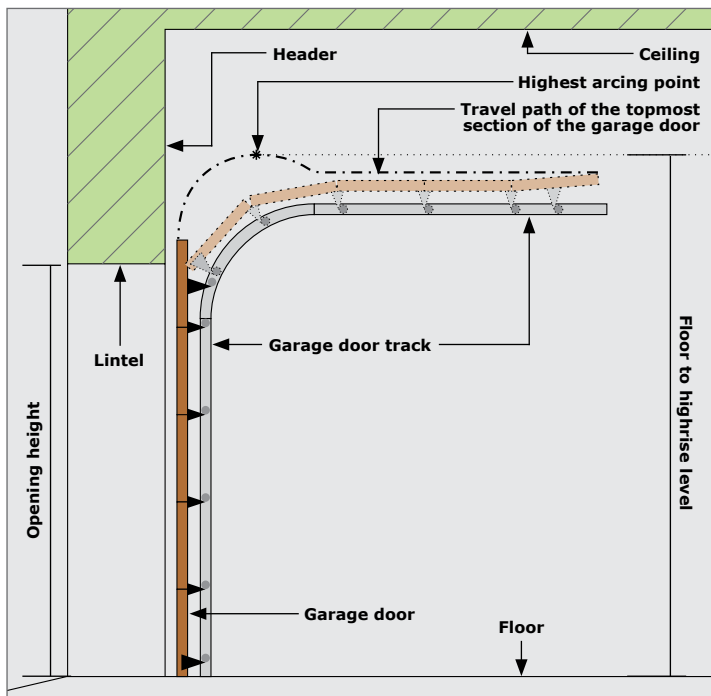

FIGURE 10

6.2.1.1. Mounting the header bracket



The header bracket carries **ALL** of the opening and closing thrust of the SD05 SMART+ and, as such, must be securely fastened to a rigid, structural member of the garage. It is entirely up to the installer to determine the fixing method and the structural suitability of the fixing points.



When marking important lines needed for mounting the header bracket, ensure that a spirit level is used, as it is imperative that these lines are as level and straight as possible.

Determine the highest arcing point of the garage door and mark this as a horizontal line on the header above the top edge of the garage door.

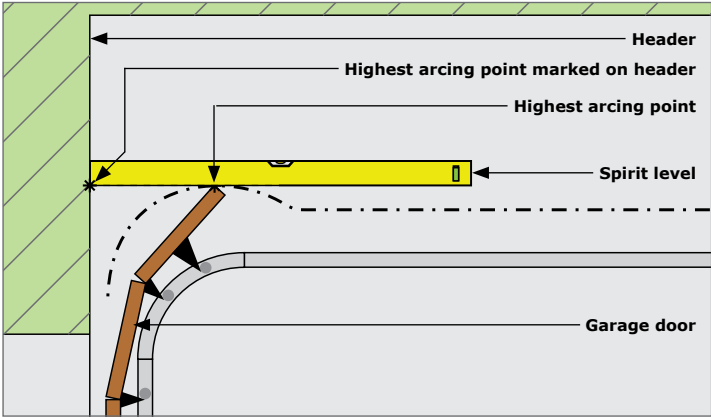

FIGURE 11

Close the garage door, and determine the garage door center-line and mark a vertical line on the header above the door.

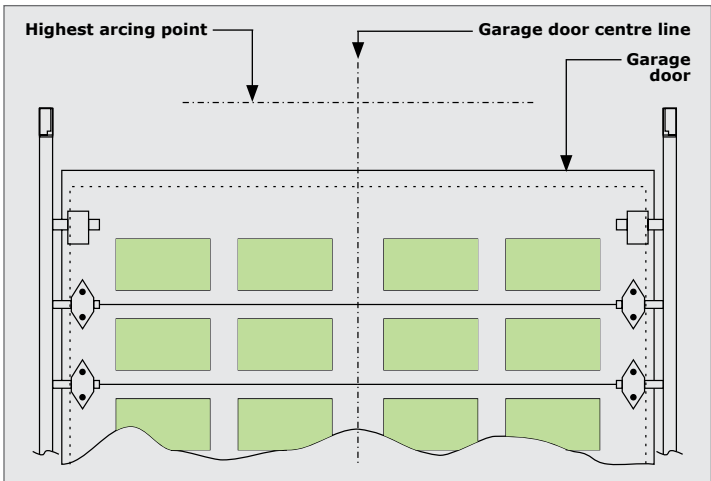

FIGURE 12

Place the header bracket on the wall as shown in Figure 13. Ensure that the **bottom edge** of the bracket is level, and **no more than 50mm above** the highest arcing point of the garage door. Mark the location of the four screw holes (Hole A, B, C and D[optional]).

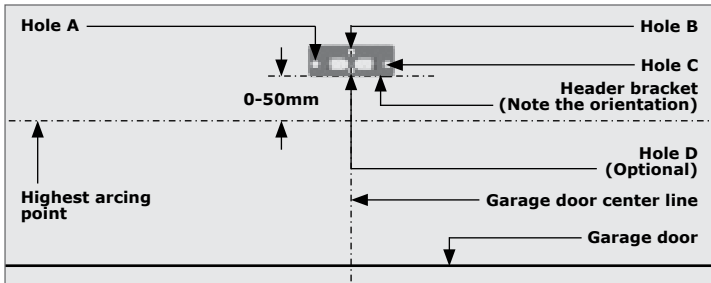

FIGURE 13



Note the orientation of the header bracket.



Mounting the drive rail more than 50mm above the highest arcing point of the garage door may cause the drive rail to flex excessively.

Drill four 11mm diameter holes in position of 'Hole A', 'Hole B', 'Hole C' and 'Hole D'(optional), at least 50mm deep.

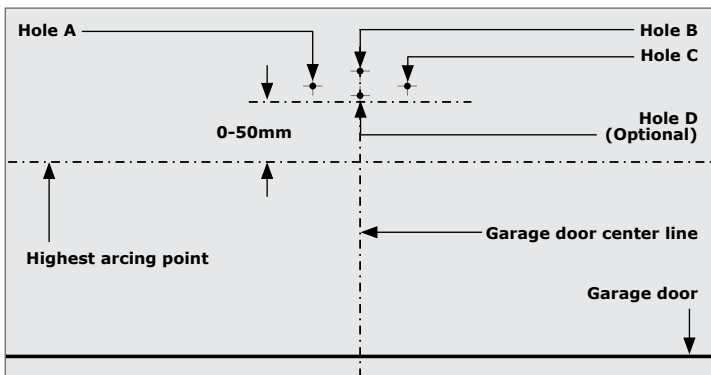

FIGURE 14

Place a fischer plug in each hole, followed by the header bracket. Secure it in position with at least three coach screws (supplied) (13mm hexagonal head).

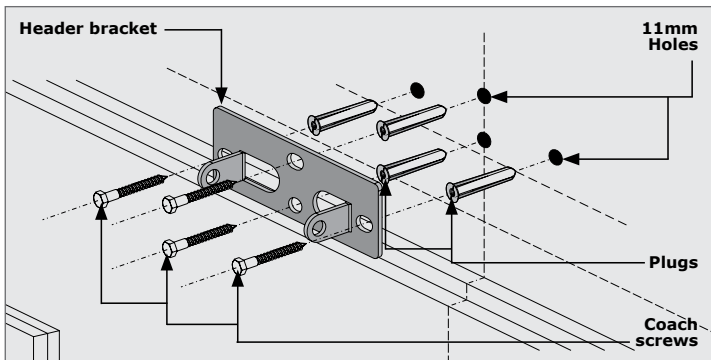

FIGURE 15



If, after securing the header bracket, it is slightly out (not level), use a hammer to knock the tabs gently up or down with a small spirit level placed on top of them. This will ensure a perfectly level installation (Figure 16).

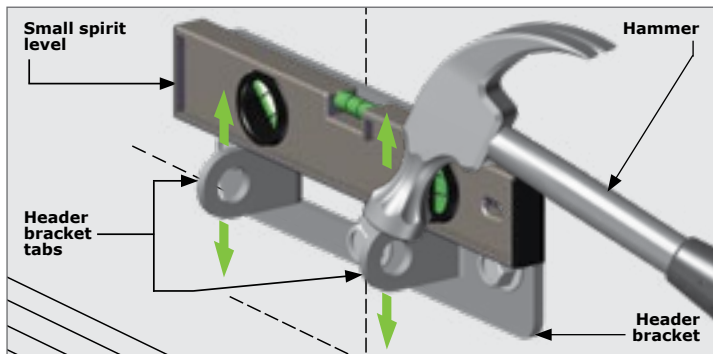

FIGURE 16

6.2.1.2. Mounting the **SD05 SMART+** to the header bracket



If the Optional Battery Backup Kit has been purchased, it is important at this point of the installation to ensure that it is now installed and connected. Refer to **Section 6.10** - "Battery Backup" before continuing with the installation.

Position the **SD05 SMART+** in place, with the open end of the drive rail facing the floor, and the tensioning bracket towards the garage door. You will need a second person to assist you with this.

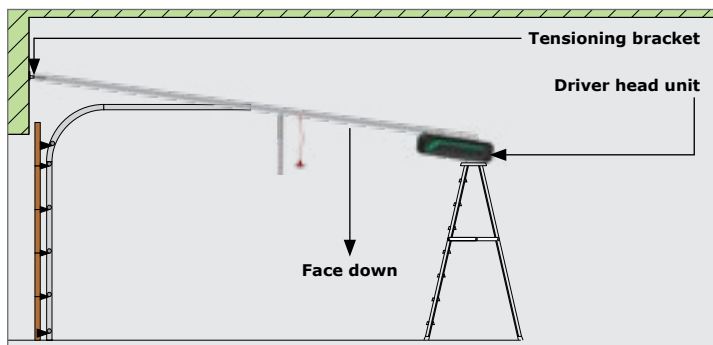

FIGURE 17



If you are on your own, use a ladder to support the control unit end of the **SD05 SMART+** while you are positioning it for the next step (Figure 17).

Align the holes on the side of the tensioning bracket with the holes of the header bracket.

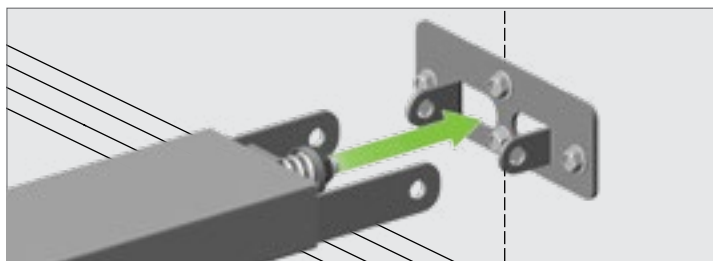

FIGURE 18

Locate the long clevis pin through the holes and secure it into position with a supplied E-Clip on the other end of the clevis pin.



Split Pins have also been supplied should they be preferred over the use of the circle pin clips.

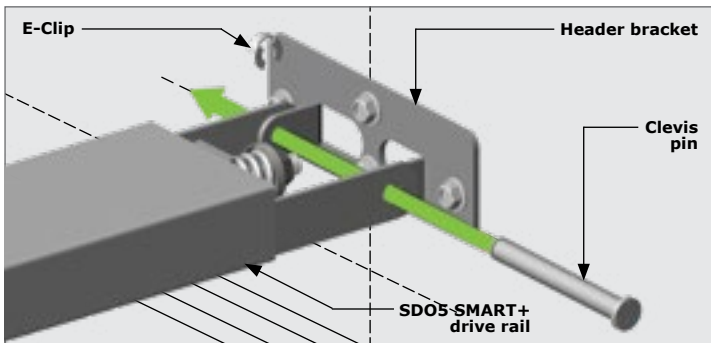

FIGURE 19

6.2.1.3. Mounting the **SDO5 SMART+** drive rail to the ceiling

Open the garage door, and rest the **SDO5 SMART+** on top of the open door.



If your ladder is high enough, we recommend resting it on top of the ladder.

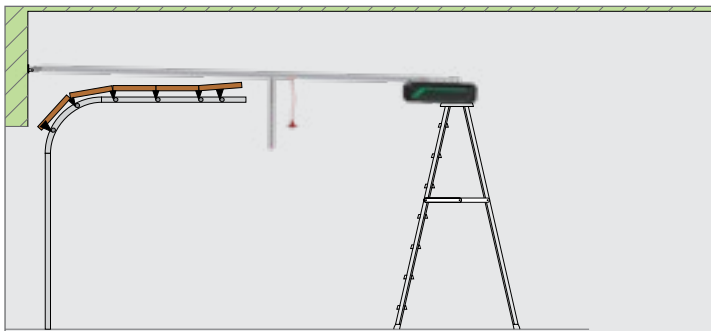

FIGURE 20

Find the centre line of the garage door, and mark it on the ceiling above the location of the **SDO5 SMART+** Head Unit.



You can use the **SDO5 SMART+** Drive Rail as a gauge to assist you if needed.

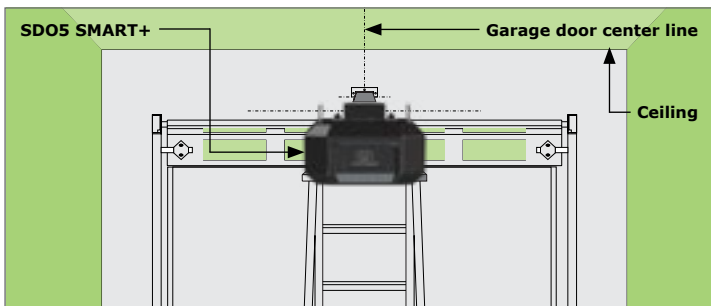

FIGURE 21

Use a long spirit level along the length of the **SD05 SMART+** drive rail, and level out the **SD05+ SMART**, so that it is running parallel to the ceiling.

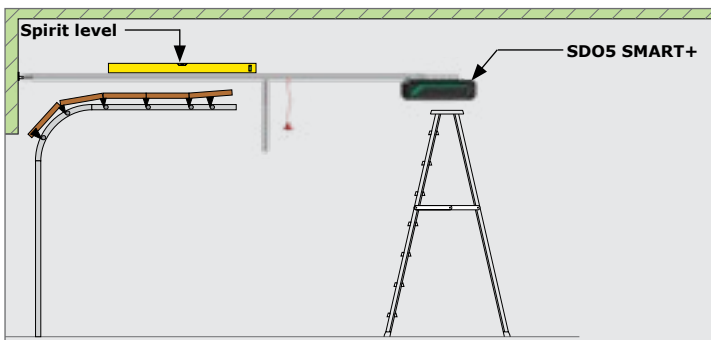

FIGURE 22

Place a second spirit level perpendicular to the ceiling, aligning it with the center of one of the holes on the Metal Support Chassis at the top of the **SD05 SMART+** Head Unit. Make a mark on the ceiling, and repeat this for the other Metal Support Chassis on the other side of the Head Unit.



Ensure the Metal Support Chassis is positioned directly beneath a strong structural member in the ceiling. Adjust the spirit level so it aligns with a hole in the Metal Support Chassis that sits directly under this structural member.

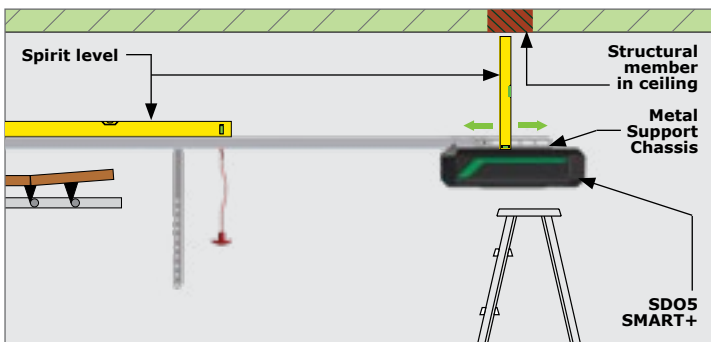

FIGURE 23

Draw a line on the ceiling joining these two marks, perpendicular to the garage door center line made earlier.

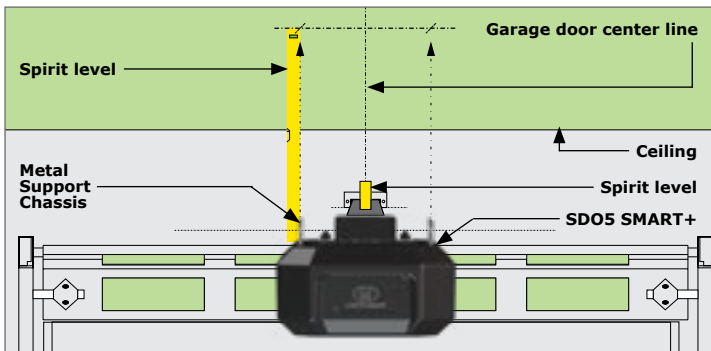

FIGURE 24

Measure and cut a 300mm length of punched angle iron with a pair of tin snips.



Snip off the four corners of the punched angle iron to add a degree of safety and neatness to the installation.

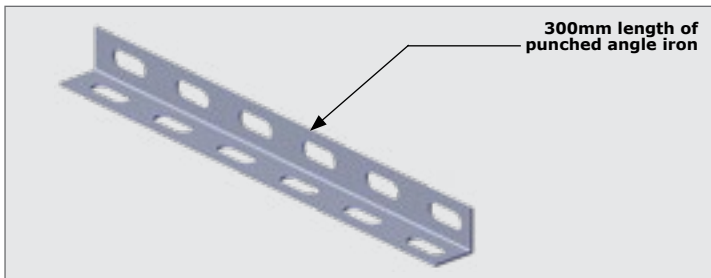

FIGURE 25

Align the punched angle iron centered onto the garage door center line, and the perpendicular line running along the center of the horizontal face holes. The horizontal face must face the back of the garage. Secure the punched angle iron to the ceiling with suitable screws (depending on the structural member of the ceiling).



Ensure that the punched angle iron is mounted to a strong structural member in the ceiling.

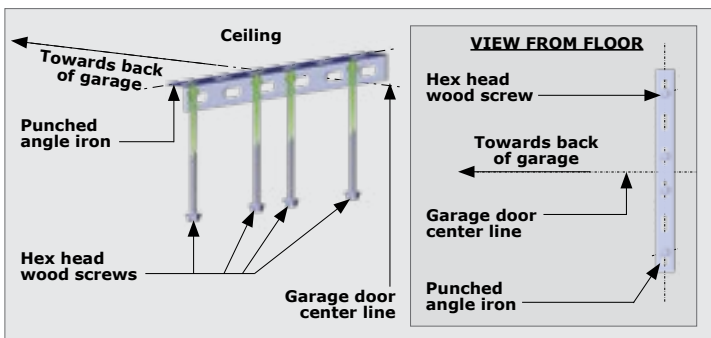

FIGURE 26

Level the **SDO5 SMART+** again, and measure the length needed from the ceiling to the hole directly underneath on the Metal Support Chassis marked as 'Value Xmm' in Figure 27.

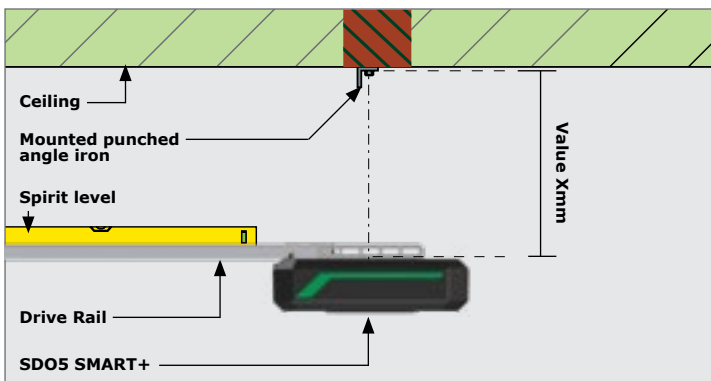

FIGURE 27

Using an angle grinder or hack saw, cut two lengths of punched angle iron to the measurement taken for 'Value Xmm'.



Snip off the corners of the punched angle iron to add a degree of safety and neatness to the installation.

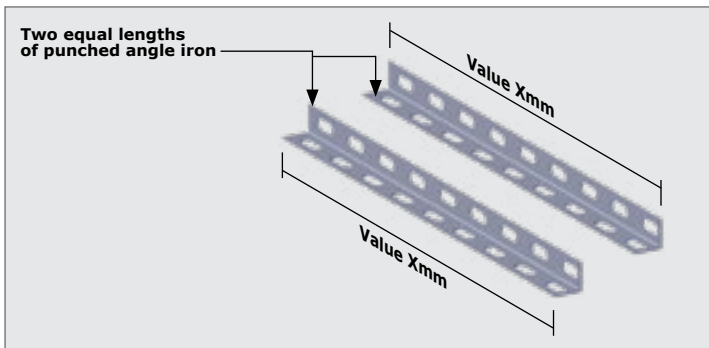

FIGURE 28

Locate the two lengths of punched angle iron into position as shown in Figure 29, and secure them in position with the two M8 Wizzlock Nuts, and two M8X20 Hexhead Bolts.

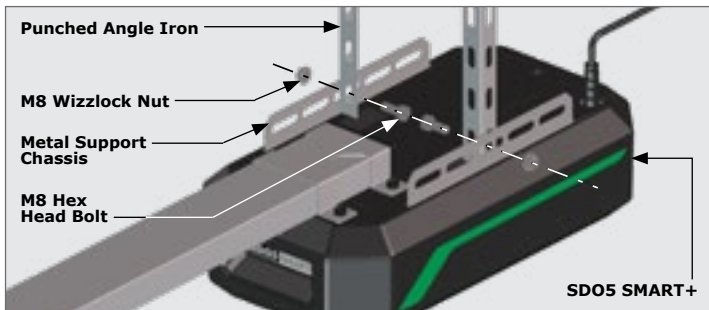

FIGURE 29

Use a spirit level to ensure that the **SD05 SMART+** is still level and parallel to the ceiling. Align the holes of the punched angle iron mounted to the ceiling, with the holes on the punched angle iron mounted to the Metal Support Chassis. Secure it in position using two supplied M8 Wizzlock Nuts and M8X20 bolts using a 13mm socket.

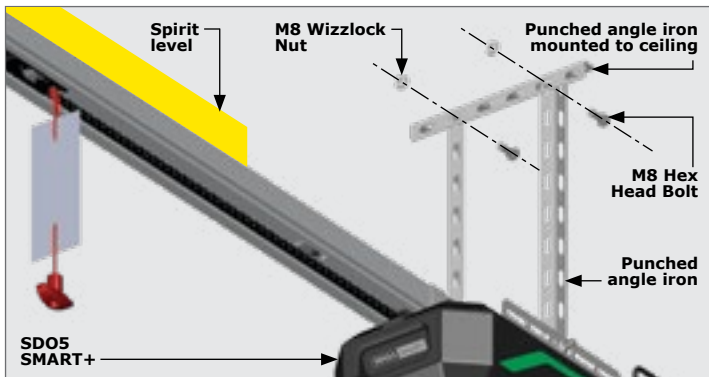

FIGURE 30



Using a spirit level, ensure that the **SD05 SMART+** is level on both the X-Axis and Z-Axis of the horizontal plain. If it is not, it may cause the motor to stress, or the drive rail to twist.

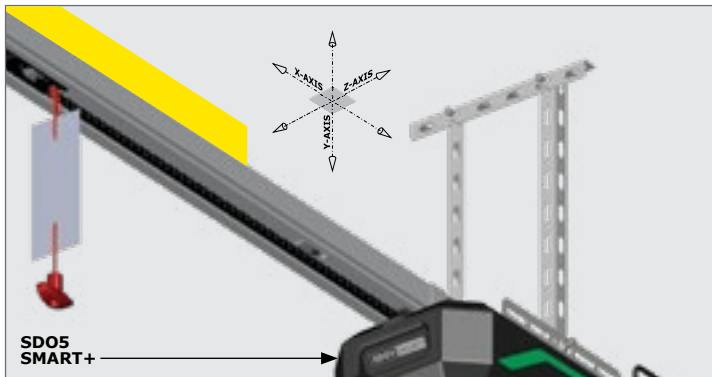

FIGURE 31

Correct and incorrect configurations for mounting the **SD05 SMART+** to the ceiling.

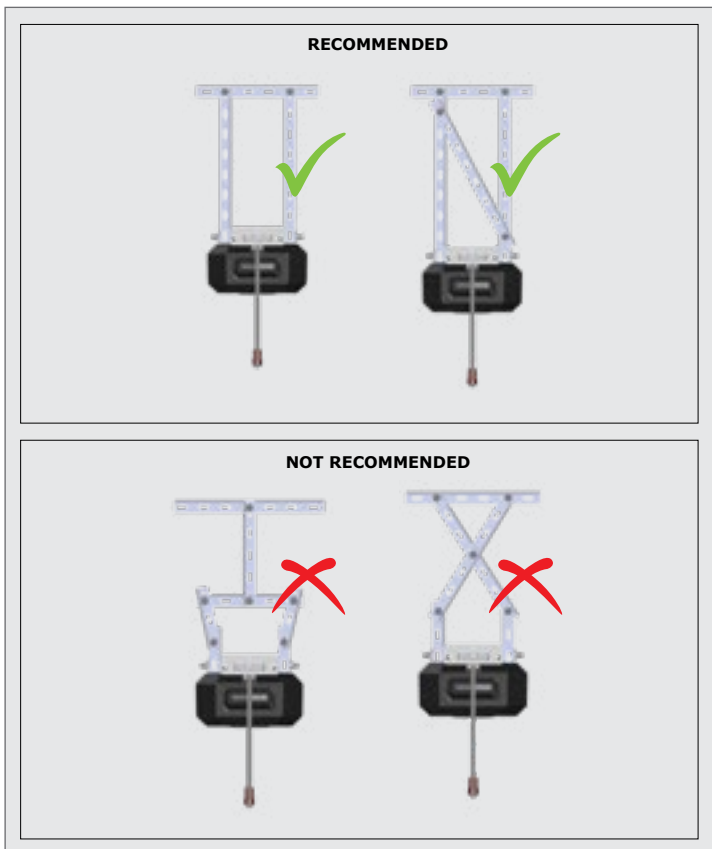

FIGURE 32. CORRECT AND INCORRECT MOUNTING CONFIGURATIONS

6.2.1.4. Mounting the Towing Bracket to the Garage Door

Close the garage door, and find its center line. Make a level mark perpendicular to the garage door center line, and in line with the top edge of the top roller of the garage door.

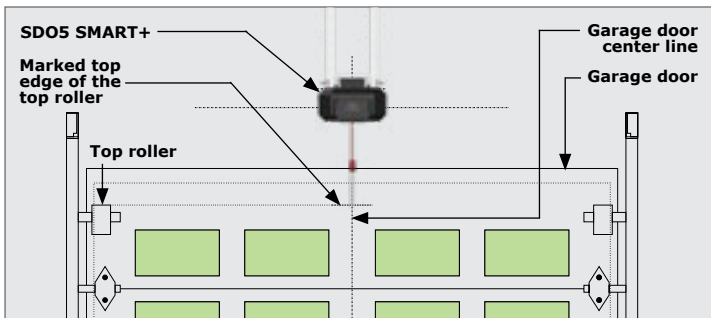

FIGURE 33

Center the towing bracket on the garage door center line and so that the center of the two holes on the protruding tabs are in line with the top edge of the top roller.



Place a small spirit level on the top edge of the towing bracket, to ensure that it is level when drilling holes.

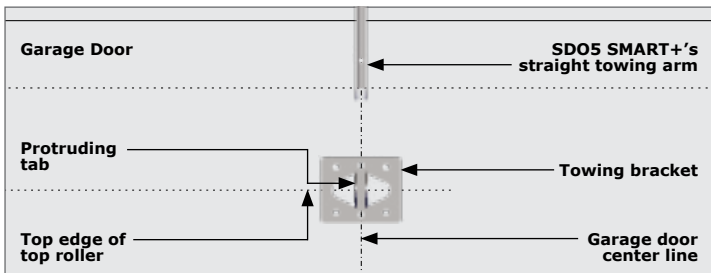

FIGURE 34

Secure the towing bracket into position using the three hexagonal head self-tapping screws supplied.

- If the garage door is heavier than average, more screws can be used to fix the bracket to the garage door.
- Ensure that the length of the screws do not exceed the depth of the garage door.
- The above method is for the purpose of wooden garage doors. Should you have a garage door that is not constructed from wood, such as a steel garage door, we recommend the use of high-quality Tek screws to secure the towing bracket to the garage door.

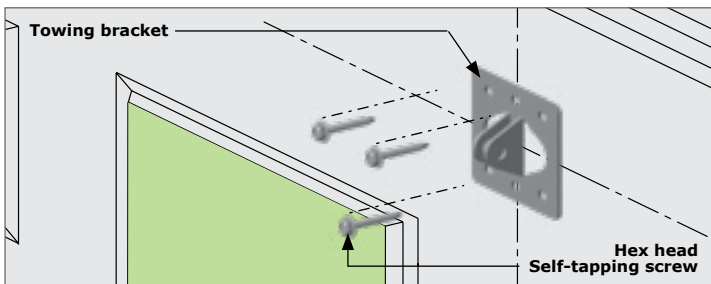

FIGURE 35

6.2.1.5. Fitting the bent towing arm to the towing bracket and straight towing arm.

Slot the bent towing arm between the two protruding tabs of the towing bracket, and align the holes. Note the orientation of the bent towing arm.

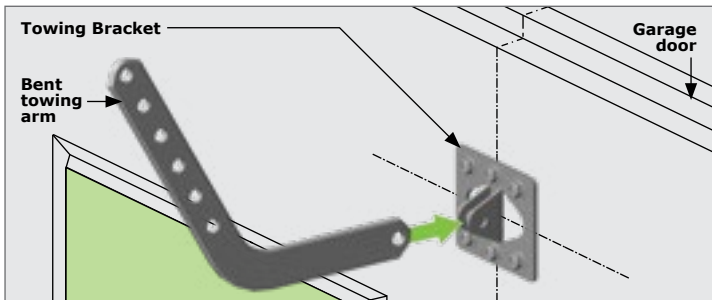

FIGURE 36

Locate the short clevis pin through the holes and secure it into position with a supplied E-Clip on the other end of the clevis pin.



Split Pins have also been supplied should they be preferred over the use of the circle pin clips.

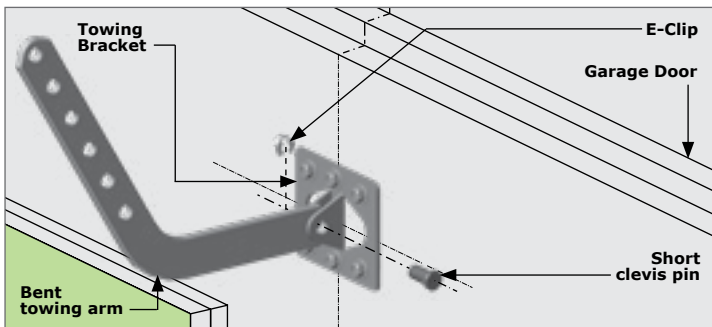

FIGURE 37

Slot the bent towing arm into the straight towing arm, and align the holes. If they do not align, move the carriage up or down the drive rail in order to align the holes of the bent and straight towing arms.



Ensure that the two towing arms overlap by at least two holes. This will ensure a strong join, and prevent the arm from swiveling whilst the motor is in operation.

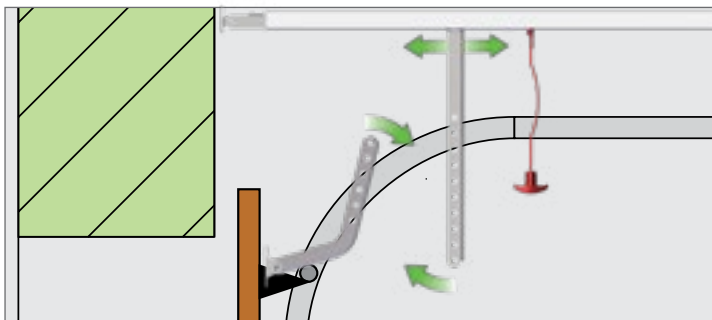

FIGURE 38

The two towing arms must be joined in such a way that they are just short of parallel to the garage door and the ceiling. Angle 'Z' should be $\pm 80^\circ$ when the garage door is in the closed position, as shown in Figure 39. This will put less strain on the motor on start-up and, furthermore, aid in preventing the garage door from being forced open by hand.

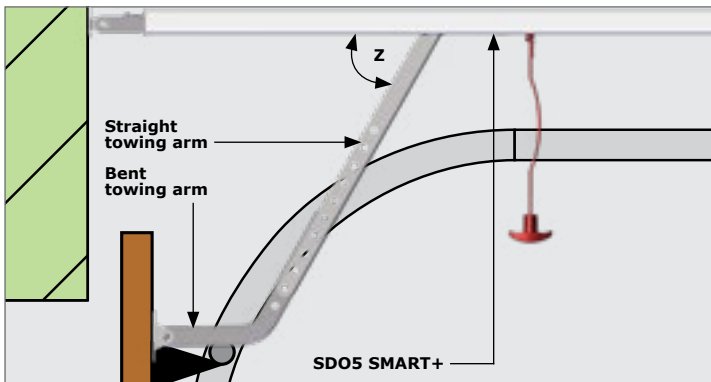

FIGURE 39

Once aligned, secure the towing arms into position using the two supplied Wizzlock Nuts and M8x20 Hex Head Bolts: one set through the bottom hole of the straight towing arm, and the other through the top hole of the bent towing arm.

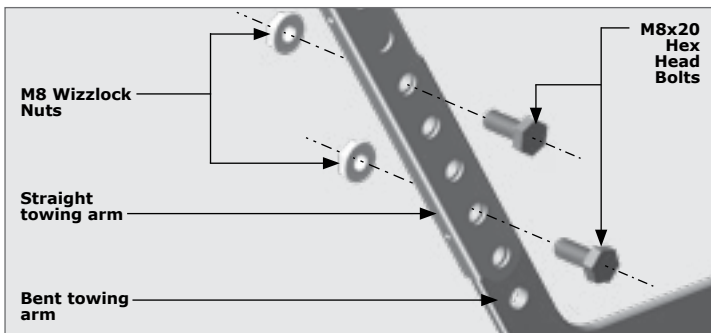

FIGURE 40

Please do not forget to affix the safety sticker and tag.

The **SD05 SMART+** is now installed and ready for programming.

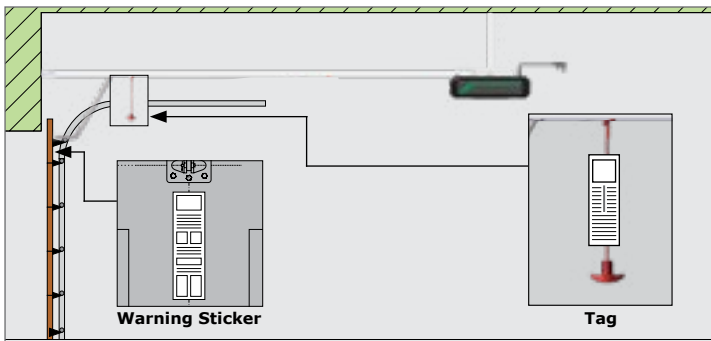

FIGURE 41

6.2.2. Tip doors



Before commencing the installation, ensure that you have carefully read and understood all safety recommendations. In particular, ensure that the installation of the garage door complies with the requirements specified. Make any necessary adjustments to the garage door **BEFORE** commencing the installation!

**Important considerations to note before commencing installation**

- The opening heights are 2135mm for standard doors
- The structure is level, square and plumb

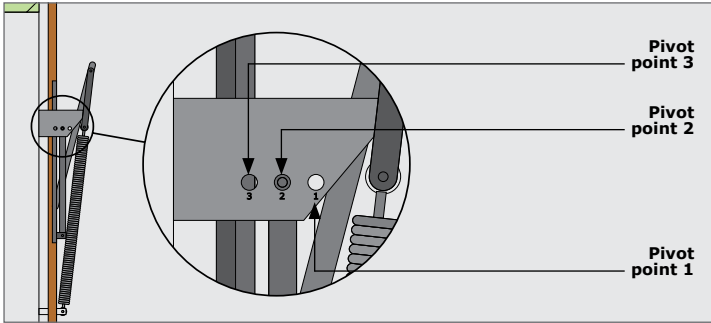

FIGURE 42

Pivot position No. 1 or 2 (140mm or more head room) is recommended for automation. If insufficient headroom is available, contact an approved garage door installer to assist with possible modifications

Door traveling path

The travel path of a garage door is determined by the path that the top section of the garage door takes as the door is being opened or closed.

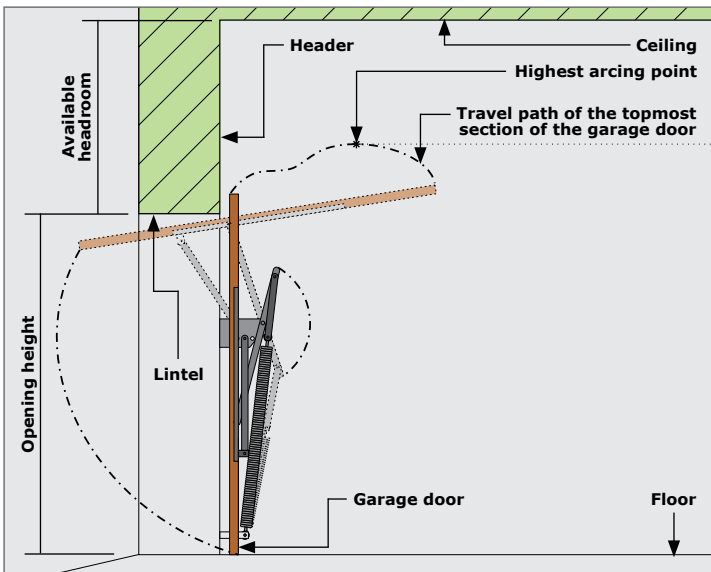

FIGURE 43

6.2.2.1. Mounting the header bracket



The header bracket carries **ALL** of the opening and closing thrust of the SDO5 SMART+ and as such must be securely fastened to a rigid, structural member of the garage. It is entirely up to the installer to determine the fixing method and the structural suitability of the fixing points.



When marking important lines needed for mounting the header bracket, ensure that a spirit level is used, as it is imperative that these lines are as level and straight as possible.

Determine the highest arcing point of the garage door and mark this as a horizontal line on the header above the top edge of the garage door.

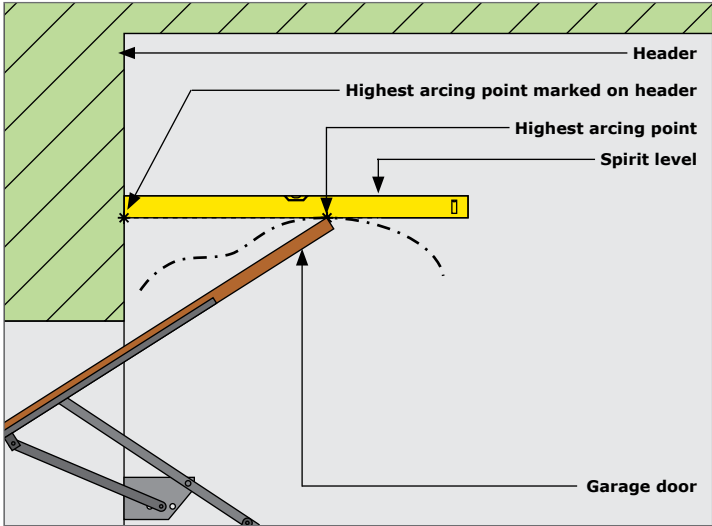

FIGURE 44

Close the garage door, and determine the garage door center line and mark a vertical line on the header above the door.

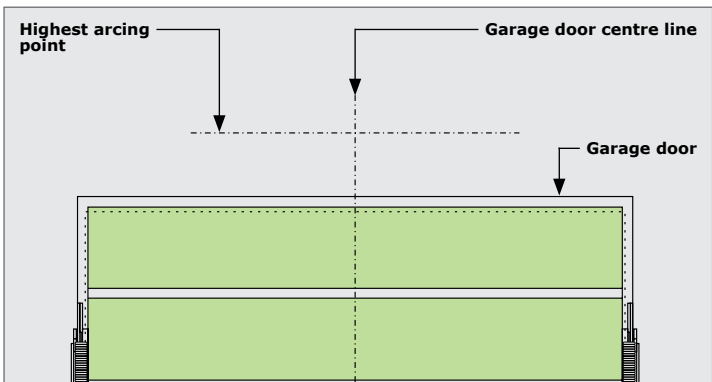

FIGURE 45

Place the header bracket on the wall as shown in Figure 46. Ensure that the **bottom edge** of the bracket is level, and between 20mm - 50mm, but no more than 50mm above the highest arcing point of the garage door. Mark the location of the three screw holes (Hole A, B, C and D[optional]).

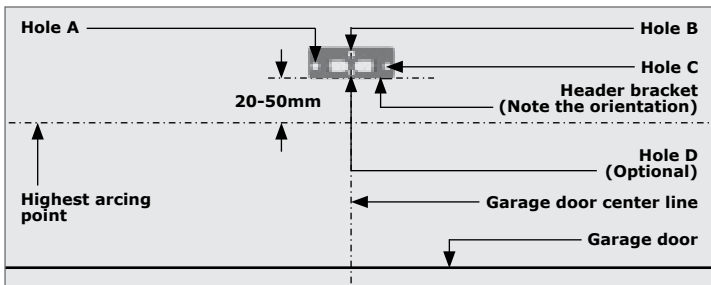

FIGURE 46



Note the orientation of the header bracket.



Mounting the drive rail more than 50mm above the highest arcing point of the garage door may cause the drive rail to flex excessively.

Drill four 11mm diameter holes in position of 'Hole A', 'Hole B', 'Hole C' and 'Hole D'(optional), at least 50mm deep.

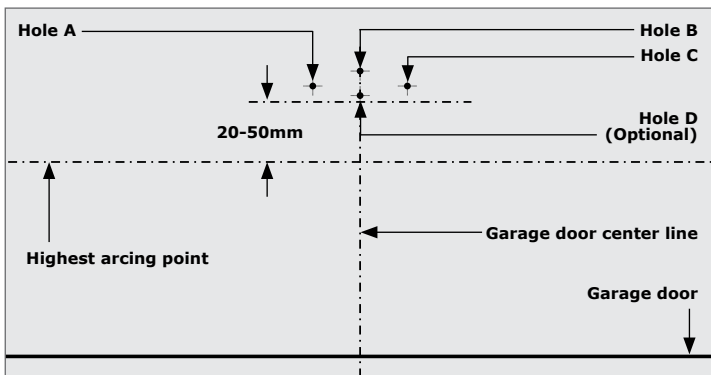

FIGURE 47

Place a fischer plug in each hole, followed by the header bracket. Secure it in position with at least three coach screws (supplied) (13mm hexagonal head).

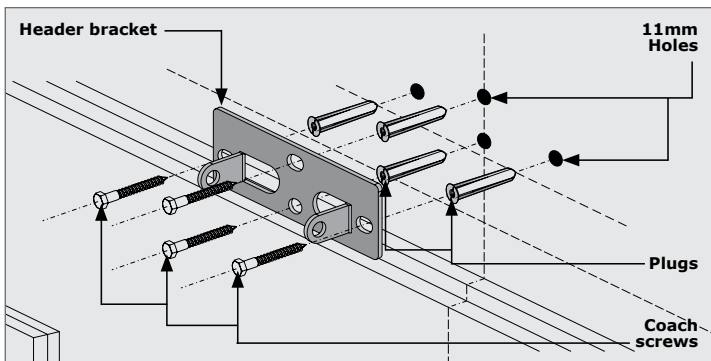

FIGURE 48



If, after securing the header bracket, it is slightly out (not level), use a hammer to knock the tabs gently up or down with a small spirit level placed on top of them. This will ensure a perfectly level installation (Figure 49).

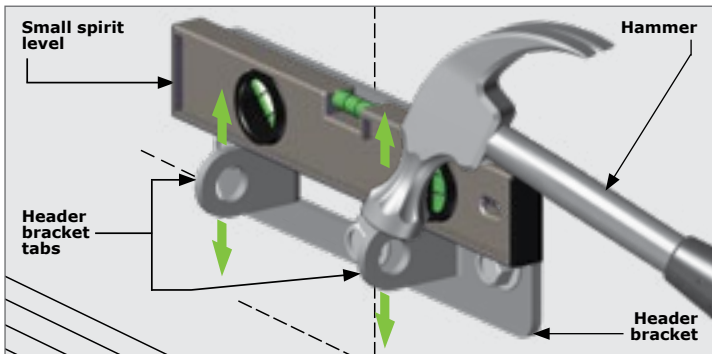

FIGURE 49

6.2.2.2. Mounting the **SD05 SMART+** to the header bracket



If the Optional Battery Backup Kit has been purchased, it is important at this point of the installation to ensure that it is now installed and connected. Refer to **Section 6.10.** - "Battery Backup" before continuing with the installation.

Position the **SD05 SMART+** in place, with the open end of the drive rail facing the floor, and the tensioning bracket towards the garage door. You will need a second person to assist you with this.

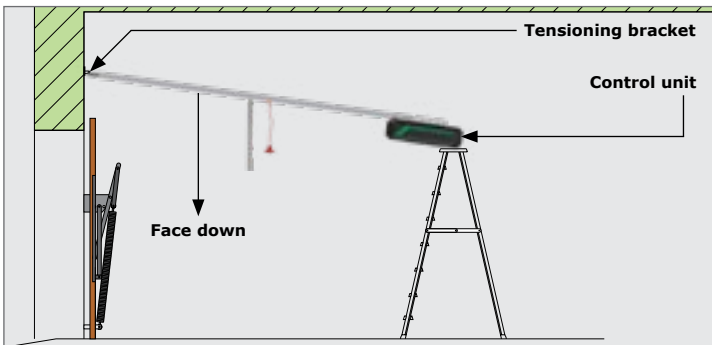

FIGURE 50



If you are on your own, use a ladder to support the control unit end of the **SD05 SMART+** while you are positioning it for the next step (Figure 50).

Align the holes on the side of the tensioning bracket with the holes of the header bracket.

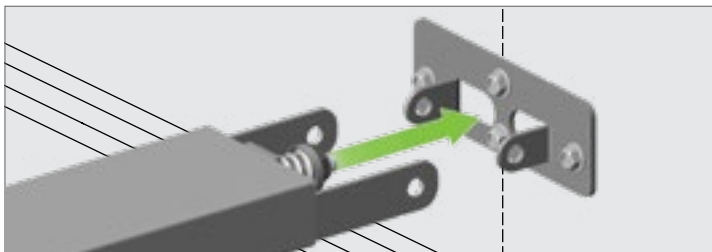

FIGURE 51

Locate the long clevis pin through the holes and secure it into position with a supplied E-Clip on the other end of the clevis pin.



Split Pins have also been supplied should they be preferred over the use of the circle pin clips.

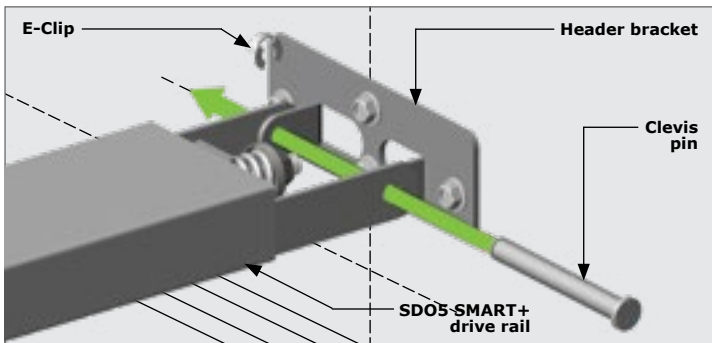

FIGURE 52

6.2.2.3. Mounting the **SDO5 SMART+** drive rail to the ceiling

Open the garage door, and rest the **SDO5 SMART+** on top of the open door.



If your ladder is high enough, we recommend resting it on top of the ladder.

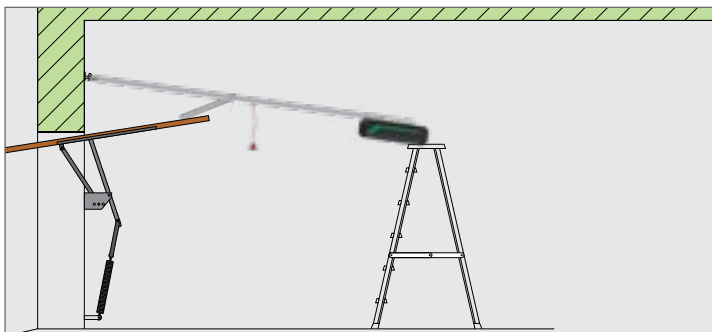

FIGURE 53

Find the centre line of the garage door, and mark it on the ceiling above the location of the **SDO5 SMART+** Head Unit.



You can use the **SDO5 SMART+** Drive Rail as a gauge to assist you if needed.

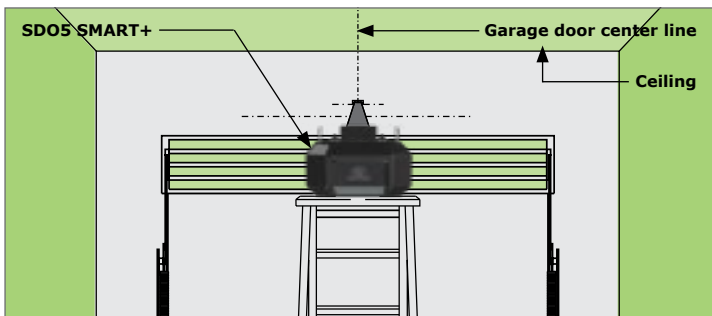

FIGURE 54

Lift the **SD05 SMART+** to a point where the control unit (Point B) is in line with the top of the open garage door (Point A).

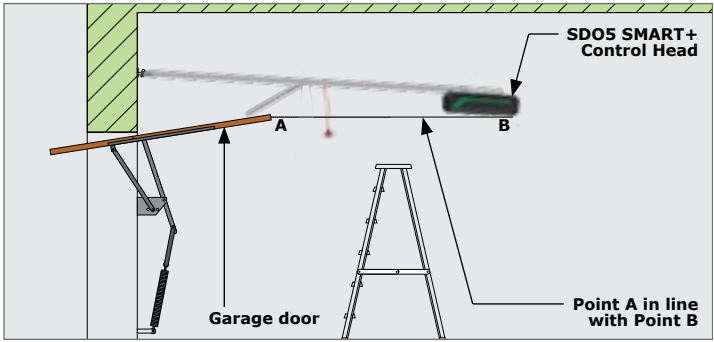

FIGURE 55

Place a spirit level perpendicular to the ceiling, aligning it with the center of one of the holes on the Metal Support Chassis at the top of the **SD05 SMART+** Head Unit. Make a mark on the ceiling, and repeat this for the other Metal Support Chassis on the other side of the Head Unit.



Ensure the Metal Support Chassis is positioned directly beneath a **strong** structural member in the ceiling. Adjust the spirit level so it aligns with a hole in the Metal Support Chassis that sits directly under this structural member.

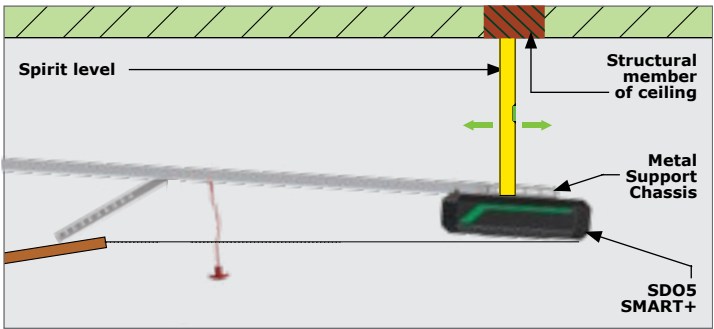

FIGURE 56

Draw a line on the ceiling joining these two marks, perpendicular to the garage door center line made earlier.

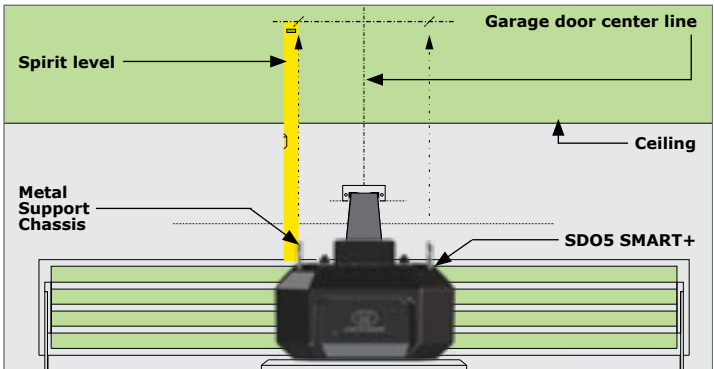

FIGURE 57

Measure and cut a 300mm length of punched angle iron with a pair of tin snips.



Snip off the four corners of the punched angle iron to add a degree of safety and neatness to the installation.

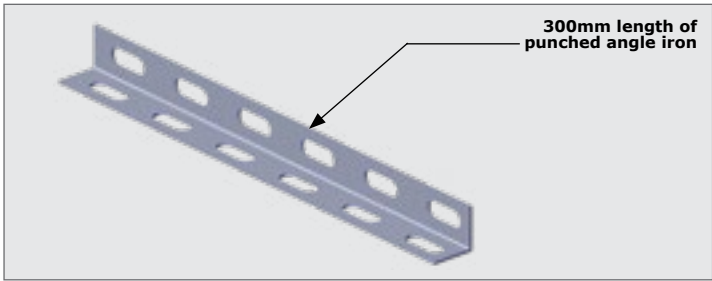

FIGURE 58

Align the punched angle iron centered onto the garage door center line, and the perpendicular line running along the center of the horizontal face holes. The horizontal face must face the back of the garage. Secure the punched angle iron to the ceiling with suitable screws (depending on the structural member of the ceiling).



Ensure that the punched angle iron is mounted to a strong structural member in the ceiling.

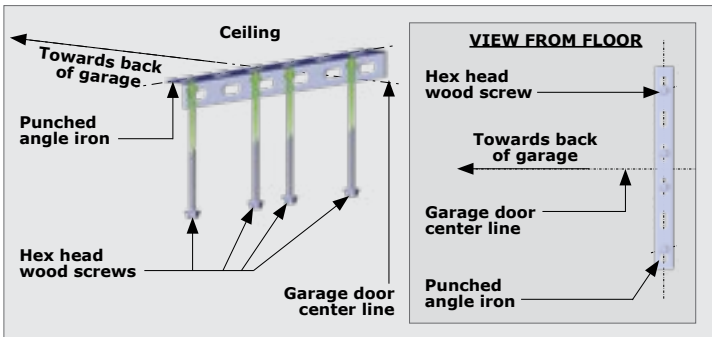

FIGURE 59

Position the **SDO5 SMART+** again, as shown in Figure 55, and measure the length needed from the ceiling to the Metal Support Chassis, marked as 'Value Xmm' in Figure 59.

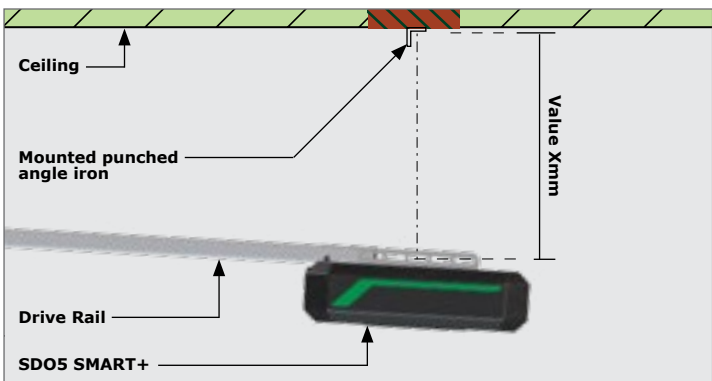

FIGURE 60

Using an angle grinder or hack saw, cut two lengths of punched angle iron to the measurement taken for 'Value Xmm'.



Snip off the corners of the punched angle iron to add a degree of safety and neatness to the installation.

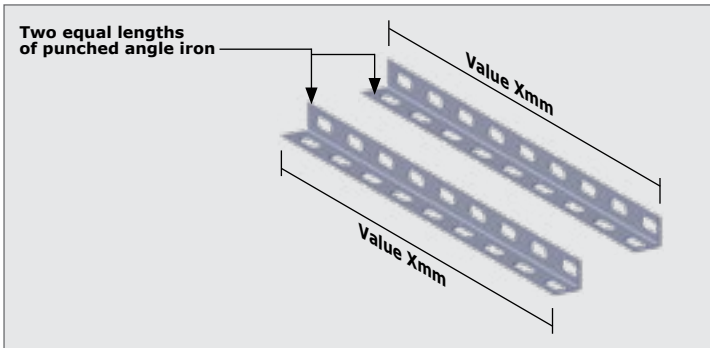

FIGURE 61

Locate the two lengths of punched angle iron into position as shown in Figure 61, and secure them in position with the two M8 Wizzlock Nuts, and two M8X20 Hexhead Bolts.

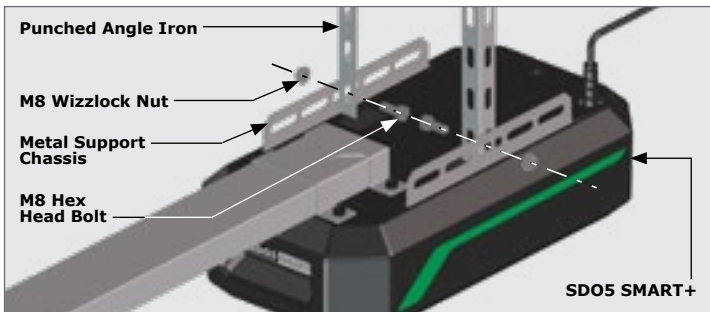

FIGURE 62

Align the holes of the Punched Angle Iron mounted to the ceiling, with the holes on the Metal Support Chassis. Secure them into position using two supplied M8 Hexhead bolts and Wizzlock Nuts with a 13mm socket. Ensure that the **SDO5 SMART+** control unit is in line with the top edge of the open garage door before tightening the bolts in their final position.

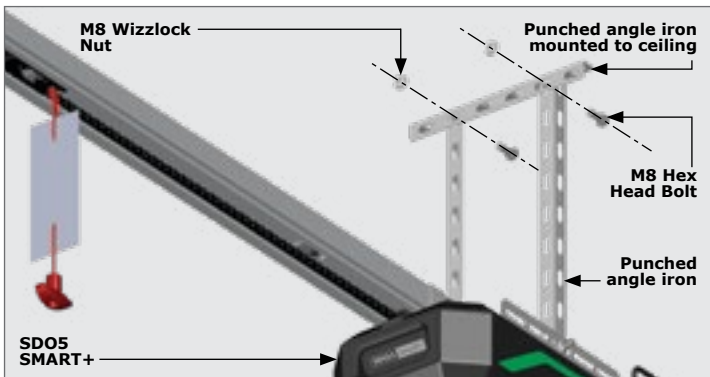

FIGURE 63

Correct and incorrect configurations for mounting the **SDO5 SMART+** to the ceiling.

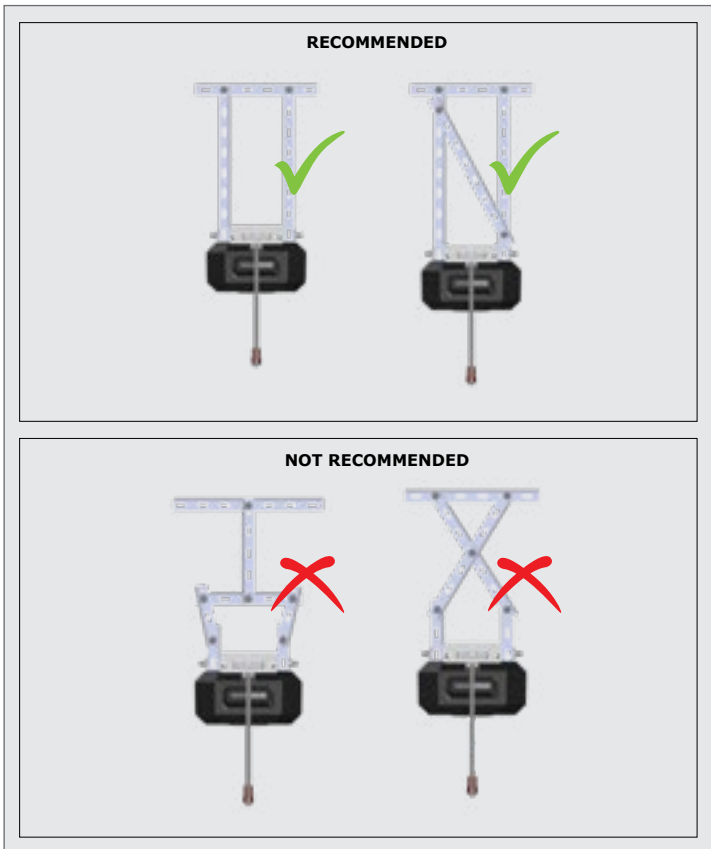

FIGURE 64. CORRECT AND INCORRECT MOUNTING CONFIGURATIONS

6.2.2.4. Mounting the Towing Bracket to the Garage Door

Close the garage door, and find its center line.

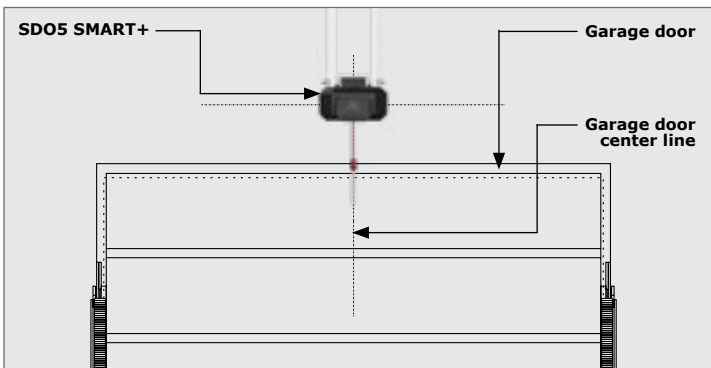

FIGURE 65

Center the towing bracket on the garage door center line and so that the top edge of the towing bracket is as close to the top edge of the garage door as possible.



Place a small spirit level on the top edge of the towing bracket, to ensure that it is level when drilling holes.

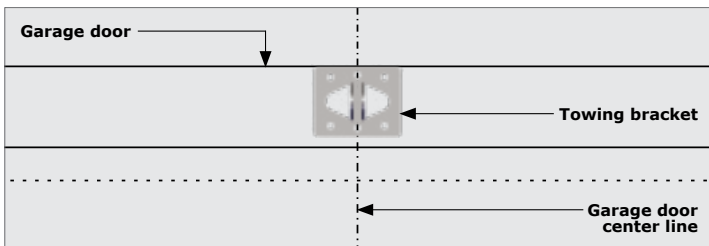

FIGURE 66

Secure the towing bracket into position using the three hexagonal head self-tapping screws supplied.

- If the garage door is heavier than average, more screws can be used to fix the bracket to the garage door.
- Ensure that the length of the screws do not exceed the depth of the garage door.
- The above method is for the purpose of wooden garage doors. Should you have a garage door that is not constructed from wood, such as a steel garage door, we recommend the use of high-quality Tek screws to secure the towing bracket to the garage door.

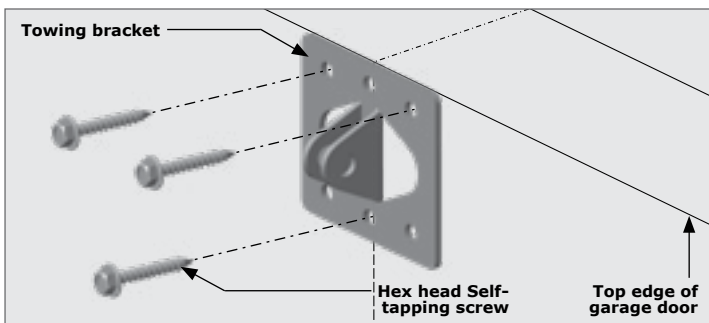

FIGURE 67

6.2.2.5. Fitting the bent towing arm to the towing bracket and straight towing arm

Slot the bent towing arm between the two protruding tabs of the towing bracket, and align the holes. Note the orientation of the bent towing arm.

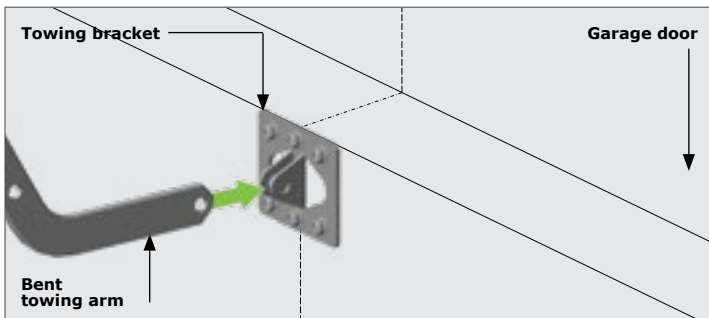

FIGURE 68

Locate the short clevis pin through the holes and secure it into position with a supplied E-Clip on the other end of the clevis pin.



Split Pins have also been supplied should they be preferred over the use of the circle pin clips.

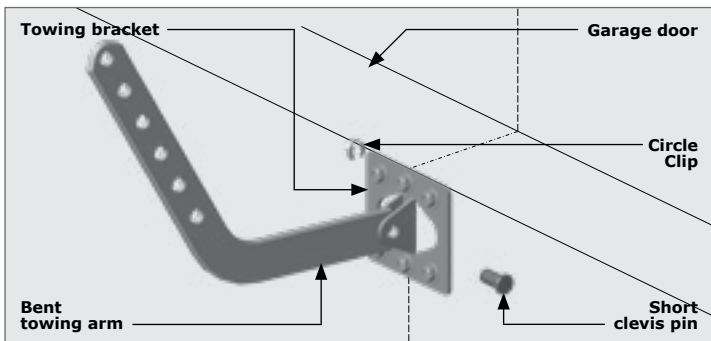

FIGURE 69

Slot the bent towing arm into the straight towing arm, and align the holes. If they do not align, move the carriage up or down the drive rail in order to align the holes of the bent and straight towing arms.



Ensure that the two towing arms overlap by at least two holes. This will ensure a strong join, and prevent the arm from swiveling whilst the motor is in operation.

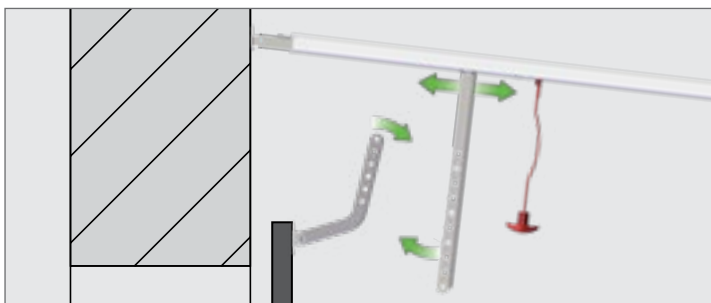

FIGURE 70



The two towing arms must be joined in such a way that they are just short of parallel to the garage door and the ceiling. Angle 'Z' should be $\pm 80^\circ$ when the garage door is in the closed position, as shown in Figure 70. This will put less strain on the motor on start-up and, furthermore, aid in preventing the garage door from being forced open by hand.

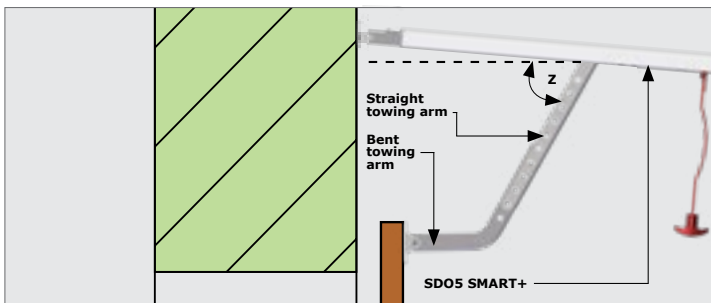

FIGURE 71

Once aligned, secure them into position using two supplied Wizzlock Nuts and M8x20 Hex Head Bolts: one set through the bottom hole of the straight towing arm, and the other through the top hole of the bent towing arm.

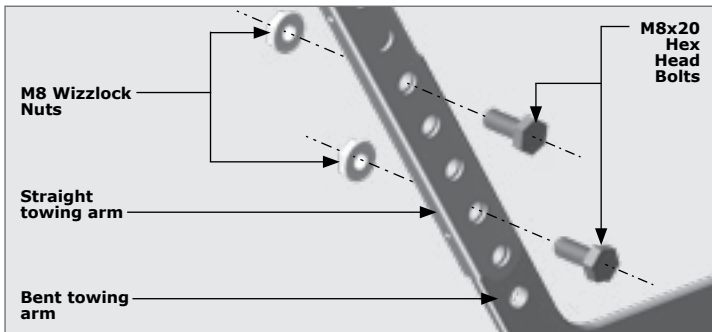

FIGURE 72



Please do not forget to affix the safety sticker and tag.

The **SDO5 SMART+** is now installed and ready for programming.

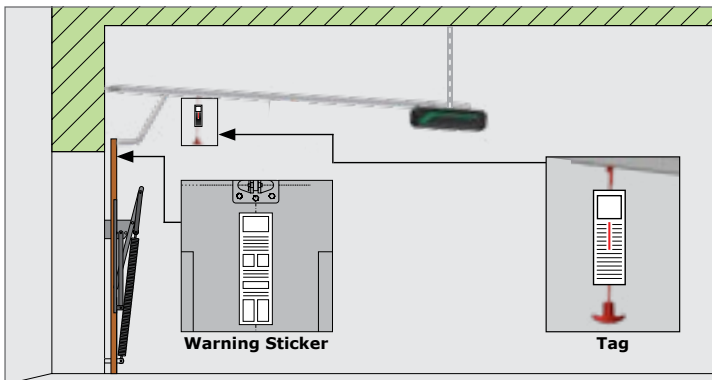

FIGURE 73

6.3. Retro-fit Installations

The **SDO5 SMART+** can be retro-fit into an existing SDO4/SDO4 SMART installation.

The Drive Rail Hanger Bracket needs to be removed from the existing Drive Rail.



It is **not recommended** to use the Drive Rail Hanger Bracket when replacing an existing SDO4/SDO4 SMART Head Unit with an **SDO5 SMART+** Head Unit. Due to the extra weight of the **SDO5 SMART+** Head Unit, this may distort or bend the drive rail.

1. Remove the 4x M6x12 screws and the two U-Brackets securing the SDO4/SDO4 SMART to the drive rail.





Ensure that the SDO4/SDO4 SMART Head Unit is well supported so it does not fall to the floor or get damaged while removing the U-Brackets from the Drive Rail and SDO4/SDO4 SMART Head Unit.

2. Unscrew the two M8 Nuts from the Gutter Bolts holding the Drive Rail Hanger Bracket to the Punched angle iron, suspended from the Ceiling.



Have a Ladder ready in position to support the existing Drive Rail as it is disassembled from its support structure.

3. Slide the Drive Rail Hanger Bracket off the Drive Rail along with the two gutter Bolts.
4. Follow the instructions in **Section 6.1.2.** - "General Assembly"  to secure the **SDO5 SMART+** Head unit to the existing Drive Rail.
5. Follow the instructions to secure the SDO5 SMART+ to the ceiling in **Section 6.2.1.3.** - "Mounting the SDO5 SMART+ Drive Rail to the ceiling"  - For Sectional Door Installations
or;
Section 6.2.2.3. - "Mounting the SDO5 SMART+ Drive Rail to the ceiling"  - For Tip up Door Installations

6.4. Engaging and Disengaging the Motor

Functionality

- TO DISENGAGE - pull down on the release handle until you hear a 'click'
 - TO ENGAGE - Pull the release handle back towards the control head until you hear a 'click', and move the carriage until it engages with the belt bullet (Figure 73)
- **Never attempt to open or close the garage door by pulling on the release handle. Doing so may result in SERIOUS PERSONAL INJURY and / or PROPERTY DAMAGE**
 - **Always disengage the SDO5 SMART+ with the garage door in the fully-closed position**
 - **If attempting to disengage the SDO5 SMART+ from any position other than with the garage door fully-closed, ensure that there are no persons and / or property near or directly under the path of the door**

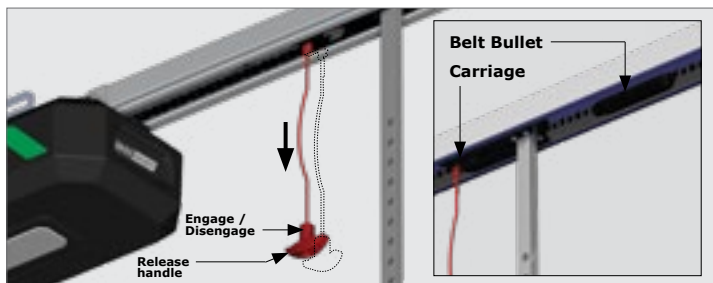



FIGURE 74

6.5. Emergency Lock Functionality

In the event of a system malfunction with the door in any position other than fully-closed, the **SDO5 SMART+** offers an emergency lock system that can be used to secure the door in the fully-closed position.

In order to close and lock the door in the fully-closed position, the user will need to disengage the operator using the manual release feature (see [Section 6.4.](#) ).



If attempting to disengage the SDO5 SMART+ from any position other than with the garage door fully-closed, ensure that there are no persons, pets and / or property near or directly under the path of the door.

1. Lower the door slightly by hand and re-engage the operator by pulling the manual release handle back towards the control head until you hear a 'click'.
2. Lower the door to the fully-closed position.
3. Test that the door has locked in place by attempting to lift it by hand.
4. Once the system malfunction has been rectified, the system can be returned to automatic operation by disengaging the operator using the manual release feature (see Section 6.3.).
5. Open the door slightly by hand and re-engage the operator by pulling the manual release handle back towards the control head until you hear a 'click'.
6. Raise the door slowly to the fully-open position until it engages with the bullet. A click will be heard as it engages.
7. The door is now ready for normal operation.

6.6. Positioning the Opening and Closing End-stops

The drive rail-mounted end-stops provide a one-to-one ratio between end-stop movement and garage door movement, thereby ensuring 100% accuracy and ease of adjustment. Fully-open and fully-closed positions of the garage door can be easily adjusted by moving the end-stops to the desired location in order to increase or decrease garage door travel.



Tighten the grub screws into position so that the flat-face of the screw butts firmly against the surface of the endstop. Note that the screws will indent the top of the rail.



If grub screws are not securely tightened, the end-stops will fail during setup.

6.6.1. Positioning the closing end-stop

- Ensure that the motor is disengaged
- Close the garage door fully
- Locate the closing end-stop within the drive rail - nearest to the front wall of the garage
- Position the end-stop 10mm away from the carriage, then tighten the two grub screws

6.6.2. Positioning the opening end-stop

- Ensure that the motor is disengaged
- Open the garage door fully
- Locate the opening end-stop within the drive rail - nearest to the back wall of the garage
- Position the end-stop 10mm away from the carriage, then tighten the two grub screws and then re-engage the motor

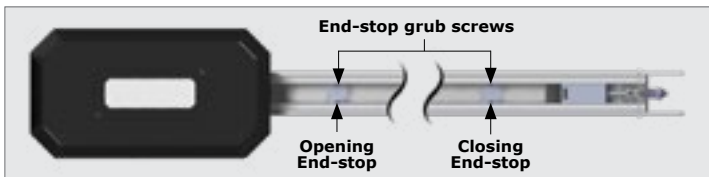

FIGURE 75



The closing and opening end-stops work on a one-to-one ratio with the garage door, meaning that, if the limit prong is moved by 10mm, then the garage door will also move by 10mm.

6.7. The Wireless Wall Switch

The Wireless Wall Switch provided with the **SD05 SMART+** kit (T12 Model only) provides ease of installation, obviating the need for running hard wires to the switch. It can be mounted in a convenient location such as adjacent to a side entry door into the garage. The four buttons provided on the Wireless Wall Switch are for independently operating from one Wireless Wall Switch, the two openers of a double garage door installation. The buttons can be used for activating the various functions provided by the system.

Each individual button of the Wireless Wall Switch has been marked with a number, from one to four, to help the user identify which function each button operates. The buttons can be learned in any configuration.



The Wireless Wall Switch must be mounted within sight of the garage door and a reasonable distance away from moving parts. It should be mounted at least 1500mm above the ground and the entrapment warning label provided, must be attached adjacent to the switch.

Mounting The Wall Switch

- The switch can be permanently screwed to the wall through the mounting holes provided or, alternatively, 'hooked' on the wall, providing the convenience of easy demount ability, through the 'hook' holes provided on the base cover
- To permanently mount the unit, open it, and place the back panel of the unit in the desired position on the wall

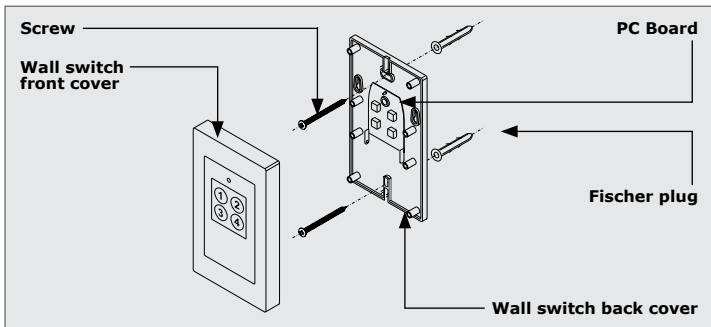

FIGURE 76



Take care not to damage the electronics when opening and handling the unit.

- Place a small spirit level on the top of the back panel to ensure that the unit will be level once mounted. Using a marking pen, mark the drill holes on the wall
- Drill two 6mm holes
- Locate two fischer plugs into the holes
- Align the back panel holes with the holes in the wall, and secure it into position using two screws
- Insert the battery, and replace the front cover
- The Wireless Wall Switch may be learned into the **SD05 SMART+**'s memory via the **MyCentsys Pro** mobile application under "Remotes" at the bottom of the screen

6.8. Safety Beams

- The Photon, or other four-wire safety beams may be connected to the **SDO5 SMART+**
- The installation of safety beams greatly enhances safety by constantly monitoring for persons or objects which may pass within the path of the moving garage door
- The **SDO5 SMART+** will safely reverse if the safety beams become momentarily or permanently interrupted during a closing cycle
- A pair of Photon SMART infrared beams can be added to the **SDO5 SMART+** installation without running any wires, making it an easy and cost-effective solution that offers maximum safety

6.8.1. Four-wire safety beams

6.8.1.1. Mounting

1. Mark the inside garage door framing so that the bottom edge of the beam sits 125mm off the floor.
2. Using a small angle bracket, fasten each beam to the wall so that they face each other across the garage door (Refer to installation instructions for further information).

6.8.1.2. Connection

Follow the safety beam instructions and connect to the output terminals. Use the normally-closed contacts of the beam to connect to input "I3" on the **SDO5 SMART+**. Refer to **Section 7** - "Electrical setup of accessories" .



The **SDO5 SMART+** provides a 24V DC output and normally-closed input for safety beams.



For aligning and testing the safety beams, please refer to the installation manual supplied with the respective safety beams used.

6.9. Connecting to a Power Supply

- Plug the **SDO5 SMART+** into a properly-earthed 220 to 240V AC power outlet
- Ensure that no excess power cord hangs below the control box

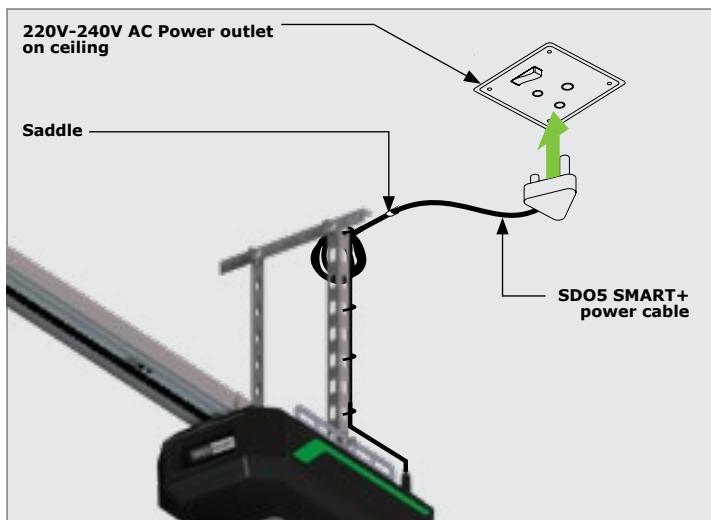

FIGURE 77

6.10. Battery Backup

The **SDO5 SMART+** is a mains-driven Garage Door Operator. A Battery Kit can be purchased from Centurion Systems (Pty) Ltd., or your Local Stockist to add the Battery Backup feature to the **SDO5 SMART+**.

6.10.1. Removing The SDO5 SMART+ Cover

Remove the Screw at the back of the **SDO5 SMART+** Head Unit.

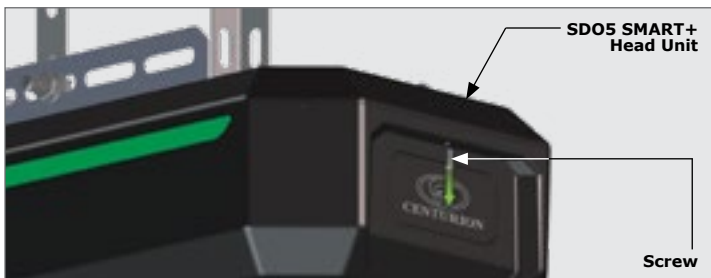

FIGURE 78

Whilst supporting the Bottom Cover of the **SDO5 SMART+** Head Unit from the back, pull and hinge the Bottom cover down.

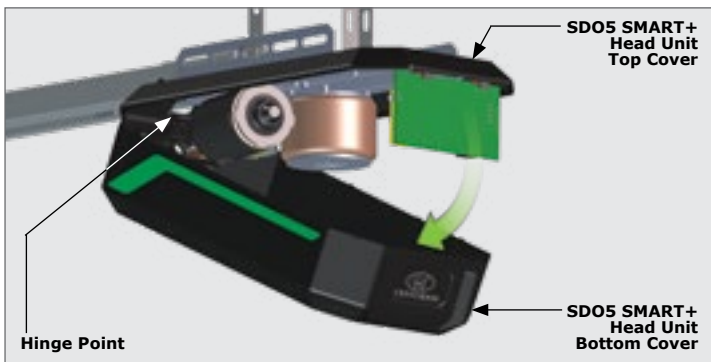

FIGURE 79



Take care not to pull too hard on the Bottom Cover to prevent damage or breaking the hinge in the front of the **SDO5 SMART+** Head unit.

Unclip the LED Harness from the LED on the bottom cover.

Lift the Bottom Cover up slightly in the front, and pull it toward the back of the **SDO5 SMART+** to release the U-bridge on the Bottom cover from the Tongue on the Top Cover (Hinge Mechanism) and free the Bottom Cover from the Top Cover.

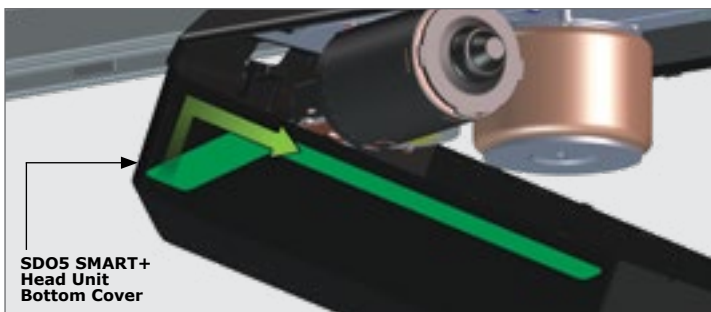

FIGURE 80

6.10.2. Installation of the Battery Kit

6.10.2.1. Preparing the Battery Kit for installation

The Battery Kit consists of a Battery Housing, 2x 12V 2.9AH Batteries, and a Battery Harness.

Insert the Batteries into the Battery Housing, and connect the Battery Leads of the Harness to the two Batteries, and route the Blue Clip End of the Harness through the Harness Outlet of the Battery Box.



Note the Orientation of the Batteries

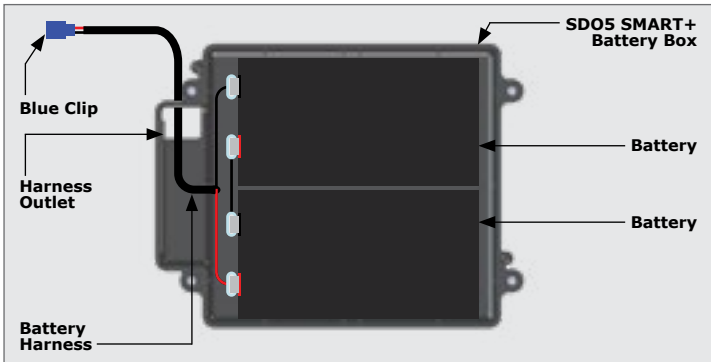

FIGURE 81

6.10.2.2. Securing the Battery Box into position

Screw the Battery Box into position directly onto the Metal Support Chassis, and Connect the Blue Clip of the Battery Harness into the Blue terminal on the side of the PC Board.



Note the Orientation of the Battery Box

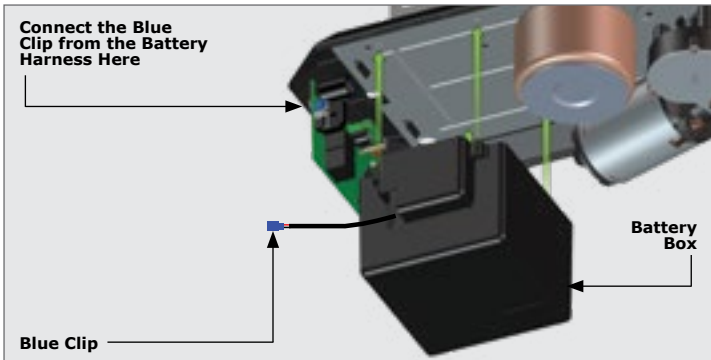

FIGURE 82

Return the Bottom Cover of the **SDO5 SMART+** By reversing the procedure shown in [Section 6.10.1.](#) - "Removing The **SDO5 SMART+** Cover" .

7. Electrical Setup of Accessories

- Two out (Power) and two in (Trigger and Safety beams) terminals are provided to support the connection of the most common external accessories
- The terminals can be accessed by removing the screw (Item 16) below the battery housing (Item 15), and hinging down the Control Head cover. Refer back to **Section 3** - "Product Identification" .
- The **SDO5 SMART+** supports the Photon SMART infrared gate safety beams, which are completely wireless safety ancillaries. Photon SMART beams can also be added to another set of safety beams (wired or wireless) to add further functionality, safety and peace of mind to the automated setup. The Photon SMART also delivers a much neater and unobtrusive safety system as there is no need for unsightly mechanical safety devices hanging from the ceiling of the garage

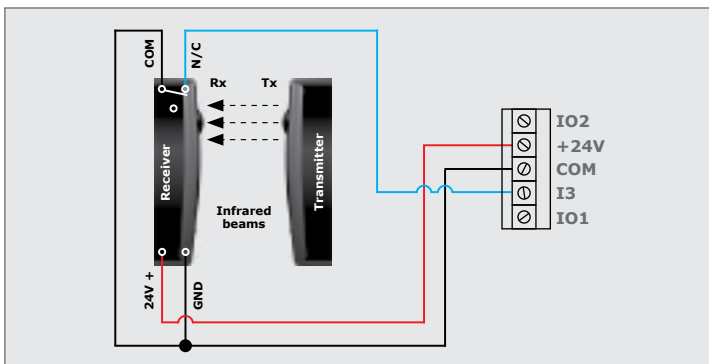

FIGURE 83. WIRING PHOTON SAFETY BEAMS TO THE SDO5 SMART+ (FOUR-WIRE)

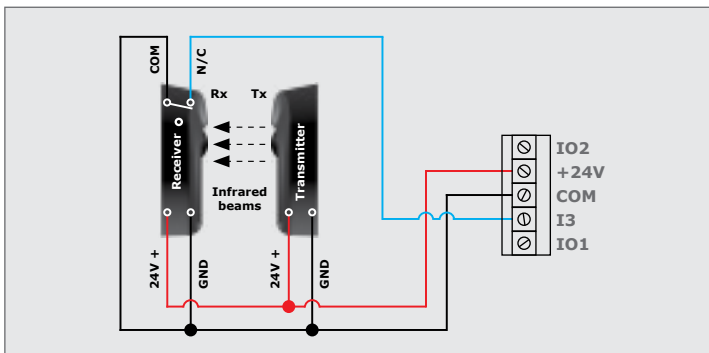

FIGURE 84. WIRING 15 SAFETY BEAMS TO THE SDO5 SMART+ (FOUR-WIRE)

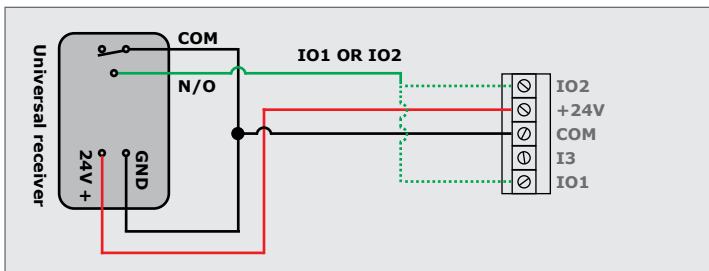

FIGURE 85. WIRING A UNIVERSAL RECEIVER TO THE SDO5 SMART+

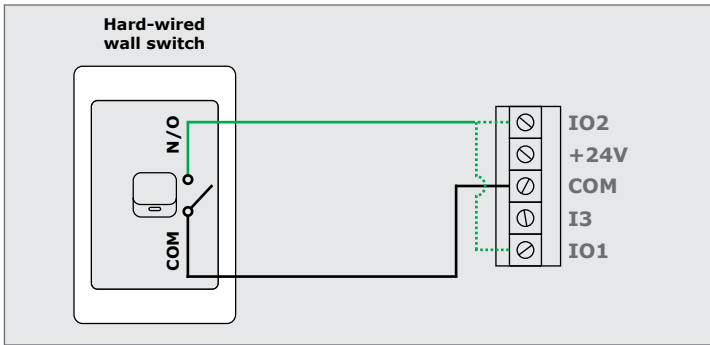
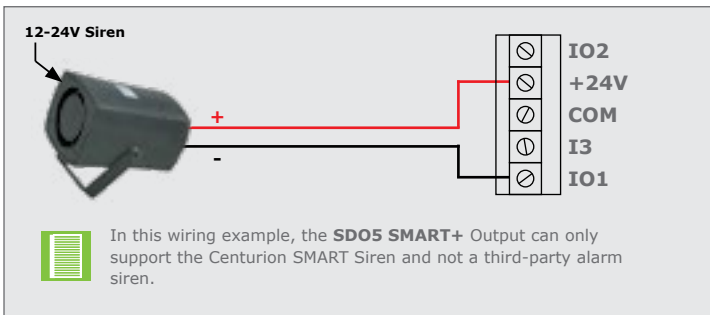

FIGURE 86. HARD-WIRING A WALL SWITCH TO THE SDO5 SMART+



- The trigger/TRG (green wire) in Figures 84, 85 and 86 can be either wired into IO1 or IO2, depending on the sites individual needs
- IO1 and IO2 can be configured using the MyCentsys Pro mobile application
- IO1 is configured as trigger/TRG by default



In this wiring example, the **SDO5 SMART+** Output can only support the Centurion SMART Siren and not a third-party alarm siren.

FIGURE 87. SMART SIREN CONNECTED TO SDO5 SMART+

8. Commissioning the System

1. Tap or scan the linked the QR Code or applicable App Store Icon in Figure 88.
2. Select the App Store applicable to the operating system being used, either Apple App Store, Android Google Play Store or the Huawei App Gallery.
3. Download and install the application(s).

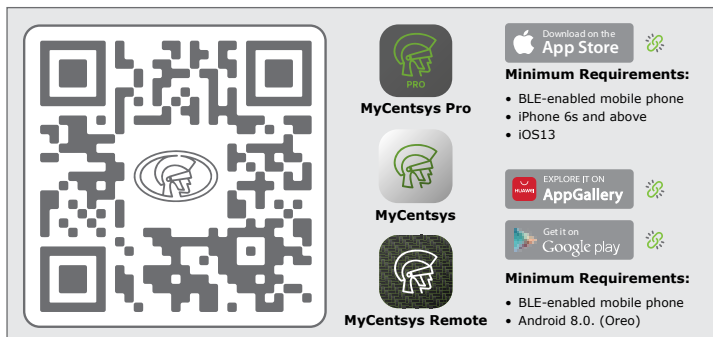

FIGURE 88

Alternatively, go directly to the app store of the operating system being used, and search for the apps. "MyCentsys Pro", "MyCentsys" and/or "MyCentsys Remote". Download and install the application onto the smartphone.

8.1. MyCentsys Pro Application

1. Once **MyCentsys Pro** has been installed, open the application.
2. From the list of operators, select the operator that applies to this installation.
3. Connect to the relevant operator.
4. Use the **MyCentsys Pro** app by following the prompts to configure the SMART/SMART+ operator.

8.2. MyCentsys Application

An intuitive configuration hub for all SMART/SMART+ devices.

MyCentsys puts the ultimate in configuration and flexibility at your fingertips.

1. Once installed, open the application.
2. From the list of operators, select the operator that applies to this installation.
3. Connect to the relevant operator.
4. Use the **MyCentsys** App by following the prompts to configure user settings on the SMART/SMART+ Operator:
 - Adding NOVA remotes, MyCentsys Remote Users and Admin Users.
 - Configuring the Wi-Fi settings (SMART+ Only).
 - Configuring ChronoGuard Settings.

8.3. MyCentsys Remote Application

An intuitive commanding hub for all SMART/SMART+ and ULTRA devices. **MyCentsys Remote** puts the ultimate in control and flexibility at your fingertips.

A fully customisable experience for your compatible access automation solutions.

1. Once installed, launch the application.
2. Register with the relevant details.
3. Select the "+ SMART" / "+ SMART+". (BLE Only)
 - If the Operator is connected to Wi-Fi (SMART+ Only) and the user is added as a **MyCentsys Remote** user, the operator will appear automatically on the list of operators in the **MyCentsys Remote** App.
4. From the list of operators, select the operator that applies to this installation.
5. Wait for the "Device Added" message after tapping on the selected operator.
6. Select the operator on the home screen to view all available triggers and device status.

9. PRODUCT ANCILLARIES

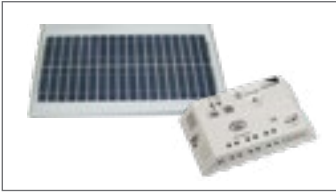

Solar Supply Solution

Alternative means of powering the system - consult your CENTURION dealer



Photon SMART Safety Beams

Fully-wireless infrared beams. Always recommended on any SMART/SMART+ automated installation



G-ULTRA

The ultimate GSM solution for monitoring and activating the operator via your mobile phone



G-SPEAK ULTRA

Answer your intercom from anywhere for maximum security and convenience - powered by 4G technology



12V-24V SMART Sirens

Both wired and wireless SMART Sirens designed to integrate with existing SMART and SMART+ gate and garage door operators



SMARTGUARD or SMARTGUARDair Keypad

Cost-effective and versatile wired and wireless keypad, allowing access to users with a customised code



Wireless Wall Switch

The four-button Wireless Wall Switch can operate the door, turn on the light and activate Holiday Lockout all without running any unsightly wires (Only included with T12 model)



Battery Backup Kit

Add the Battery Backup feature to the SDO5 SMART+ with this simple plug and play Battery Backup Kit (Includes 2x 2.9Ah Batteries)

10. Installation Handover Checklist

The final step in delivering a comprehensive service to the customer is to ensure a smooth handover of the site. Proper training for users is crucial for the safe and effective operation of the automated door system. Follow this guide to provide thorough training to users: Never assume the user knows how to safely operate an automated door.

10.1. Manual Release Mechanism

- Demonstrate how to operate the manual override mechanism. Emphasise the importance of engaging the manual override correctly.

10.2. Obstruction Detection and Safety Features:

- Demonstrate the functioning of obstruction detection and other safety features
- Demonstrate the functioning of the Safety Beams and any additional features such as PIRAC, Break-in Alarm, Ambush Alarm and Tamper Alarm (Optional, but recommended)
- Ensure that users are aware of the system's capability to respond to potential hazards; a useful tool for this purpose will be the notifications in the MyCentsys Remote App or the operator overview in the MyCentsys User App.

10.3. Operator Features and Benefits

- Provide a detailed overview of all features that have been configured, including the accessories
- Highlight the role of each feature configured in enhancing the functionality and safety of the system
- Assist the client in setting up their MyCentsys Remote App and explain how the MyCentsys Remote App performs actions and delivers notifications.
- Assist the client in setting up their MyCentsys User App and explain how to:
 - Add/Remove NOVA remotes
 - Add/Remove MyCentsys Remote Users
 - Add/Remove Admin Users (Ensure that the end-user is set as an Admin user on their operator)
 - Wi-Fi Configuration
- Explain how the NOVA remotes work and which button performs which function.
- Demonstrate how the courtesy light works.
- Highlight the functionality of the tamper alarm (optional, but recommended)

10.4. Safety Considerations:

- Stress the responsibility of users in passing on safety knowledge to others. Communicate the following safety considerations:
 - Do not activate the door unless the area of travel is clear
 - Avoid crossing the path of a moving door
 - Children should not operate or play with door controls
 - Maintain a safe distance from moving parts
 - Show the customer that all the necessary safety mechanisms have been installed on the physical door to ensure the safe operation of the physical door
 - Secure all easily-accessible door operator controls to prevent unauthorised use of the door

10.5. Door Operator Controls:

- Instruct users to secure door operator controls to prevent unauthorised use
- Emphasise the importance of controlling access to the door system

10.6. Maintenance and Checks

- Highlight the need for regular maintenance to ensure optimal system performance.

Run through parts that need to be maintained and checked regularly (i.e. door springs, door rail and rollers, door cable and pulleys, door hinges, etc.)

Operator health via the MyCentsys User App.

- Check if the obstruction detection system and safety devices for correct operation are in working order once a month
- Indicate that no additional lubricants are required on the rail.

10.7. Authorised Service:

- Communicate that all repair and service work must be performed by a qualified Centurion Systems professional
- Reinforce the importance of adhering to the guidelines for system integrity and warranty

10.8. Product Use and Liability:

- Emphasise that the product is designed for a specific use, and any other use may compromise the safety and warranty of the product
- Make users aware of their responsibility in using the product as documented

10.9. Centurion Systems (Pty) Ltd Disclaimer:

- Communicate Centurion Systems' disclaimer about product liability
- Centurion Systems (Pty) Ltd does not accept any liability caused by improper use of the product, or for use other than that for which the automated system was designed. Ensure that the customer has the User Guide and that you have completed the installation details in the back of the User Guide.
- Reinforce the importance of proper use to avoid any potential dangers
- Remember, a well-informed user is a key factor in maintaining the safety and longevity of the automated gate system. Thank you for your commitment to delivering excellence in service!

10.10. MyCentsys Pro, MyCentsys, and MyCentsys Remote

- The applications have been created with security in mind; if the user has security concerns, the following can be highlighted:
- Any new connection to the operator with the **MyCentsys Pro** and/or MyCentsys App needs to be authorised by pressing the courtesy light button on the operator. If a phone number has been added as an admin user, the user can connect without authorisation as the user is verified to connect to the operator. This will ensure that any would-be intruder can't access the programming to open the gate
- **MyCentsys Remote** users can only activate the operator if their number has been added as a **MyCentsys Remote** user. If the mobile number of the user has not been added, no connection can take place. This will ensure that any would-be intruder can't access the activations to open the gate

11. Warranty Information



You can register your product(s) online at www.centsys.com, which will assist you in keeping a record of your date of purchase or installation, serial numbers, etc.

All of our products are manufactured with extreme care, thoroughly inspected and tested.

The goods supplied by us shall be subject to the provisions of sections 55 to 57 of the Consumer Protection Act (68/2008) except where the provisions of the warranty contained in our product documentation are more favourable to the purchaser.

Subject to the warranty contained in our product documentation, if applicable, our products are warranted for a period of thirty-six months after delivery.

However, it is expressly noted that batteries carry a six month warranty due to the nature of these products being such that they are subject to possible misuse. Please note that warranties will be honoured on a carry-in basis; in other words, the product in question must be taken in to one of our branches, or to the authorised reseller that the product was purchased from, for assessment and, if necessary, repair.

For equipment not of our manufacture, the warranty as supplied by the original manufacturer will apply if such warranty is more favourable to the purchaser than the relevant provisions of the Consumer Protection Act (Act 68/2008 of South Africa), or any other applicable law

as so required in different countries in which the product was sold.

Such warranty is valid only once full payment has been received for such goods.

Australian customers:









Our goods come with guarantees that cannot be excluded under the Australian Consumer Law. You are entitled to a replacement or refund for a major failure and compensation for any other reasonably foreseeable loss or damage. You are also entitled to have the goods repaired or replaced if the goods fail to be of acceptable quality and the failure does not amount to a major failure

Any warranty may be voidable on any equipment which:

1. Has not been installed in accordance with the installation instructions provided.
2. Has been subject to misuse or which has been used for any purpose other than that designed for by the manufacturers.
3. Has damage caused as a result of handling during transit, atmospheric conditions (including lightning), corrosion of metal parts, insect infestation, power surges or other forces outside of the control of the manufacturer.
4. Has been repaired by any workshop and / or person NOT previously authorised by the manufacturer.
5. Has been repaired with components not previously tested, passed or authorised by Centurion Systems (Pty) Ltd, South Africa or one of its subsidiary companies.



Connect with us on:

-  [@CenturionSystemsRSA](#)
-  [@Centurion.Systems](#)
-  [@Centurion.Systems](#)
-  [@AskCenturion](#)
-  [@Centurion-Systems](#)
-  [@Centurion.Systems](#)
-  [@CenturionSystems](#)
-  [Centurion-Systems](#)

Subscribe to the newsletter: www.centsys.com/subscribe

WhatsApp - Technical Support

South Africa: +27 (0)83 650 4010
International: +27 (0)83 650 4244

Monday to Friday: from 08h00 to 16h30 (GMT+2)
Saturday: from 08h00 to 14h00 (GMT+2)

For more troubleshooting tips, visit our Knowledge Base at
CENTSYS KNOWLEDGE BASE
where you can find answers to common issues and detailed guides

E&OE Centurion Systems (Pty) Ltd reserves the right to change any product without prior notice
All product and brand names in this document that are accompanied by the ® symbol are registered trademarks
in South Africa and/or other countries, in favour of Centurion Systems (Pty) Ltd, South Africa.

The CENTURION and CENTSYS logos, all product and brand names in this document that are accompanied by the TM symbol
are trademarks of Centurion Systems (Pty) Ltd, in South Africa and other territories; all rights are reserved.
We invite you to contact us for further details.



Doc number: 1415.D.01.0001_02032026

www.centsys.com